

FMX

TOUGH DRIVE



TD/400 SERIES

AC Drive Instruction Manual

230V 1/3 Phase

IP20/NEMA 1
0.4–2.2kW / 0.5–3HP

230V 3 Phase

IP20/NEMA 1
0.4–30kW / 0.5–40HP

460V 3 Phase

IP20/NEMA 1
0.75–55kW / 1–75HP

Table of Contents

Chapter 1: Safety Precautions

1.1 Before supplying Power to the AC Drive	1-1
1.2 Wiring	1-1
1.3 Before Operation	1-2
1.4 Auto Tuning	1-2
1.5 Operation	1-2
1.6 Maintenance, Inspection, and Replacement	1-3
1.7 Disposal of the AC Drive	1-3
1.8 UL Standards	1-4

Chapter 2: Model Description

2.1 Nameplate Data	2-1
2.2 Wire Gauge, Tightening Torque, Terminal, Short Circuit, Circuit Breaker, and Fuse Ratings	2-2
2.3 AC Drive Specifications	2-3
2.4 General Specifications	2-6
2.5 AC Drive Dimensions	2-7

Chapter 3: Environment and Installation

3.1 Environment	3-1
3.2 Installation	3-2
3.3 External View	3-3
3.4 Warning Labels	3-5
3.5 Removing the Front Cover	3-5
3.6 Wiring Peripheral Power Devices	3-6
3.7 General Wiring Diagram	3-8
3.8 Control Circuit Terminals and Jumpers	3-9
3.9 Power Terminals	3-10
3.10 AC Drive Wiring	3-12
3.11 Input Power and Motor Cable Length	3-13
3.12 Cable Length vs. Carrier Frequency	3-13
3.13 Installing an AC Line Reactor	3-13
3.14 Power Input Wire Size, and NFB	3-14
3.15 Control Circuit Wiring	3-14
3.16 AC Drive derating based on Carrier Frequency	3-14
3.17 Braking resistors	3-15

Chapter 4: User Interface and Programming

4.1 LED Keypad	4-1
4.1.1 LED Keypad Display and Keys	4-1
4.1.2 Display Description	4-2
4.1.3 LED Status Description	4-4
4.1.4 Operation Control	4-5
4.1.5 Using the Keypad	4-6
4.2 Parameter Summary	4-8
4.2.1: Parameter default values and ranges depending on AC Drive model	4-40
4.3 Parameter Details	4-42
Group 00 Basic Parameters	4-42
Group 01 V/F Control Parameters	4-52
Group 02 IM Motor Parameters	4-61
Group 03 External Digital Input and Output Parameters	4-65
Group 04 Analog Signal Inputs / Analog Output	4-87

Group 05 Preset Frequency Parameters	4-91
Group 06 Automatic Program Operation	4-95
Group 07 Start/Stop Parameters	4-99
Group 08 Protection Parameters	4-111
Group 09 Communication Parameters	4-120
Group 10 PID Parameters	4-121
Group 11 Auxiliary Parameters	4-131
Group 12 Monitoring Parameters	4-139
Group 13 Maintenance Parameters	4-142
Group 14 PLC Parameters	4-145
Group 15 PLC Monitoring Parameters	4-147
Group 16 LCD Function Group	4-148
Group 17 Automatic Tuning Parameters	4-152
Group 18 Slip Compensation Parameters	4-156
Group 20 Speed Control Parameters	4-159
Group 21 Torque Limit Parameters	4-163
Group 22 PM Motor Parameters	4-164
Chapter 5: Built-in PLC Function	
5.1 Basic Command	5-1
5.2 Application Functions	5-3
5.2.1: Counter Function	5-3
5.2.2: Timer Function	5-5
5.2.3: Analog Comparator Function	5-8
5.2.4: Operation Control Function	5-9
5.2.5: Math Functions	5-10
Chapter 6: Communications	
6.1 Modbus Protocol	6-2
6.1.1 Network Connection	6-2
6.1.2 Date Format Frame for ASCII Mode	6-3
6.1.3 Data Frame for RTU Mode	6-3
6.1.4 CRC	6-4
6.1.5 Register and Data Format	6-5
6.1.6 Monitor Data (Read-only)	6-6
6.1.7 Read holding Register [03H]	6-8
6.1.8 Loop Back Test [08H]	6-9
6.1.9 Write Single Holding Register [06H]	6-10
6.1.10 Write Multiple Holding Register [10H]	6-11
6.1.11 Modbus Addressing	6-12
6.2 BACnet Protocol Descriptions	6-20
6.2.1 BACnet Object Properties	6-21
Chapter 7: Troubleshooting, Fault Diagnostics and Maintenance	
7.1 General	7-1
7.2 Fault Detection Function	7-1
7.3 General Troubleshooting	7-12
7.4 Troubleshooting Flowcharts	7-13
7.5 Routine and periodic inspection	7-19
7.6 Maintenance	7-21

1. Safety Precautions

1.1 Before supplying Power to the AC Drive

Warning:

MAIN CIRCUIT POWER SUPPLY TERMINALS MUST BE CORRECTLY WIRED



Single Phase Input: L1(L) and L3(N)
Three Phase Input: L1(L), L2, and L3(N)

MOTOR CONNECTION ONLY: T1, T2, T3
(input power connection here will destroy the AC Drive)

Warning:



- To avoid the front cover disengaging or other physical damage, do not carry the AC Drive by its cover. Support the unit by its heat sink when transporting. Improper handling can damage the AC Drive or injure personnel and should be avoided.
 - To avoid the risk of fire, do not install the AC Drive on or near flammable objects. Install on nonflammable objects such as metal surfaces.
 - If several AC Drives are placed inside the same control panel, provide adequate ventilation to maintain the temperature below 50°C/122°F to avoid overheating or fire.
 - When removing or installing the digital operator, turn off the power first and then follow the instructions in this manual to avoid operator error or loss of display caused by faulty connections.
-

1.2 Wiring

Warning:



- Always turn OFF the power supply before attempting AC Drive installation and wiring of the user terminals.
 - Installation and wiring must be performed by qualified personnel
 - Properly ground the AC Drive and motor-side ground. Improper grounding could result in serious injury or death from contacting the motor case.
 - Grounding impedance: 240V class - less than 100Ω, 480V class - less than 10Ω
 - Please check and test emergency stop circuits after wiring. (Installer is responsible for the correct wiring.)
 - Never touch any of the input or output power lines directly or allow any input or output power lines to come in contact with the AC Drive case.
 - Do not perform a dielectric voltage withstand test (megger) on the AC Drive. This will result in AC Drive damage to the semiconductor components.
 - Check all wiring to ensure all connections are correct after installation of AC Drive and any other devices. Failure to comply could result in serious injury, death, fire, or damage to the AC Drive.
-

Caution:



- Do not use an improper voltage source. Failure to comply could result in serious injury, death, fire, or damage to the AC Drive. Verify the rated voltage of the AC Drive matches the voltage of the incoming power supply before applying power.
 - Tighten all terminal screws to the specified tightening torque. Loose electrical connections could result in death or serious injury by fire due to overheating of electrical connections. (See Wire Gauge and Torque Specification section 2.2)
 - Never connect input power to the AC Drive output terminals T1, T2, T3.
 - Do not connect a contactor or switch in series with the AC Drive and the motor.
 - Do not connect a power factor correction capacitor or surge suppressor to the AC Drive output.
 - Ensure the interference generated by the AC Drive and motor does not affect peripheral devices.
 - Do not use unshielded cable for control wiring. Failure to comply may cause electrical interference resulting in poor system performance. Use shielded twisted-pair wires and ground the shield to the ground terminal of the AC Drive.
-

**Warning:**

This product is sold subject to IEC 61800-3. In a domestic environment this product may cause radio interference in which case the user may need to apply corrective measures.

1.3 Before Operation

Warning:

- Make sure the AC Drive capacity matches the parameter 13-00.
- Reduce the carrier frequency (parameter 11-01) if the cable from the AC Drive to the motor is greater than 80 ft (25m). A high-frequency current can be generated by stray capacitance between the cables and result in an overcurrent trip of the AC Drive, an increase in leakage current, or an inaccurate current readout.
- Do NOT remove any protective covers or attempt any wiring while input power is applied. Connect all power wiring and control wiring before applying input power. Always turn OFF the power supply before attempting AC Drive installation and terminal wiring.
- Do not operate switches with wet hands. Electric shock may result.
- Do not touch any terminals before the capacitors have fully discharged. Internal capacitors hold a charge after power supply has been removed. After disconnecting power, wait at least 10 minutes before touching any wiring, circuit boards, or components. Check DC voltage between terminals B1/P or (+) and (-) does not exceed 25V; otherwise, electric shock may result.



1.4 Auto-Tuning

Caution:

- Do not connect a load to the motor while performing a rotational auto-tune.
- Make sure the motor can freely run and there is sufficient space around the motor when performing a rotational auto-tune.



1.5 Operation

Warning:

- Do not connect or disconnect the motor during operation. This will cause the AC Drive to trip and may cause damage to the AC Drive.
- Operations may start suddenly if an alarm or fault is reset with a run command active. Confirm that no run command is active upon resetting the alarm or fault, otherwise accidents may occur.
- It provides an independent external hardware emergency switch which emergently shuts down the AC Drive output in the case of danger.
- If automatic restart after power recovery (parameter 07-00) is enabled, the AC Drive will start automatically after power is restored.
- Make sure it is safe to operate the AC Drive and motor before performing a rotational auto-tune.
- Do not touch AC Drive terminals when energized even if AC Drive has stopped, otherwise electric shock may result.
- Do not remove covers or touch circuit boards while the power is on. Failure to comply could result in death or serious injury.
- After the power is turned off, the cooling fan may continue to run for some time.

**Caution:**

- Do not touch heat-generating components such as heat sinks and braking resistors.
- Carefully check the performance of motor or machine before operating at high speed, otherwise injury may result.
- Note the parameter settings related to the braking unit when applicable.
- Do not use the AC Drive braking function for mechanical holding, otherwise injury may result.



1.6 Maintenance, Inspection, and Replacement

Warning:



- Internal capacitors hold a charge after power supply has been removed. After disconnecting power, wait at least 10 minutes before touching any wiring, circuit boards, or components. Check DC voltage between terminals B1/P or (+) and (-) does not exceed 25V; otherwise, electric shock may result.
 - Never touch high voltage terminals in the AC Drive.
 - Make sure power to the AC Drive is disconnected before disassembling the AC Drive.
 - Do not allow unqualified personnel to perform work on the AC Drive. Failure to comply could result in death or serious injury. Installation, maintenance, inspection, and servicing must be performed only by authorized personnel familiar with installation, adjustment, and maintenance of the AC Drive.
 - Do not perform work on the AC Drive while wearing loose clothing, jewelry, or lack of eye protection. Failure to comply could result in death or serious injury. Remove all metal objects such as watches and rings, secure loose clothing, and wear eye protection before beginning work on the AC Drive.
 - Observe proper electrostatic discharge (ESD) procedures when handling the AC Drive and circuit boards. Failure to comply may result in ESD damage to the AC Drive circuitry.
 - Do not modify the AC Drive circuitry. Failure to comply could result in damage to the AC Drive and will void warranty. FMX is not responsible for any modification of the product made by the user. This product must not be modified.
-

Caution:



- The AC Drive can be used in an environment with a temperature range from 14 -104°F (-10-40°C) and relative humidity of 95% non-condensing.
 - The AC Drive must be operated in a dust, gas, mist and moisture free environment.
-

1.7 Disposal of the AC Drive

Caution:



- Please dispose of this unit with care as an industrial waste and according to your required local regulations.
 - The capacitors of AC Drive main circuit and printed circuit board are considered as hazardous waste and must not be burned.
 - The plastic enclosure and parts of the AC Drive such as the top cover board will release harmful gases if burned.
-

1.8 UL Standards

❖ UL Standards

The UL/cUL mark applies to products in the United States and Canada and it means that UL has performed product testing and evaluation and determined that their stringent standards for product safety have been met. For a product to receive UL certification, all components inside that product must also receive UL certification.



❖ UL Standards Compliance

This AC Drive is tested in accordance with UL standard UL508C and complies with UL requirements. To ensure continued compliance when using this AC Drive in combination with other equipment, meet the following conditions:

■ Installation Area

Do not install the AC Drive to an area greater than pollution severity 2 (UL standard).

■ Motor Over Temperature Protection

Motor over temperature protection shall be provided in the end use application.

■ Field Wiring Terminals

All input and output field wiring terminals not located within the motor circuit shall be marked to indicate the proper connections that are to be made to each terminal and indicate that copper conductors rated 75°C are to be used.

■ AC Drive Short-Circuit Rating

This AC Drive has undergone the UL short-circuit test, which certifies that during a short circuit in the power supply the current flow will not rise above value. Please see electrical ratings for maximum voltage and table below for current.

- Circuit protection must be installed before AC drive. See section 2.3 of the user manual for the appropriate circuit breaker for your drive.
- Suitable for use on a circuit capable of delivering not more than (A) RMS symmetrical amperes for (HP) HP in 240 / 480 V class drives motor overload protection.

Horse Power (HP)	Current (A)	Voltage (V)
1 - 50	5,000	240 / 480
51 - 200	10,000	240 / 480

❖ AC Drive Motor Overload Protection

Set parameter 02-01 (motor rated current) to the appropriate value to enable motor overload protection. The internal motor overload protection is UL listed and in accordance with the NEC and CEC.

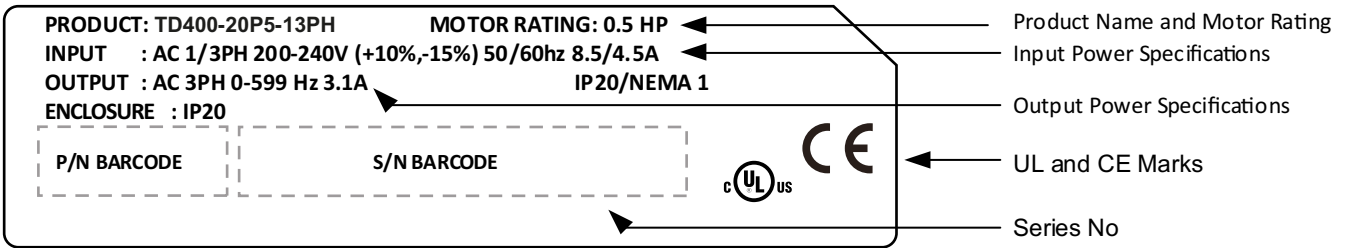
2. Model Description

2.1 Nameplate Data

Unpack the TD400 AC Drive and check the following:

- (1) The TD400 AC Drive start-up and installation manual (this document) is contained in the package.
- (2) The TD400 AC Drive has not been damaged during transportation; there should be no dents or missing parts.
- (3) The TD400 AC Drive is the type you ordered. You can check the type and specifications on the main nameplate.
- (4) Check that the input voltage range meets the input power requirements.
- (5) Ensure that the motor HP matches the motor rating of the AC Drive.

(1HP = 0.746 kW)



TD400 - 2010 - 1PH

TD400 AC Drive Series

Input Voltage Rating	
20:	200-240V
40:	380-480V

Motor Rating	
P5:	0.5 HP
01:	1 HP
02:	2 HP
03:	3 HP
05:	5 HP
08:	7.5 HP
10:	10 HP
15:	15 HP
20:	20 HP
30:	30 HP
40:	40 HP
50:	50 HP
60:	60 HP
75:	75 HP

Input	
1:	1Ph
13:	1Ph or 3Ph
3:	3Ph

2.2 Wire Gauge, Tightening Torque, Terminal, Short Circuit, Circuit Breaker, and Fuse Ratings

Frame size	AC Drive HP	AC Drive Voltage	Power Terminals				Control Terminals																			
			Maximum Wire Size	Tightening Torque			Wire Range	Tightening Torque																		
				kgf.cm	lbf.in	Nm		kgf.cm	lbf.in	Nm																
Frame 1	0.5–1	240	12 AWG 4mm ²	10.2	8.9	1	30–12 AWG 0.05–4 mm ²	4	3	0.4																
	1–2	480																								
Frame 2	2–5	240	8 AWG 10mm ²	18.4	15.9	1.8					30–12 AWG 0.05–4 mm ²	4	3	0.4												
	3–5	480																								
Frame 3	7.5–10	240	4 AWG 25mm ²	24.5	21.2	2.4									30–12 AWG 0.05–4 mm ²	4	3	0.4								
	7.5–15	480																								
Frame 4	15–20	240	4 AWG 25mm ²	24.5	21.2	2.4													30–12 AWG 0.05–4 mm ²	4	3	0.4				
	20–25	480																								
Frame 5	25	240	2 AWG 35mm ²	25.5	22.1	2.5																	30–12 AWG 0.05–4 mm ²	4	3	0.4
	30	480																								
Frame 6	30–40	240	3/0 AWG 95mm ²	81.6	70.8	8	30–12 AWG 0.05–4 mm ²	4	3	0.4																
	40–75	480																								

Notes:

- Wire size shown is based on maximum terminal size. Please consult the NEC or local codes for proper size to be used.
- The wire size assumes a maximum voltage drop of 2%. If this value is exceeded, a larger diameter wire size may be needed.
- Use only copper wires. Proper diameter wire should be based on ratings at 75°C.
- For safety reasons do not use under sized wiring.

2.3 AC Drive Specifications

240V Class: Single/Three phase

Model	TD400-20P5-13PH	TD400-2001-13PH	TD400-2002-13PH	TD400-2003-13PH
Horse power (HP)	0.5	1	2	3
Motor capacity (KW)	0.4	0.75	1.5	2.2
Rated output current (A)	3.1	4.5	7.5	10.5
Rated capacity (KVA)	1.2	1.7	2.9	4
Input voltage range(V)	Single/Three phase: 200–240V, 50/60HZ			
Allowable voltage fluctuation	-15%–+10%			
Output voltage range(V)	Three phase: 0~240V			
Input current (A)*	8.5/4.5	12/6.5	16/11	23.9/12.5
Circuit Breaker Current Rating	15A	20A	20A	30A
Fuse Rating	15A, 300VAC	30A, 300VAC	30A, 300VAC	30A, 300VAC
AC Drive net weight lbs(kg)	3.7 (1.7)	3.7 (1.7)	5.7 (2.6)	5.7 (2.6)
Allowable momentary power loss time(s)	2	2	2	2
Enclosure	IP20/NEMA1			
Braking Transistor	Built-in			

240V Class: Three phase

Model	TD400-2005-3PH	TD400-27P5-3PH	TD400-2010-3PH	TD400-2015-3PH
Horse power (HP)	5	7.5	10	15
Motor capacity (KW)	4	5.5	7.5	11
Rated output current (A)	17.5	26	35	48
Rated capacity (KVA)	6.7	9.9	13.3	20.6
Input voltage range(V)	Three phase: 200–240V,50/60HZ			
Allowable voltage fluctuation	-15%–+10%			
Output voltage range(V)	Three phase: 0–240V			
Input current (A)*	20.5	33	42	57
Circuit Breaker Current Rating	30A	50A	60A	100A
Fuse Rating	30A, 300VAC	60A, 300VAC	100A, 300VAC	200A, 300VAC
AC Drive net weight lbs(kg)	5.7 (2.6)	15.4 (7)	15.4 (7)	23.1 (10.5)
Allowable momentary power loss time(s)	2	2	2	2
Enclosure	IP20/NEMA1			
Braking Transistor	Built-in			

240V Class: Three phase

Model	TD400-2020-3PH	TD400-2025-3PH	TD400-2030-3PH	TD400-2040-3PH
Horse power (HP)	20	25	30	40
HD/ND Motor capacity (kW)	15	18.5/22	22/30	30/37
HD/ND Rated output current (A)	64	73/80	85/110	115/138
HD/ND Rated capacity (KVA)	27.4	27.8/30.1	32.4/41.9	43.8/52.6
Input voltage range(V)	Three phase: 200–240V,50/60HZ			
Allowable voltage fluctuation	-15%–+10%			
Output voltage range(V)	Three phase: 0–240V			
Input current (A)*	70	79.4/85.9	92.4/119.6	125/150
Circuit Breaker Current Rating	100A	100A	150A	175A
Fuse Rating	200A, 300VAC	200A, 300VAC	250A, 600VAC	300A, 600VAC
AC Drive net weight lbs(kg)	23.8 (10.8)	26.5 (12)	60.6 (27.5)	60.0 (27.5)
Allowable momentary power loss time(s)	2	2	2	2
Enclosure	IP20/NEMA1			
Braking Transistor	Built-in		Optional External	

480V Class: Three Phase

Model	TD400-4001-3PH	TD400-4002-3PH	TD400-4003-3PH	TD400-4005-3PH
Horse power (HP)	1	2	3	5
Suitable motor capacity (KW)	0.75	1.5	2.2	4
Rated output current (A)	2.5	3.8	5.3	9.2
Rated capacity (KVA)	1.7	2.9	4	6.7
Input voltage range(V)	Three phase: 380–480V,50/60HZ			
Allowable voltage fluctuation	-15%–+10%			
Output voltage range(V)	Three phase: 0~480V			
Input current (A)*	4.2	5.6	7.3	11.6
Circuit Breaker Current Rating	15A	15A	15A	15A
Fuse Rating	15A, 600VAC	15A, 600VAC	15A, 600VAC	15A, 600VAC
AC Drive net weight lbs(kg)	3.9 (1.8)	3.9 (1.8)	5.7 (2.6)	5.7 (2.6)
Allowable momentary power loss time(s)	2	2	2	2
Enclosure	IP20/NEMA1			
Braking Transistor	Built-in			

Model	TD400-47P5-3PH	TD400-4010-3PH	TD400-4015-3PH	TD400-4020-3PH
Horse power (HP)	7.5	10	15	20
Suitable motor capacity (KW)	5.5	7.5	11	15
Rated output current (A)	13	17.5	24	32
Rated capacity (KVA)	9.9	13.3	19.1	24
Input voltage range(V)	Three phase: 380–480V,50/60HZ			
Allowable voltage fluctuation	-15%–+10%			
Output voltage range(V)	Three phase: 0–480V			
Input current (A)*	17	23	31	38
Circuit Breaker Current Rating	20A	30A	50A	50A
Fuse Rating	20A, 600VAC	40A, 600VAC	70A, 600VAC	70A, 600VAC
AC Drive net weight lbs(kg)	15.4 (7)	15.4 (7)	15.4 (7)	24 (10.9)
Allowable momentary power loss time(s)	2	2	2	2
Enclosure	IP20/NEMA1			
Braking Transistor	Built-in			

Model	TD400-4025-3PH	TD400-4030-3PH	TD400-4040-3PH
Horse power (HP)	25	30	40
HD/ND Suitable motor capacity (kW)	18.5	22/30	30/37
HD/ND Rated output current (A)	40	45/58	60/73
HD/ND Rated capacity (KVA)	30.5	34.3/44.2	45.7/55.6
Input voltage range(V)	Three phase : 380–480V,50/60HZ		
Allowable voltage fluctuation	-15%–+10%		
Output voltage range(V)	Three phase : 0–480V		
Input current (A)*	48	48.9/63	65.2/78.3
Circuit Breaker Current Rating	75A	75A	100A
Fuse Rating	100A, 600VAC	125A, 600VAC	150A, 600VAC
AC Drive net weight lbs(kg)	24 (10.9)	26.4 (12)	60.6 (27.5)
Allowable momentary power loss time(s)	2	2	
Enclosure	IP20/NEMA1		
Braking Transistor	Built-in		Optional External

Model	TD400-4050-3PH	TD400-4060-3PH	TD400-4075-3PH
Horse power (HP)	50	60	75
HD/ND Suitable motor capacity (kW)	37/45	45/55	55/75
HD/ND Rated output current (A)	75/88	91/103	118/145
HD/ND Rated capacity (KVA)	57.2/67.1	69.3/78.5	89.9/111
Input voltage range(V)	Three phase : 380–480V,50/60HZ		
Allowable voltage fluctuation	-15%–+10%		
Output voltage range(V)	Three phase : 0–480V		
Input current (A)*	81.5/95.7	98.9/112	130/159
Circuit Breaker Current Rating	100A	150A	175A
Fuse Rating	200A, 600VAC	200A, 600VAC	300A, 600VAC
AC Drive net weight lbs(kg)	60.6 (27.5)	60.6 (27.5)	60.6 (27.5)
Allowable momentary power loss time(s)	2	2	2
Enclosure	IP20/NEMA1		
Braking Transistor	Optional External		

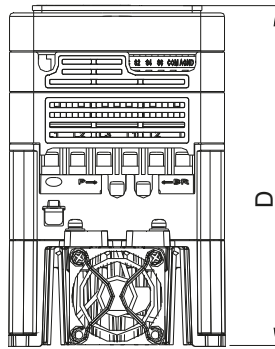
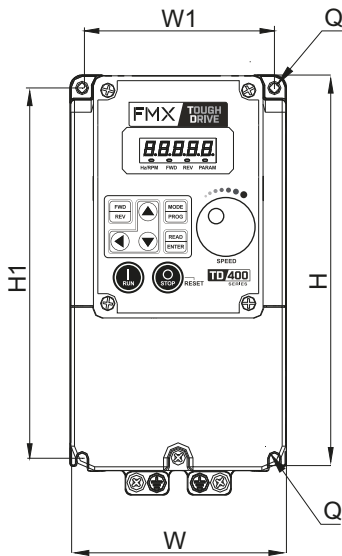
2.4 General Specifications

Control Mode		V/F, SLV, PMSLV control mode
Frequency	Output Frequency	0.01 - 599.00Hz
	Starting Torque	150% / 1Hz (SLV mode), 150% / 3Hz (V/F mode)
	Speed Control Range	1:50
	Setting resolution	Digital input: 0.01Hz
		Analog input:0.06Hz/60Hz
	Setting	Keypad: Set directly with ▲ ▼ keys or the VR on the keypad
External Input Terminals: AI1(0/2-10V), AI2(0/4-20mA) input Multifunction input up/down function(Group3)		
Setting frequency by communication method.		
Frequency limit	Lower and upper frequency limits, 3 skip frequency settings.	
Run	Operation set	Keypad run, stop button
		External terminals: Multi- operation-mode2 / 3 wire selection Jog operation
		Run signal by communication method.
Main Control Features	V / F curve setting	15 fixed curves and one customized curve
	Carrier frequency	1-16KHz (factory setting is 5kHz)
	Acceleration and deceleration control	2 Acceleration / deceleration time parameters. 4 S curve parameters.
	Multifunction input	Refer to description in parameter group 3
	Multifunction output	Refer to description in parameter group 3
	Multifunction analog output	Refer to description in parameter group 4
	Main features	Overload Detection, 16 preset speeds, Auto-run, Acc/Dec Switch (2 Stages), Main/Alt run Command select, Main/Alt Frequency Command, PID control, torque boost, V/F start Frequency, Fault reset.
Display	LED	Display: parameter / parameter value / frequency / line speed / DC voltage / output voltage / output current / PID feedback / input and output terminal status / Heat sink temperature / Program Version / Fault Log.
	LED Status Indicator	Run / Stop / Forward / Reverse, and etc.
Protective Functions	Overload Protection (OL1)	Electrical overload protection curve
	Overload Protection (OL2)	H.D mode: 150% rated current for 1 minute. N.D mode: 120% rated current for 1 minute
	Over voltage	240V Class: DC bus voltage higher than 410Vdc 480V Class: DC bus voltage higher than 820Vdc
	Under Voltage	240V Class: DC bus voltage lower than 190V 480V Class: DC bus voltage lower than 380V
	Momentary Power Loss Restart	AC Drive auto-restart after a momentary power loss.
	Stall Prevention	Stall prevention for Acceleration/ Deceleration/ Operation.
	Short-circuit output terminal	Electronic Circuit Protection
	Grounding Fault	Electronic Circuit Protection
	Other protection features	Heat Sink overheat protection, Temperature dependent carrier frequency, Fault output, Reverse prohibit, Prohibit for direct start after power up and error recovery, parameter lock, STO (Safety Torque Off)
Comm. Control		Built-in RS485 communication multi-drop communication. Built-in BACnet communication for building control. (Ex: Fire protection system, Air conditioning system, Monitoring system and Access control system)

Environment	Operating temperature	IP20/NEMA1 type: -10–50°C (without upper dust sticker) -10–40°C (with upper dust sticker)
	Storage temperature	-20–60°C
	Humidity	95% RH or less (no condensation) (Compliance with IEC 60068 - 2-78)
	Vibration	1G. (9.8m/s ²) for < 20Hz. 0.6G (5.88m/s ²) 20Hz–50Hz (Follow IEC60068-2-6 standard)
	Enclosure	IP20/NEMA1

2.5 AC Drive Dimensions

Frame 1

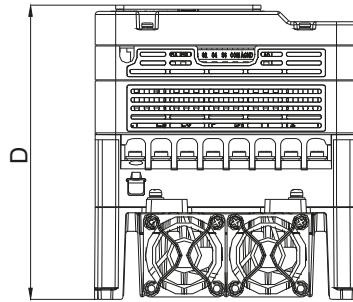
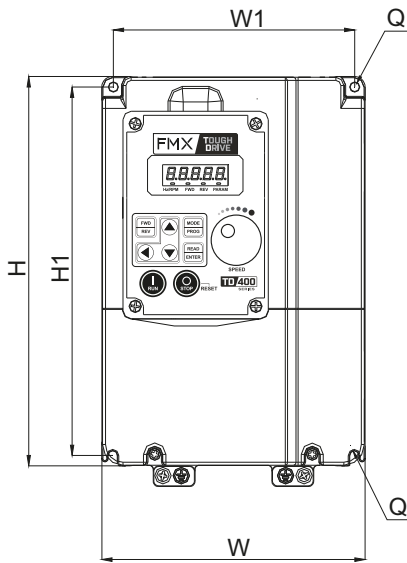


Models:

- TD400-20P5-13PH
- TD400-2001-13PH
- TD400-4001-3PH
- TD400-4002-3PH

Dimensions in mm (inch)						
W	W1	H	H1	D	Q	NEMA 1 Kit H
90.6 (3.57)	90.6 (3.57)	164 (6.46)	153 (6.02)	151.4 (5.96)	M4	186.2 (7.33)

Frame 2

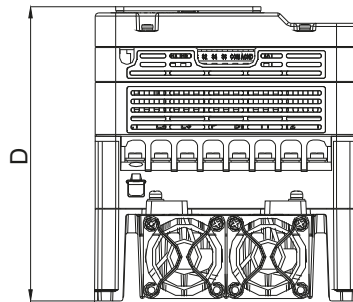
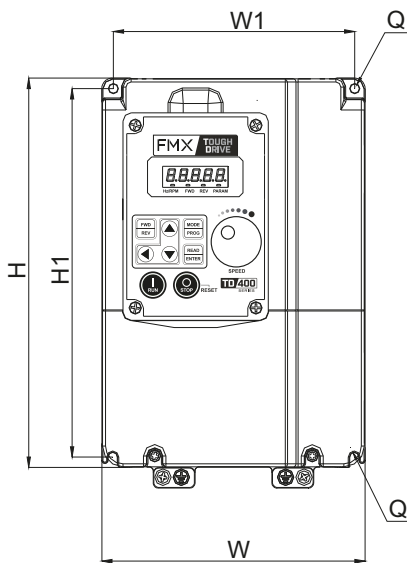


Models:

- TD400-2002-13PH
- TD400-2003-13PH
- TD400-2005-3PH
- TD400-4003-3PH
- TD400-4005-3PH

Dimensions in mm (inch)						
W	W1	H	H1	D	Q	NEMA 1 Kit H
128.7 (5.07)	118 (4.65)	187.6 (7.39)	177.6 (6.99)	152.4 (6)	M4	213.6 (8.41)

Frame 3

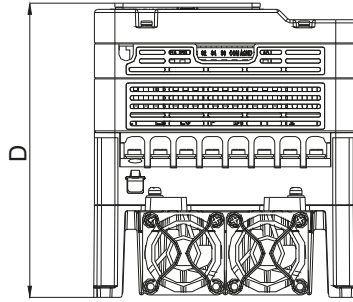
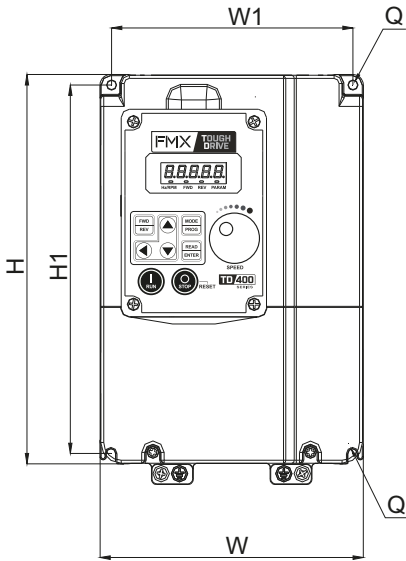


Models:

- TD400-27P5-3PH
- TD400-2010-3PH
- TD400-47P5-3PH
- TD400-4010-3PH
- TD400-4015-3PH

Dimensions in mm (inch)						
W	W1	H	H1	D	Q	NEMA 1 Kit H
186.9 (7.36)	175 (6.89)	260.9 (10.27)	249.8 (9.83)	202.6 (7.98)	M4	293.5 (11.56)

Frame 4

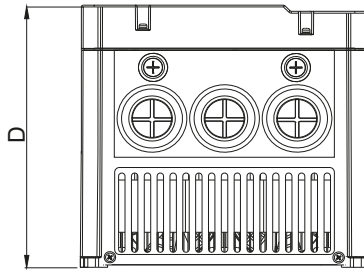
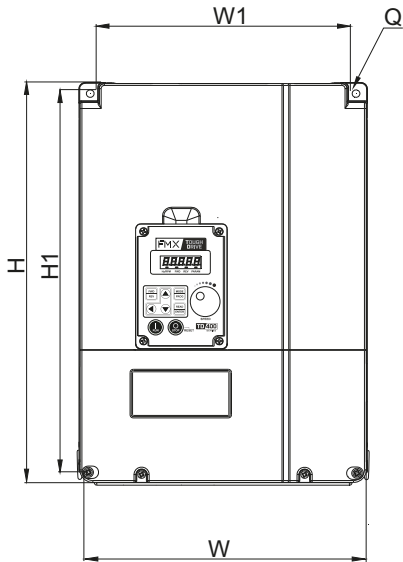


Models:

- TD400-2015-3PH
- TD400-2020-3PH
- TD400-4020-3PH
- TD400-4025-3PH

Dimensions in mm (inch)						
W	W1	H	H1	D	Q	NEMA 1 Kit H
224.6 (8.84)	207 (8.15)	321.6 (12.66)	303.5 (11.95)	206.1 (8.11)	M4	363.3 (14.3)

Frame 5

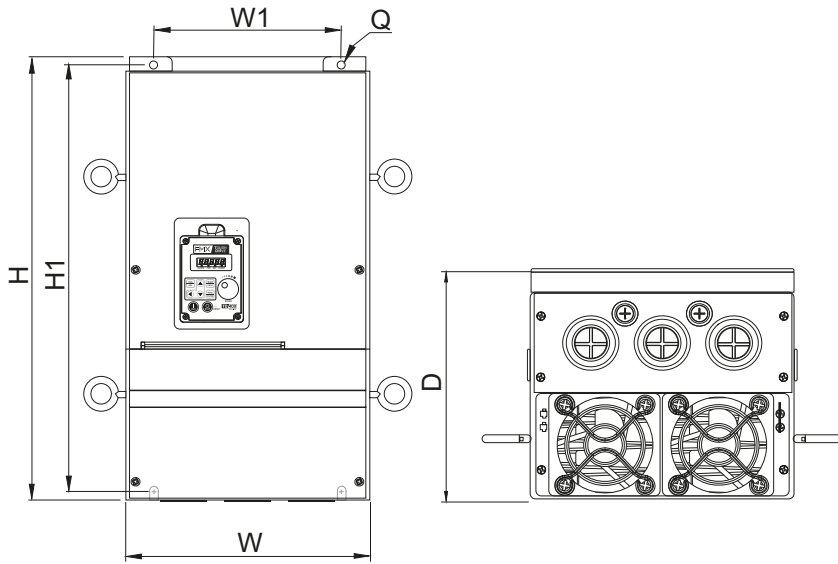


Models:

- TD400-2025-3PH
- TD400-4030-3PH

Dimensions in mm (inch)					
W	W1	H	H1	D	Q
265 (10.43)	245 (9.65)	360 (14.17)	340 (13.39)	238.2 (9.38)	M8

Frame 6



Models:

- TD400-2030-3PH
- TD400-2040-3PH
- TD400-4040-3PH
- TD400-4050-3PH
- TD400-4060-3PH
- TD400-4075-3PH

Dimensions in mm (inch)					
W	W1	H	H1	D	Q
286.5 (11.28)	220 (8.66)	525 (20.67)	505 (19.88)	269.8 (10.62)	M8

3. Environment and Installation

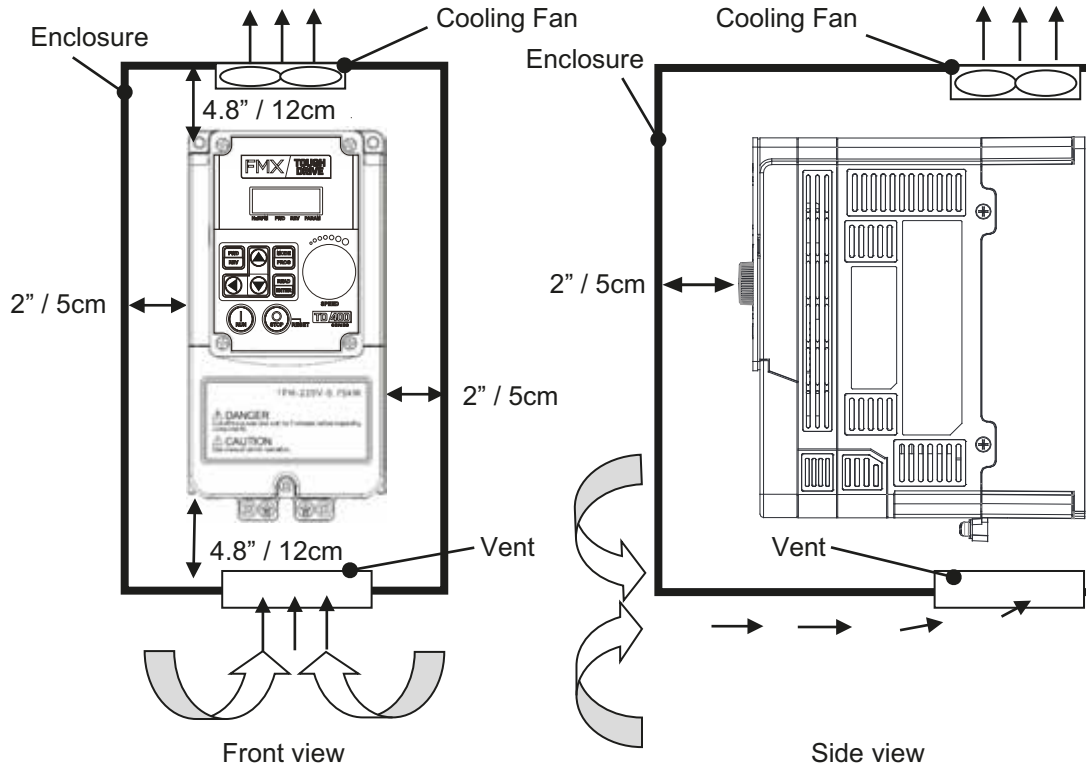
3.1 Environment

The environment will directly affect the proper operation and life span of the AC Drive. To ensure that the AC Drive will give maximum service life, please comply with the following environmental conditions:

Protection	
Protection Class:	IP20 / NEMA 1 (Depending on models)
Operating Temperature:	IP20 / NEMA 1 type: Inside: -10°C - +50°C (14-122 °F) Outside: -10°C - +40°C (14-104 °F) If several AC Drives are placed in the same control panel, provide additional cooling and ventilation to maintain ambient temperatures below 40°C (104 °F)
Storage Temperature:	-20°C - +60°C (-4 -140 °F)
Humidity:	95% non-condensing Relative humidity 5% to 95%, free of moisture. (Follow IEC60068-2-78 standard)
Altitude:	Full output current at < 1000m (3,281 ft.) Above 1000m (3,281 ft), it is required to derate drive output current by 1% for each additional 100m (328 ft) to a maximum of 2000m (6562 ft).
Installation Site:	Avoid exposure to rain or moisture.
	Avoid direct sunlight.
	Avoid oil mist and salinity.
	Avoid corrosive liquid and gas.
	Avoid dust, lint fibers, and small metal filings.
	Keep away from radioactive and flammable materials.
	Avoid electromagnetic interference (soldering machines, power machines).
	Avoid vibration (stamping, punching machines etc.).
Add a vibration-proof pad if the situation cannot be avoided.	
Shock:	Maximum acceleration: 1G (9.8m/s ²), for <20Hz Maximum acceleration: 0.6G (5.88m/s ²), for 20 - 50Hz (IEC60068-2-6 standard)

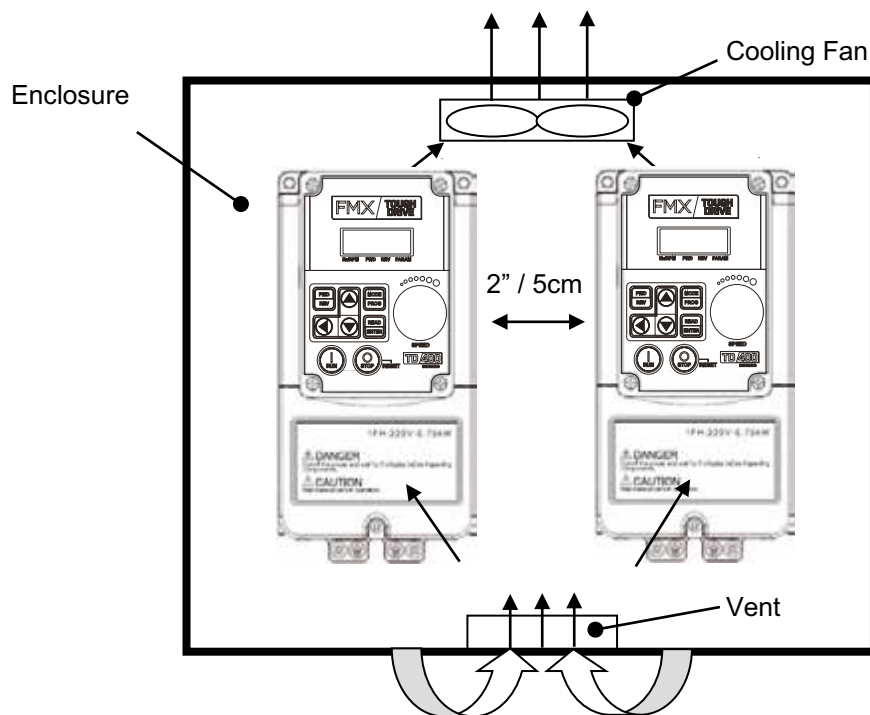
3.2 Installation

Provide sufficient air circulation space for cooling as shown in examples below. Install the AC Drive on surfaces that provide good heat dissipation.



Side by Side Installation

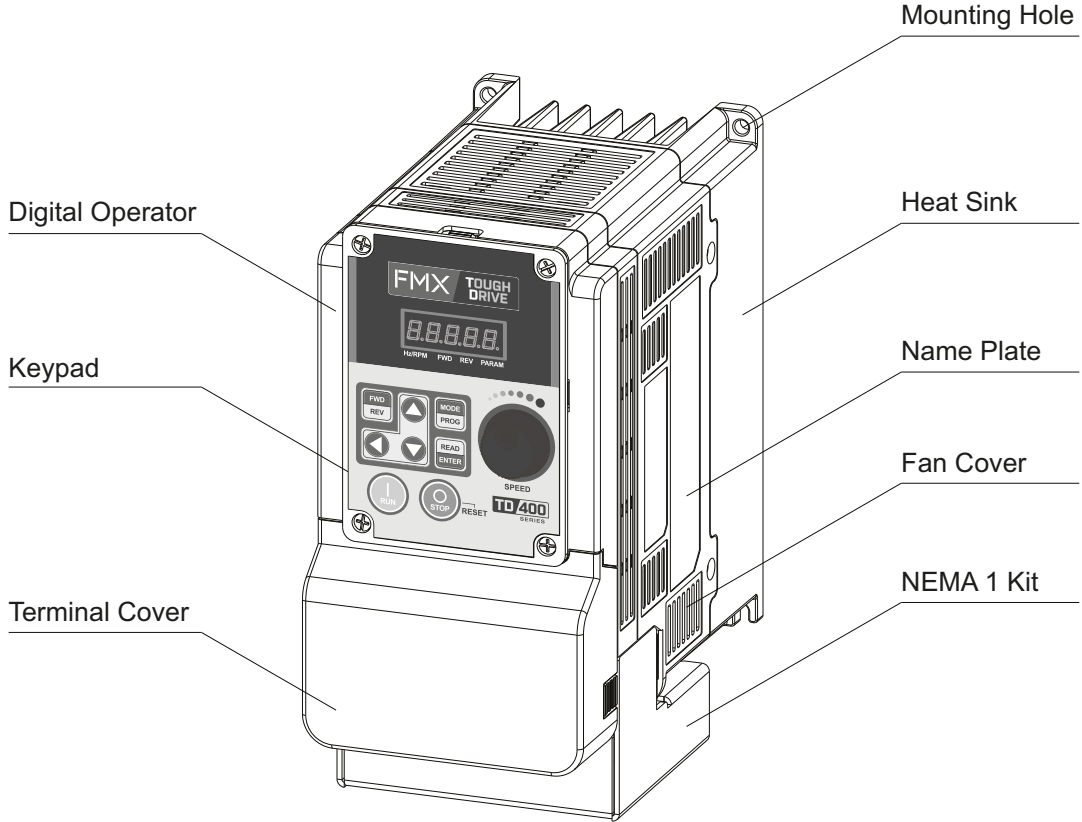
Provide the necessary physical space and cooling based on the ambient temperature and the heat loss in the panel.



3.3 External View

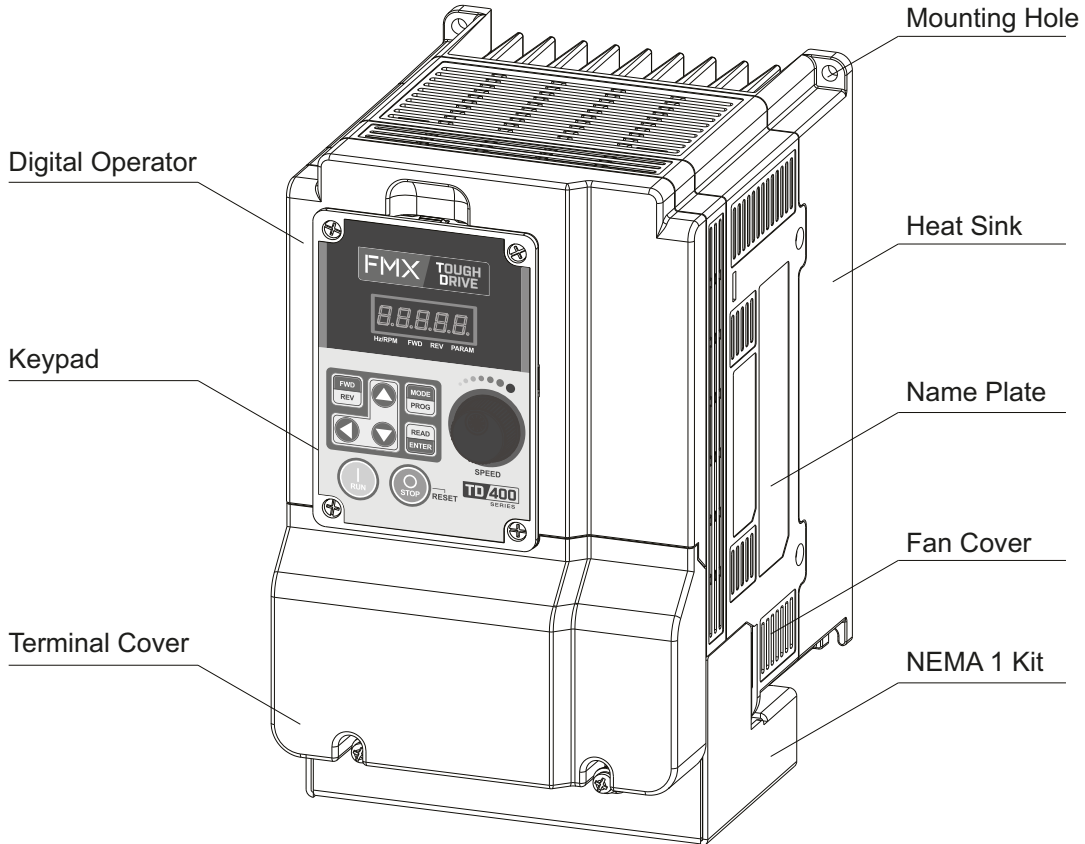
Frame 1:

240V 0.5HP–1HP (Single/Three Phase) / 480V 1HP–2HP / 240V 2HP (Three Phase)

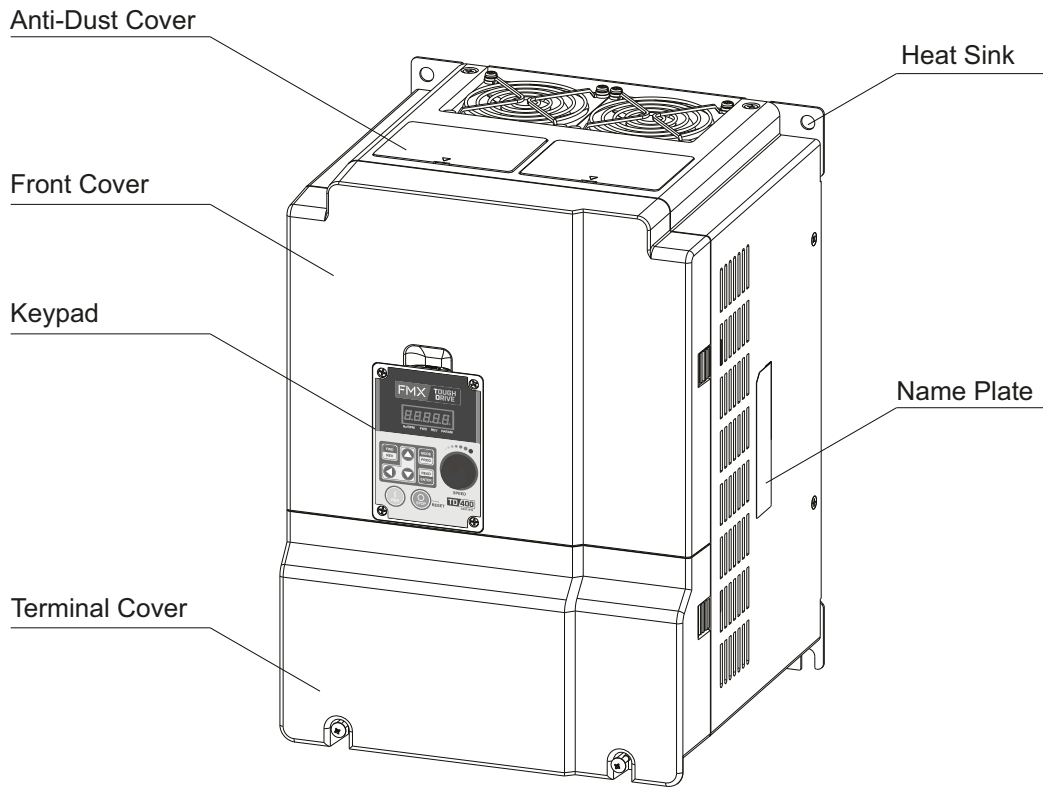


Frames 2–4:

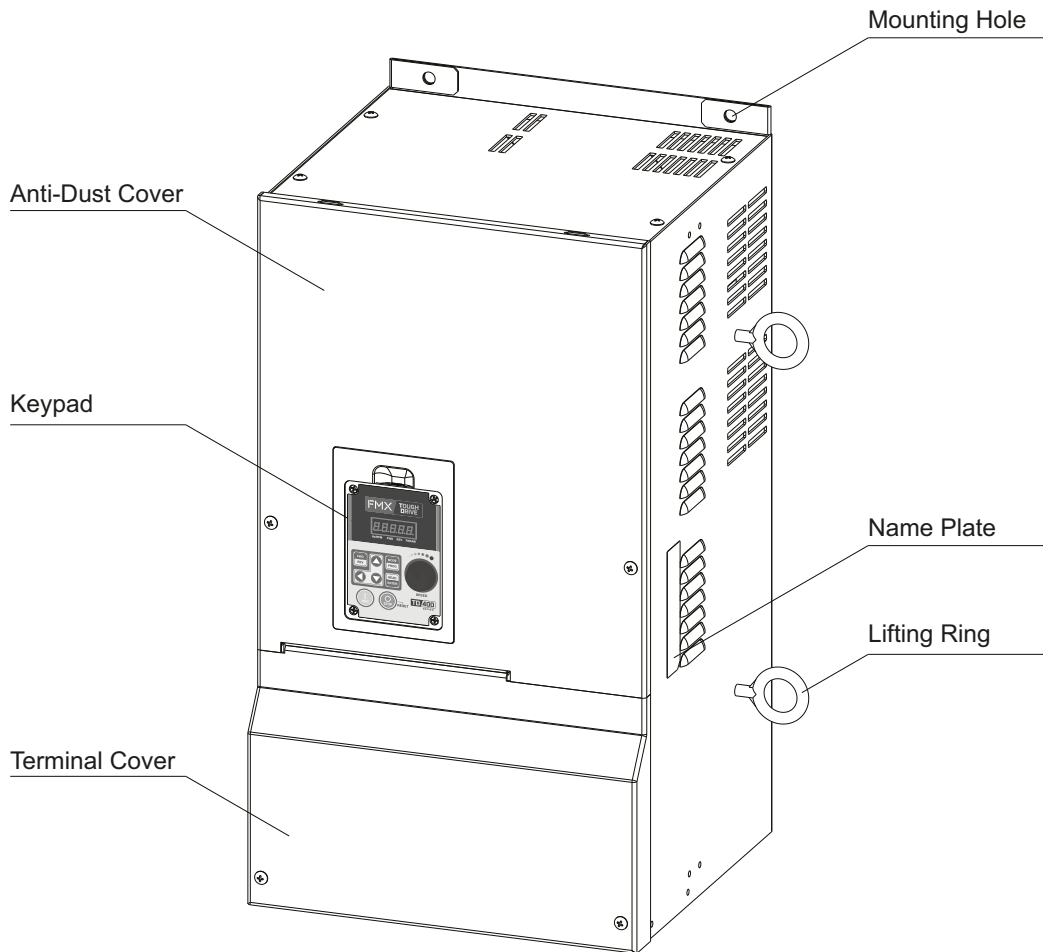
240V 2-3HP (Single/Three phase) / 240V 3HP–20HP / 480V 3HP–25HP



Frame 5:
240V 25HP / 480V 30HP



Frame 6:
240V 30HP-40HP / 480V 40HP-75HP



3.4 Warning Labels



Important:

Warning information located on the front cover must be read upon installation of the AC Drive.

240V 0.5HP–20HP / 480V 1HP–25HP

 **WARNING / AVERTISSEMENT**
Risk of electrical shock. Shut off main power and wait for 5 minutes before servicing.
 **Risque de choc électrique. Coupez l'alimentation principale et attendez 5 minutes avant l'entretien.**
 Hot surface. Risk of burn. / Surface chaude. Risque de brûlure.
 **CAUTION / ATTENTION**
See manual before operation. / Consultez le manuel avant l'opération.

240V 25HP–40HP / 480V 30HP–75HP

 **WARNING / AVERTISSEMENT**
Risk of electrical shock. Shut off main power and wait for 15 minutes before servicing.
 **Risque de choc électrique. Coupez l'alimentation principale et attendez 15 minutes avant l'entretien.**
 **CAUTION / ATTENTION**
See manual before operation. / Consultez le manuel avant l'opération.

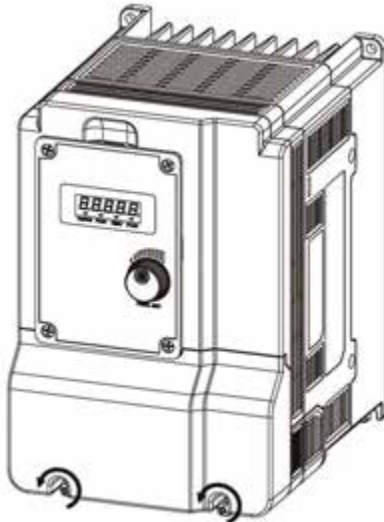
3.5 Removing the Front Cover



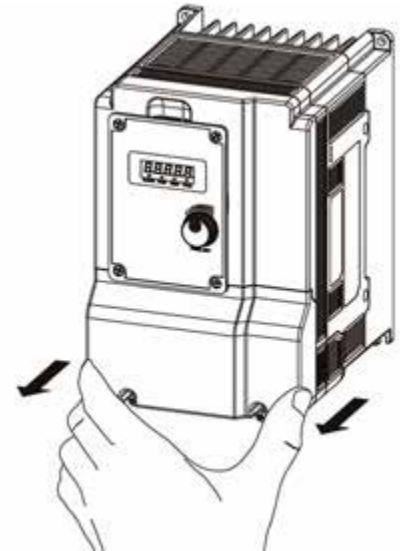
Before making any wiring connections to the AC Drive the front cover needs to be removed.

Step 1:
Unscrew cover

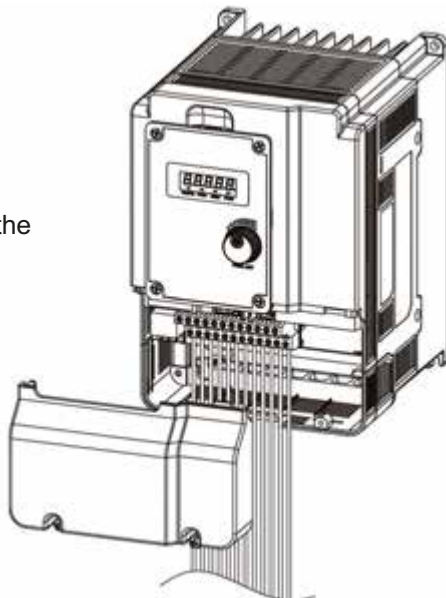
Note:
0.5HP–1HP 240V,
1HP–2HP 480V models
do not use screws.



Step 2:
Remove the terminal
cover



Step 3:
Wire and re-install the
cover



Step 4:
Tighten screws



3.6 Wiring Peripheral Power Devices



- After power is shut off to the AC Drive the capacitors will slowly discharge. Do NOT touch any of the AC Drive circuitry or replace any components until waiting at least 10 minutes.
 - Do NOT wire or connect/disconnect internal connectors of the AC Drive when the AC Drive is powered up or within 10 minutes of powering off.
 - Do NOT connect AC Drive output U, V and W to the supply power. This will result in damage to the AC Drive.
 - The AC Drive must be properly grounded. Use ground terminal to connect an earth ground and comply with local standards.
 - Do NOT perform a dielectric voltage withstand test (Megger) on the AC Drive this will result in AC Drive damage to the semiconductor components.
 - Do NOT touch any of the components on the AC Drive control board to prevent damage to the AC Drive by static electricity.
-

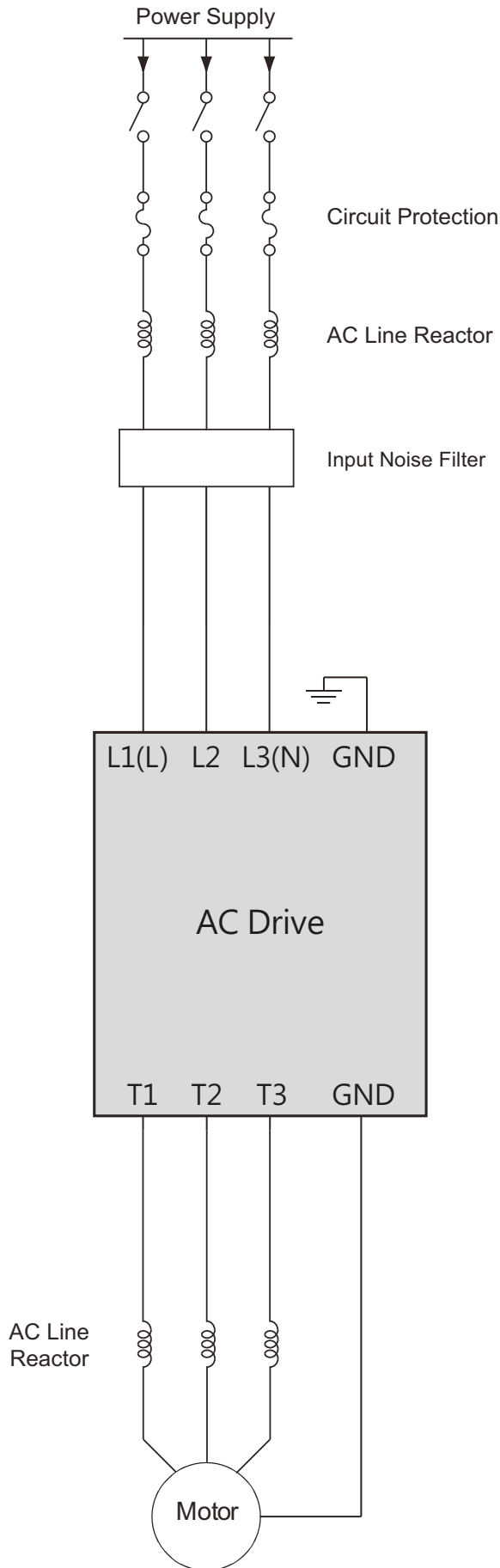
- Refer to the recommended wire size table for the appropriate wire to use. The voltage between the power supply and the input of the AC Drive may not exceed 2%.



Phase-to-phase voltage drop (V) = 3 × resistance of wire (Ω/km) × length of line (m) × current × 10⁻³.
(km=3280 x feet) / (m=3.28 x feet)

- Reduce the carrier frequency (parameter 11-01) if the cable from the AC Drive to the motor is greater than 25m (82ft). A high-frequency current can be generated by stray capacitance between the cables and result in an overcurrent trip of the AC Drive, an increase in leakage current, or an inaccurate current readout.
 - To protect peripheral equipment, install circuit protection on the input side of the AC Drive.
-

3.6.1 Typical AC Drive System



Power supply:

- Ensure correct voltage is applied to avoid damage to the AC Drive.

Circuit Protection:

- A molded-case circuit breaker or fused disconnect that conforms to the rated voltage and current of the AC Drive must be installed between the power supply and the AC Drive .
 - Do not use the circuit breaker as the run/stop switch for the AC Drive.
- Install a ground fault breaker to prevent problems caused by current leakage and to protect personnel. Select current range up to 200mA and action time up to 0.1 seconds to prevent high frequency failure.

AC line reactor (input):

- When AC Drives are supplied by a high capacity power source (> 600KVA), an optional AC line reactor can be connected to improve the power factor and protect the AC Drive from transient voltages.

Input Noise filter:

- An optional noise filter can be installed when there are inductive loads affecting the AC Drive.

AC Drive:

- Output terminals T1, T2, and T3 are connected to U, V, and W terminals of the motor. If the motor run direction does not match AC Drive direction indicator light, swap any two terminals connections for T1, T2, and T3.
- To avoid damaging the AC Drive, do not connect the output terminals T1, T2, and T3 to AC input power.
- Connect the ground terminal properly. (240V series: Rg <100Ω; 480V series: Rg <10Ω.)

AC line reactor (output):

- Optional AC line reactor installed on the output of the AC Drive can help to protect the motor from a short circuit of the AC Drive and smooth the current waveform for a cooler running motor. It is also recommended to use an AC line reactor if wiring to the motor is longer than 100ft.

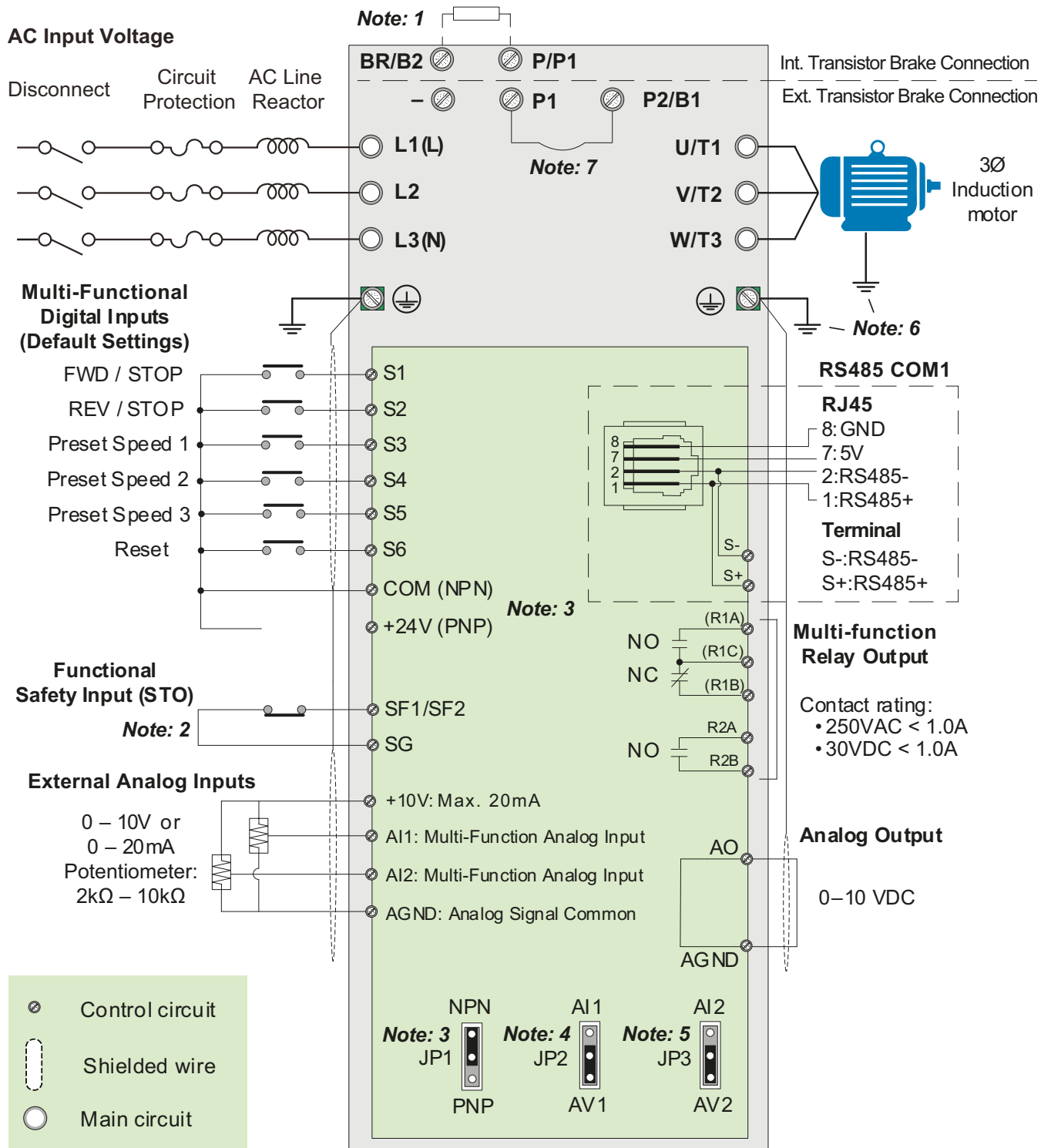
Motor:

- If the AC Drive controls multiple motors, the output rated current of the AC Drive must be greater than the total current of all the motors.

Braking Resistor (not shown):

- Optional braking resistors allow the AC Drive to produce additional stopping torque. Braking resistors may be desired when a quicker deceleration is needed or with high-inertia loads. See section 3.9 for braking resistor wiring.

3.7 General Wiring Diagram



Notes:

- 1: Only 240V 0.5-25HP and 480V 1-30HP have a built-in braking transistor. A braking resistor can be connected directly between BR and P or B2 and P1. Others require braking unit and resistor. See section 3.17 for details.
- 2: Functional Safety input SF and SG should be a normally closed input. This input should be closed to enable the AC Drive output. A jumper is placed between SF and SG from the factory.
- 3: Use jumper JP1 to select between Sink (NPN, with –24V common, factory default) or Source (PNP, with +24V common) for multi-function digital input terminals S1–S6.
- 4: Use jumper JP2 to switch between voltage and current input for Multi-function analog input 1 (AI1).
- 5: Use jumper JP3 to switch between voltage and current input for Multi-function analog input 2 (AI2).
- 6: Grounding impedance: 240V class - less than 100Ω; 480V class - less than 10Ω. Greater impedance indicates a poor ground.
- 7: Factory Jumper. Remove if using a DC Bus Choke. See section 3.17 for details.

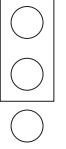
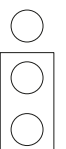
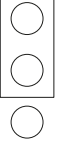
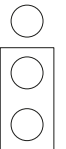
3.8 Control Circuit Terminals and Jumpers

R2A	R2B	R1A	R1B	R1C		S1	S3	S5	24V	AI1	AI2
S(+)	S(-)	SF1	SG		COM	S2	S4	S6	AGND	10V	AO

Type	Terminal	Terminal function	Signal level
Digital inputs	S1	Refer to parameter group 3 for more information and default settings.	24 VDC, 8 mA, Optical coupling isolation (Max, voltage 30 VDC, Input impedance 3.3kΩ) High Logic: 13V Low Logic: 10V
	S2		
	S3		
	S4		
	S5		
	S6		
Relay outputs	R1A	NO (Normally open)	250VAC/1A(30VDC/1A)
	R1B	NC (Normally closed)	
	R1C	COMMON	
	R2A	Multi-function output: Run, Fault, setting Frequency ,Frequency Reached, Auto Restart, Momentary AC Power Loss, Rapid Stop ,Base Block Stop Mode, Motor Overload Protection, Drive Overload Protection, Over-torque Threshold Level、Preset Current level Reached、Preset Brake Frequency Reached, PID Feedback Signal Loss, Final count value reached, Initial count value reached, PLC Status Indicator ,PLC control...	
	R2B		
24V Power supply	COM	Digital signal common terminal (JP1 Switching NPN position)	±15%,Max output current 60mA
	24V	Digital signal common terminal (JP1 Switching PNP position)	
Analog inputs	10V	Built in Power for an external speed potentiometer	10V(Max current:20mA)
	AI1/AV1	Multifunctional analog input: JP2 selects voltage or current input	0 – 10V,(Max current:20mA) (Input impedance: 153KΩ)
		Voltage: JP2 in AV1 position	
		Current: JP2 in AI1 position	
	AI2/AV2	Multifunctional analog input: JP3 selects voltage or current input	0 – 10V,0 –20mA (Input impedance: 153KΩ)
		Voltage: JP3 in AV2 position	
Current: JP3 in AI2 position			
AGND	The analog common terminal	----	
Analog output	AO	Multifunctional analog output terminal*3	0 –10V,(Max current:2mA)
	AGND	Analog common terminal	----
Safety switch	SF1,SF2	Terminal SF is a safety input and can be used to disable drive externally. Note SF2 only available on 'F' version AC Drives.	----
	SG		
RS485 Comms.	S(+)	RS485+	----
	S(-)	RS485-	



- Multi-function analog output AO is for use of an analog output meter. Do not use this output for feedback control.
- Control board's 24V is to be used for internal control only, Do not use the internal power-supply to power external devices.

Jumper	Symbol	Function	Signal Reference	Note
JP1	 1 2 3	NPN/PNP selectable	NPN Input	Factory default setting
	 1 2 3		PNP Input	
JP2/JP3	 1 2 3	External signal type selection	0–20mA / 4–20mA Analog signal	Set parameters 00-05/00-06 to 2 or 3 (external analog input) to become effective
	 1 2 3		0–10VDC / 2–10VDC Analog signal	

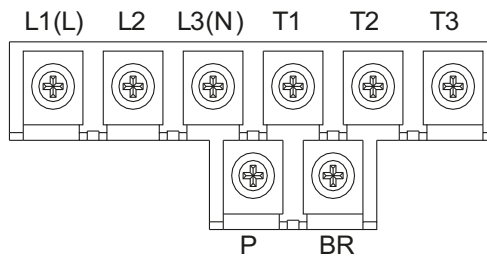
3.9 Power Terminals

Circuit protection must be installed before AC drive. See section 2.3 of the user manual for the appropriate circuit breaker for your drive.

Depending on the AC drive model, terminal labels and layouts may be slightly different. Please see table and diagrams below for details on terminal labels and their functions.

Frame 1 - Three Phase

AC Drive Terminal	Terminal function description
L1(L)	Main power input
L2	
L3(N)	
T1	AC Drive output, connect to U/V/W terminals of motor
T2	
T3	
P	Externally connected braking resistor
BR	

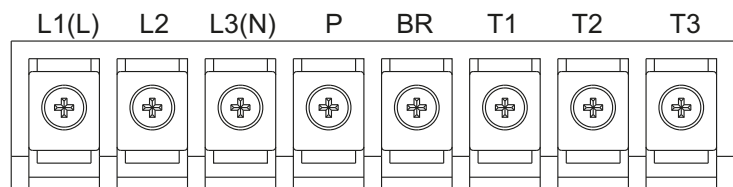


Models:

- TD400-20P5-13PH
- TD400-2001-13PH
- TD400-4001-3PH
- TD400-4002-3PH

Frame 2 - Three Phase

Terminal symbol	Terminal function description
L1(L)	Main power input
L2	
L3(N)	
T1	AC Drive output, connect to U/V/W terminals of motor
T2	
T3	
P	Externally connected braking resistor
BR	

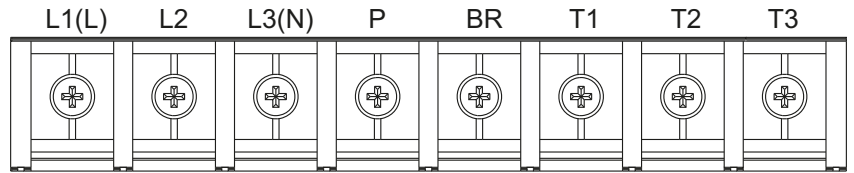


Models:

- TD400-2002-13PH
- TD400-2003-13PH
- TD400-2005-3PH
- TD400-4003-3PH
- TD400-4005-3PH

Frames 3 & 4 - Three Phase

Terminal symbol	Terminal function description
L1(L)	Main power input
L2	
L3(N)	
T1	AC Drive output, connect to U/V/W terminals of motor
T2	
T3	
P	Externally connected braking resistor
BR	

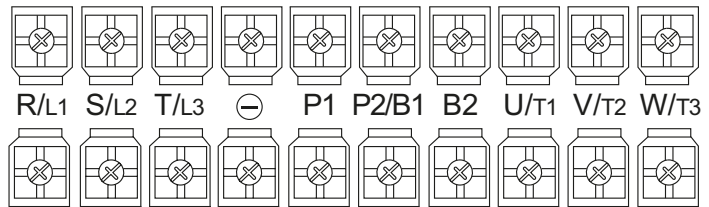


Models:

- TD400-27P5-3PH
- TD400-2010-3PH
- TD400-47P5-3PH
- TD400-4010-3PH
- TD400-4015-3PH
- TD400-2015-3PH
- TD400-2020-3PH
- TD400-4020-3PH
- TD400-4025-3PH

Frame 5 - Three Phase

Terminal symbol	Terminal function description
R/L1	Main power input
S/L2	
T/L3	
U/T1	AC Drive output, connect to U/V/W terminals of motor
V/T2	
W/T3	
P1	Externally connected braking resistor
B2	
P2/B1	Externally connected braking unit (optional)
-	
P1	Externally connected DC Bus Choke (optional)
P2/B1	



Models:

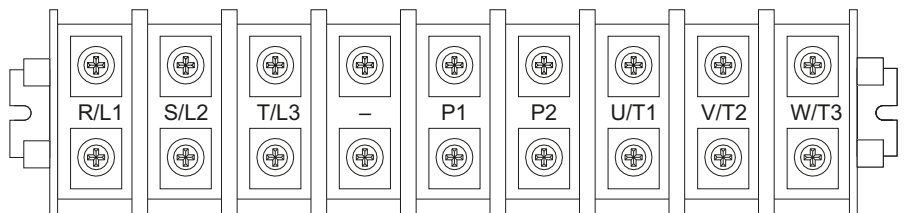
- TD400-2025-3PH
- TD400-4030-3PH

Note:

P1 and P2/B1 are jumpered from the factory. If using a DC Bus Choke, remove jumper.

Frame 6 - Three Phase

Terminal symbol	Terminal function description
R/L1	Main power input
S/L2	
T/L3	
U/T1	AC Drive output, connect to U/V/W terminals of motor
V/T2	
W/T3	
P1	Externally connected braking unit
-	
P1	Externally connected DC Bus Choke (optional)
P2	



Models:

- TD400-2030-3PH
- TD400-2040-3PH
- TD400-4040-3PH
- TD400-4050-3PH
- TD400-4060-3PH
- TD400-4075-3PH

Note:

P1 and P2 are jumpered from the factory. If using a DC Bus Choke, remove jumper.

3.10 AC Drive Wiring

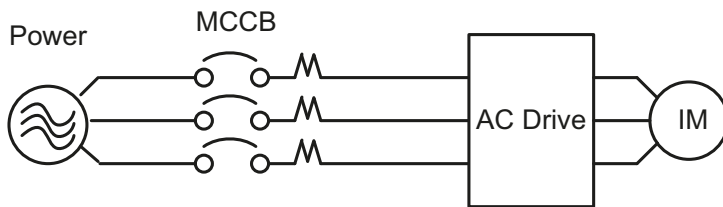


- Do **NOT** remove any protective covers or attempt any wiring while input power is applied. Connect all wiring before applying input power. When making wiring changes after power up, remove input power and wait a minimum of five minutes after power has been turned off before starting. Also confirm that the charge lamp is off and that DC voltage between terminals B1/P or (+) and (-) does not exceed 25V, otherwise **electric shock may result**.
- Only authorized personnel should work on the equipment. Take off metal jewelry such as watches and rings and use insulated tools, otherwise **electric shock or injury may result**.

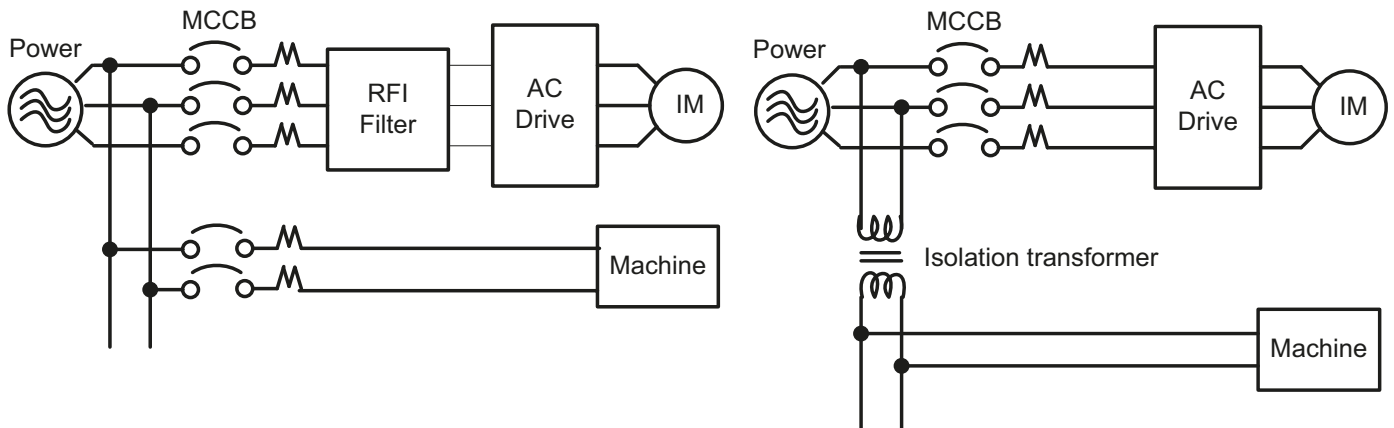
(A) Power input terminals

1. The Input power supply voltage can be connected in any phase sequence to power input terminals R/L1, S/L2, or T/L3 on the terminal block.
2. DO NOT connect the AC input power source to the output terminals U/T1, V/T2 and. W/T3.
3. Connect the output terminals U/T1, V/T2, W/T3 to motor lead wires U/T1, V/T2, and W/T3, respectively.
4. Check that the motor rotates forward with a forward run command. If it does not, swap any 2 output cables to change motor direction.
5. DO NOT connect phase correcting capacitors or a LC/RC noise filter to the output circuit.

Example Power Connections – AC Drive with dedicated power line

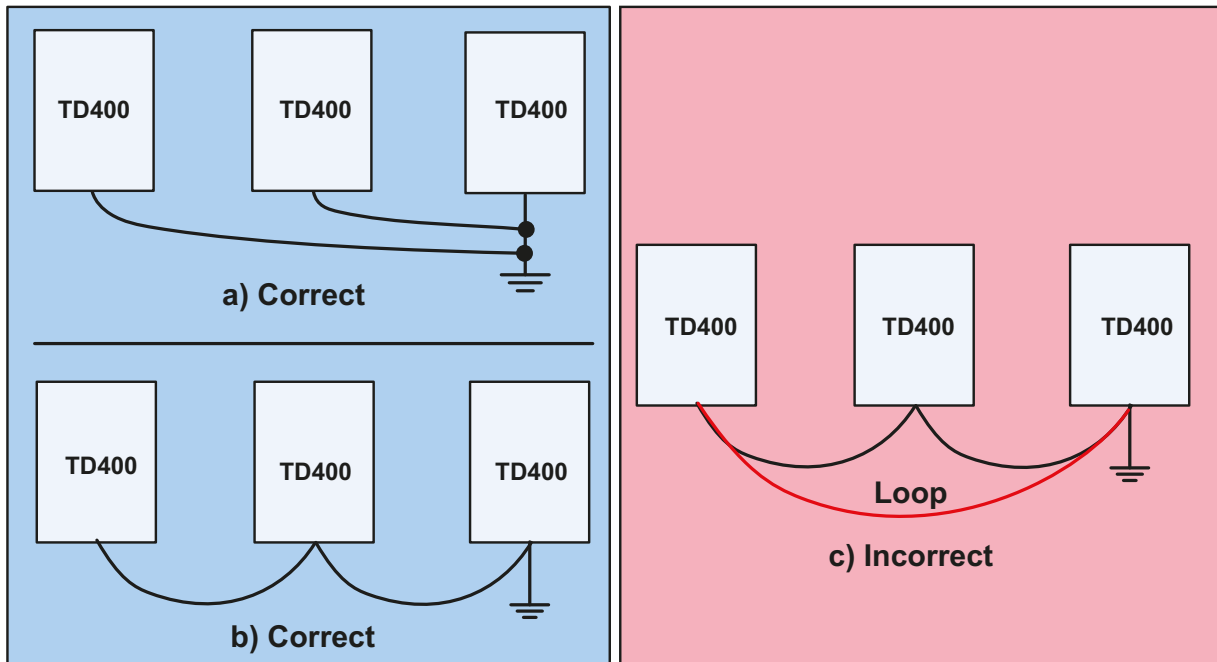


Install a Supply RFI filter or isolation transformer when the power source is shared with other high power electrical equipment as shown below.



(B) Grounding

1. Connect the ground terminal to ground with a resistance of less than 100Ω.
2. Do not share the ground wire with other devices, such as welding machines or power tools.
3. Always use a ground wire that complies with the local codes and standards for electrical equipment and minimize the length of ground wire.
4. When using more than one AC Drive, be careful not to loop the ground wire, as shown below in figure below.



3.11 Input Power and Motor Cable Length

The length of the cables between the input power source, the motor, and AC Drive can cause a significant phase to phase voltage reduction due to the voltage drop across the cables. If this value is exceeded, a larger diameter wire size may be needed. To calculate phase to phase voltage drop, use the following formula:

$$\text{Phase-to-phase voltage drop (V)} = \sqrt{3} \times \text{resistance of wire } (\Omega/\text{km}) \times \text{length of line (m)} \times \text{current} \times 10^{-3}.$$

(km=3280 x feet)
(m=3.28 x feet)

3.12 Cable Length vs. Carrier Frequency

The allowable setting of the PWM carrier frequency is also determined by motor cable length and is specified in the following table.

Cable length between the AC Drive and Motor in m (ft.).	< 30m (100)	30 – 50 (100 – 165)	50 – 100 (166 - 328)	> 100 (329)
Recommended carrier frequency allowed Parameter 11-01	16kHz (max)	10 kHz (max)	5 kHz (max)	2 kHz (max)

3.13 Installing an AC Line Reactor

If the AC Drive is connected to a large-capacity power source (600kVA or more), install an optional AC reactor on the input side of the AC Drive. This also improves the power factor on the power supply side.

3.14 Power Wire Size and Disconnect or Circuit Protection

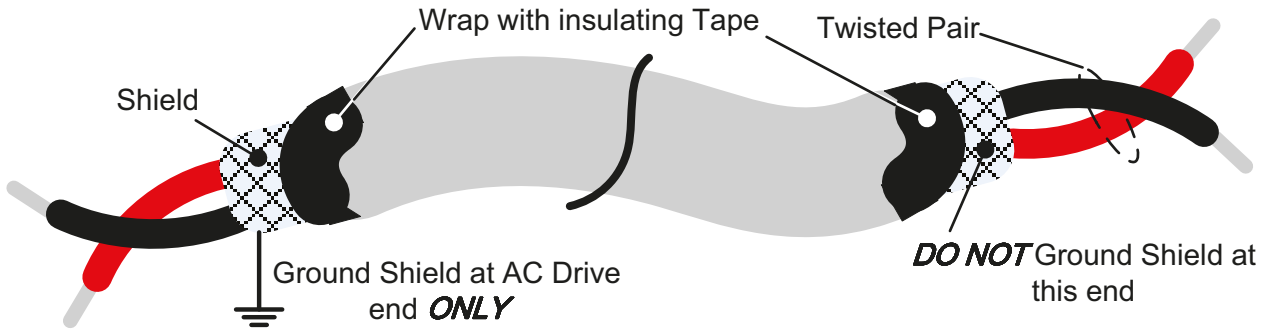
Refer to section 2.2 for the recommended wire size for each frame of the TD400. Installation of circuit breaker will depend on the application. Disconnect or Circuit Protection Device must be installed between the input power supply and the AC Drive input (L1 (L), L2, L3 (N)).

Notes:

1. Proper circuit protection should be provided according to NEC and any local codes and regulations.
2. When using a ground protection make sure the current setting is above 200mA and trip delay time is 0.1 sec or higher.

3.15 Control Circuit Wiring

- (1) Isolate wiring for control circuit terminals from main circuit wiring terminals (R/L1, S/L2, T/L3, U/T1, V/T2, W/T3).
- (2) Isolate the wiring for control circuit terminals R1A-R1B-R1C or R2A, R2B (Relay outputs) from wiring for terminals S1 – S6, A0, AGND, +10V, AI1, AI2 and GND wiring.
- (3) Use shielded twisted-pair cables (#24 - #14 AWG / 0.5 -2 mm²) shown in the figure below for control circuits to minimize noise problems. The maximum wiring distance should not exceed 50m (165 ft).



3.16 AC Drive derating based on Carrier Frequency

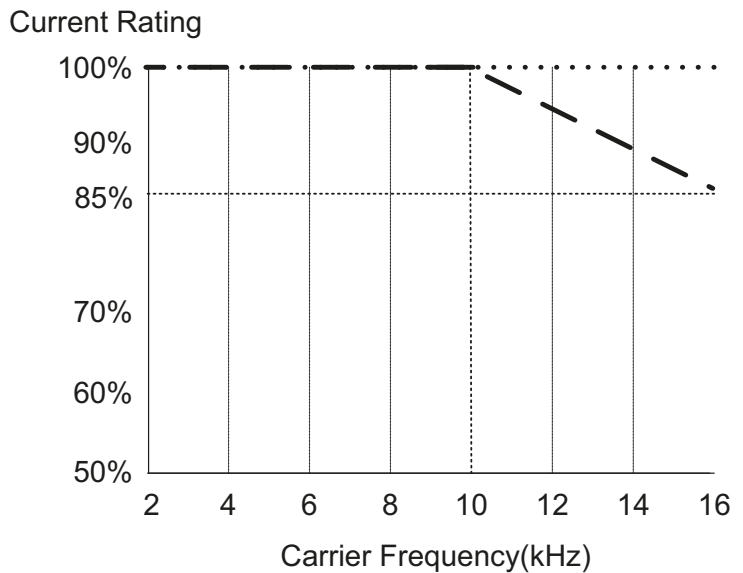
The curves are showing the applicable output current de-rate due to setting of carrier frequency and the ambient operating temperatures of 40 and 50 degrees.

When the carrier frequency is below 10 KHz, ambient temperature will not affect rated current.

When the carrier frequency is higher than 10 KHz

- If the ambient temperature is below 40°C (104°F), 100% output rated current at 16 KHz.
- If the ambient temperature is below 50°C (122°F), 85% output rated current at 16 KHz.

It is required to derate 1.5% of output rated current each additional degree when the ambient temperature rises above 50 degrees °C (122°F).



Note: De-rate curve for ambient temperature of 104°F (40°C)
 - - - - - De-rate curve for ambient temperature of 122°F (50°C)

3.17 Braking resistors

AC Drive			Braking Unit		Resistor Unit		Braking resistor Specification		Duty Cycle	Braking torque	Minimum Resistance	
V	HP	KW	Model	Qty Req.	Model	Qty Req.	(Ω)	(W)	(%)	(%)	(Ω)	(W)
220V 1Ph/ 3Ph	0.5	0.4	Includes Transistor		DBR-2001-C	1	200	150	10	214	70	210
	1	0.75	Includes Transistor		DBR-2001-C	1	200	150	10	117	70	210
	2	1.5	Includes Transistor		DBR-2002-C	1	100	150	10	117	70	210
	3	2.2	Includes Transistor		DBR-2003-C	1	70	260	10	112	70	210
220V 3Ph	5	4	Includes Transistor		DBR-2005-C	1	40	390	10	117	30	500
	7.5	5.5	Includes Transistor		DBR-27P5-C	1	30	520	10	123	25	600
	10	7.5	Includes Transistor		DBR-2010-C	1	20	780	10	117	15	1000
	15	11	Includes Transistor		DBR-2015	1	13.6	2400	10	100	10	1500
	20	15	Includes Transistor		DBR-2015	1	13.6	2400	10	100	10	1500
	25	18.5	Note:1	–	DBR-2025	1	8	4800	10	119	7	2400
	30	22	TBU-230	1	DBR-2030	1	6.8	4800	10	117	5.5	3000
	40	30	TBU-230	2	DBR-2040-KIT	1	10	3000	10	119	5.5	3000
480V 3Ph	1	0.75	Includes Transistor		DBR-4001-C	1	750	150	10	123	120	500
	2	1.5	Includes Transistor		DBR-4002-C	1	400	150	10	117	120	500
	3	2.2	Includes Transistor		DBR-4003-C	1	250	260	10	123	10	600
	5	4	Includes Transistor		DBR-4005-C	1	150	400	10	123	60	1000
	7.5	5.5	Includes Transistor		DBR-47P5-C	1	130	600	10	123	50	1200
	10	7.5	Includes Transistor		DBR-4010-C	1	100	800	10	117	50	1200
	15	11	Includes Transistor		DBR-4015	1	50	1600	10	149	50	1200
	20	15	Includes Transistor		DBR-4020	1	40	1500	10	100	25	2400
	25	18.5	Includes Transistor		DBR-4025	1	32	4800	10	120	15	4000
	30	22	Note:1	–	DBR-4030	1	27.2	4800	10	117	14	4800
	40	30	TBU-430	1	DBR-4040	1	20	6000	10	117	19.2	3600
	50	37	TBU-430	2	DBR-4050-KIT	1	32	4800	10	117	19.2	3600
	60	45	TBU-430	2	DBR-4060-KIT	1	27.2	4800	10	117	19.2	3600
75	55	TBU-430	2	DBR-4075-KIT	1	20	6000	10	117	19.2	3600	

Note:

1: TD400-2025-3PH and TD400-4030-3PH models have the option to use either the internal braking transistor or an external braking unit when additional braking power is required. See section 3.9 for wiring details.

It is recommended to use an external braking unit when the required resistor wattage is 10% greater than the resistor specified in the table above. Use the Braking Resistor Wattage formula below to determine resistor size.

Calculating Braking Resistor Wattage

$$W=(V_{pnb} * V_{pnb}) * ED\% / R_{min}.$$

W: braking resistor power (watts)

V_{pnb}: braking voltage (220V=380VDC, 440V=760VDC)

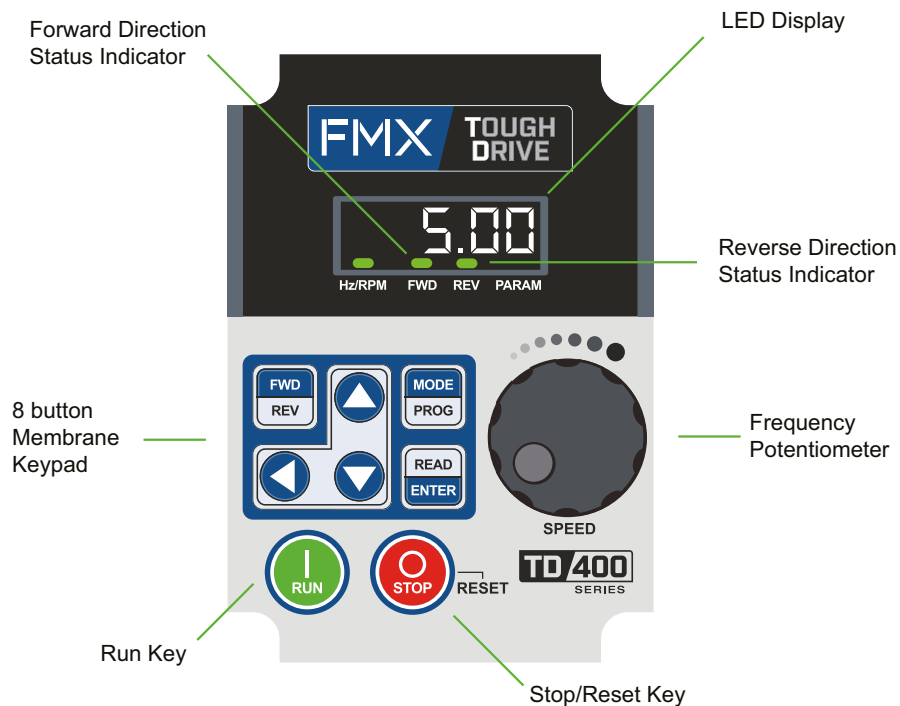
ED%: braking duty cycle









R_{min}: braking resistor minimum value (ohms)

4. User Interface and Programming

4.1 LED Keypad




4.1.1 LED Keypad Display and Keys



DISPLAY	Description
5 Digit LED Display	Monitor AC Drive signals, view / edit parameters, fault / alarm display.
LED INDICATORS	
Hz/RPM	LED ON when frequency or line speed is displayed.
FWD	LED ON when AC Drive is running in forward direction, flashing when stopping.
REV	LED ON when AC Drive is running in reverse direction, flashing when stopping.
PARAM	LED ON when parameters are displayed.
KEYS (8)	Description
RUN	 RUN AC Drive in Local Mode
STOP/RESET	 STOP AC Drive and reset alarms or resettable faults
▲	 Parameter navigation Up, increase parameter or reference value
▼	 Parameter navigation Down, decrease parameter or reference value
FWD/REV	 FWD: Forward Run / REV: Reverse Run
MODE/PROG	 MODE: Switch between available display modes PROG: View / Edit parameter value
READ/ENTER	 Used to display parameter settings and save changed parameter settings
◀	 Parameter navigation Back





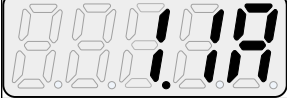




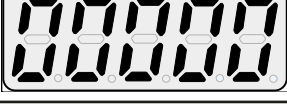
4.1.2 Display Description

Actual	LED Display	Actual	LED Display	Actual	LED Display	Actual	LED Display
0	0	A	A	L	L	Y	Y
1	1	B	B	n	n	-	-
2	2	C	C	o	0	°	0
3	3	D	d	P	P	_	_
4	4	E	E	q	q	.	.
5	5	F	F	r	r		
6	6	G	G	S	S		
7	7	H	H	t	T		
8	8	I	I	u	U		
9	9	J	J	V	V		

LED lights on	LED flashes	Flashing digit
		

At power-up the display will show the frequency reference setting; all LEDs are flashing. Use the keypad potentiometer to adjust set frequency. During run operation the display will show the output frequency.

LED Display Examples

Seven Segment display	Description
	1. Displays the frequency reference at power-up 2. Displays the actual output frequency in run operation.
	Displays parameter code
	Displays the setting value of parameter
	Displays input voltage class (note)
	Displays AC Drive current.
	Displays DC Bus Voltage
	Displays temperature
	Displays PID feedback value. The displayed digit is set by 12-01.
	Error display, refer to Chapter 7 Troubleshooting and maintenance
	Analog Current / Voltage AI1 / AI2. Range (0–1000)

Note: When power is applied to the drive, the display will temporarily flash the input voltage class of that model. This display uses the same unit (small “v”) as the output voltage monitor.

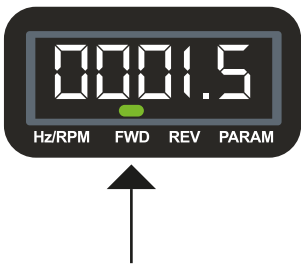
4.1.3 LED Status Description

Hz/RPM LED



State	Description	Hz/RPM LED
Off	Display doesn't show frequency or line speed	
Illuminated	Display shows frequency or line speed	

FWD LED



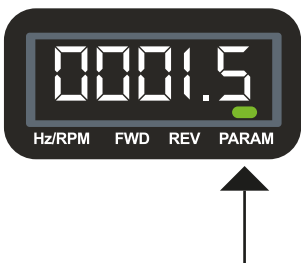
State	Description	Forward LED
Off	AC Drive in reverse direction	
Illuminated	AC Drive is running in forward direction	
Flashing	Forward direction active, no run command	

REV LED



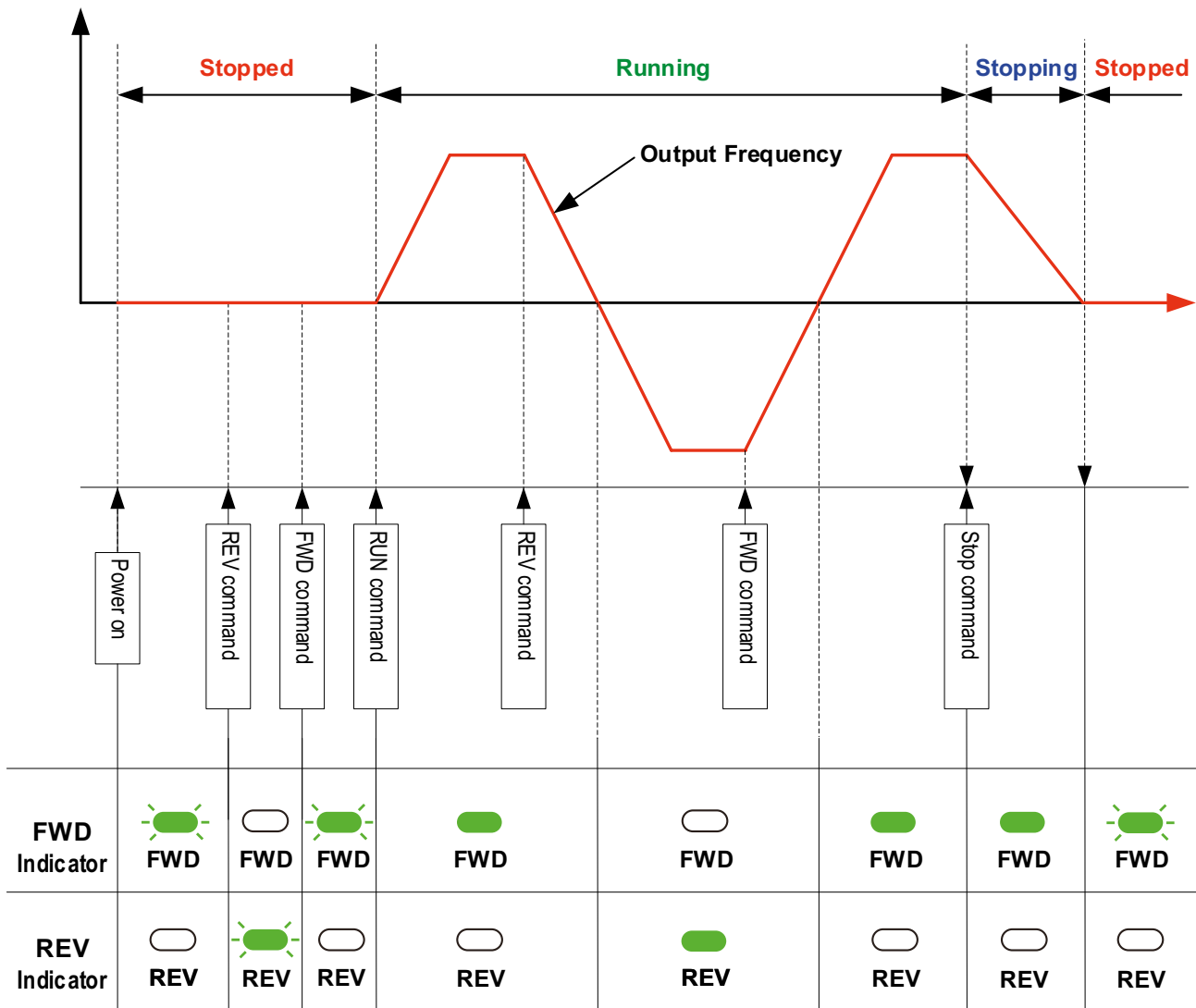
State	Description	Reverse LED
Off	AC Drive in forward direction	
Illuminated	AC Drive is running in reverse direction	
Flashing	Reverse direction active, no run command	

PARAM LED



State	Description	PARAM LED
Off	Display doesn't show parameter	
Illuminated	Display shows parameter	

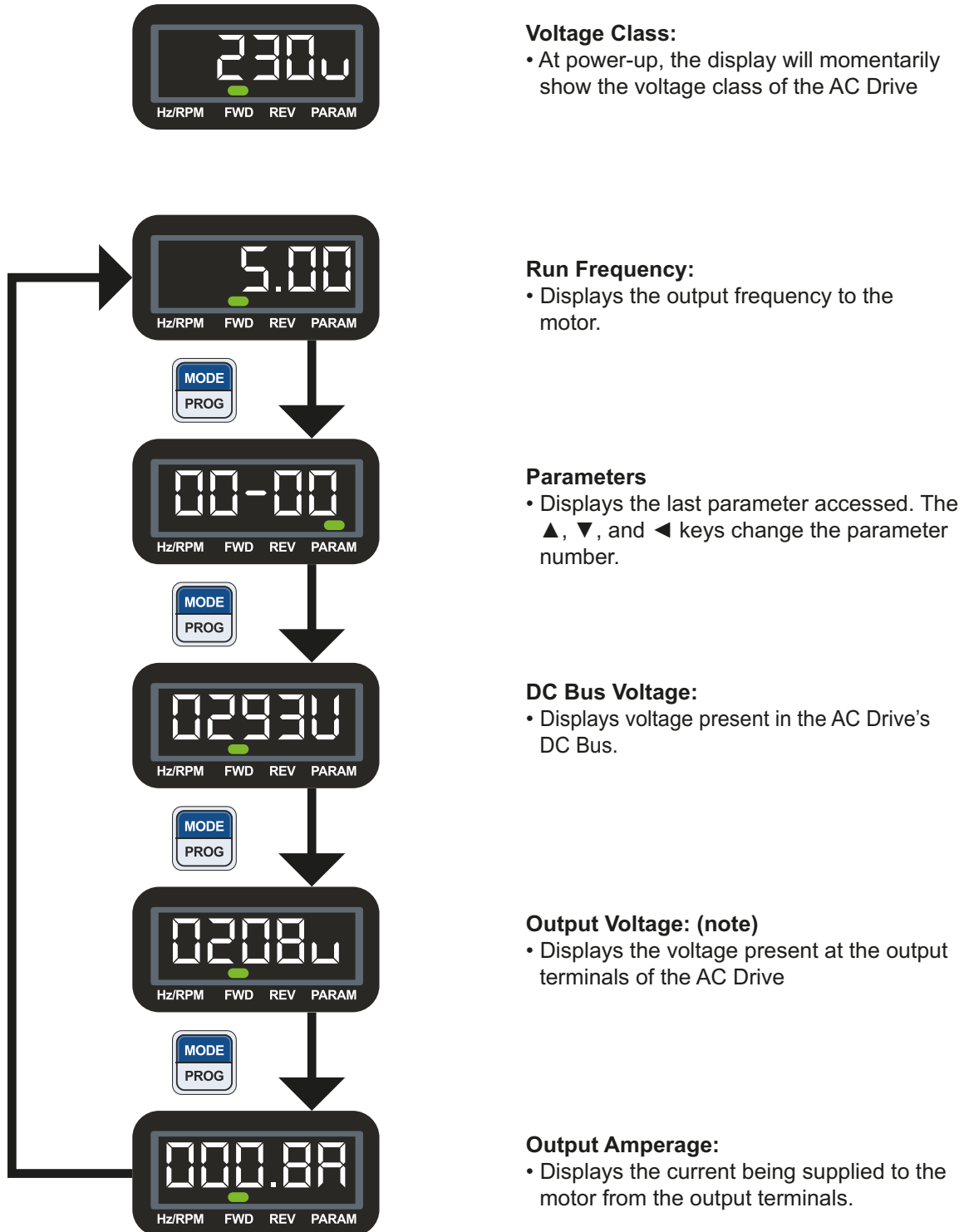
4.1.4 Operation Control



4.1.5 Using the Keypad

Drive Monitoring

The TD400 offers several monitoring functions that can be accessed by pressing the MODE/PROG key on the keypad repeatedly to cycle through the available monitors. The diagram below shows the default sequence of monitors in the TD400 drive. See parameter 12-00 details for instructions on how to change the monitor sequence or add/remove monitors from the sequence.


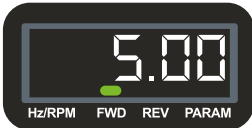






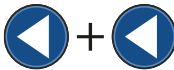













Note: When power is applied to the drive, the display will temporarily flash the input voltage class of that model. This display uses the same unit (small “v”) as the output voltage monitor.

Parameter Programming Example

The TD400 can be programmed directly from the keypad. The example below shows how to make changes to a parameter setting. For a complete list of parameters, see section 4.2.

This example we will be setting the motor FLA (02-01 Rated Current Motor 1). Example assumes the drive is at factory default settings, the default value of 02-01 is 3.4A, and the motor uses 1.5A at full load. Refer to motor nameplate for the FLA specific to your application.

Step	Key	Display
1. Power up the AC Drive. Display shows voltage class briefly.		
2. After displaying voltage class, the screen will display setting frequency.		
3. Press MODE/PROG to enter program mode. The second digit from the left will blink indicating selected digit.		
4. The "Rated Current Motor 1" parameter is 02-01. Press UP key twice to change flashing digit to 2.		

Step	Key	Display
5. Press LEFT key twice to select far right digit.		
6. Press UP key once to change flashing digit to 1.		
7. Press the READ/ENTER key to edit parameter 02-01. The default value of 02-01 depends on the drive model.		
8. Press the UP key once to change the flashing digit to 5		
9. Press the LEFT key once to move to the next digit. The 3 will begin to flash.		
10. Press the DOWN key twice to change the flashing digit to 1.		
11. Press the READ/ENTER key to save the parameter. Display will flash -END-.		

Programming parameter 02-01 is complete

4.2 Parameter Summary

Parameter group	Name
Group 00	Basic Parameters
Group 01	V/F Control Parameters
Group 02	Motor Parameters
Group 03	External Digital Input and Output Parameters
Group 04	External Analog Input and Output Parameters
Group 05	Preset Frequency Parameters
Group 06	Automatic Program Operation Parameters
Group 07	Start /Stop Parameters
Group 08	Protection Parameters
Group 09	Communication Parameters
Group 10	PID Parameters
Group 11	Auxiliary Parameters
Group 12	Monitoring Parameters
Group 13	Maintenance Parameters
Group 14	PLC Parameters
Group 15	PLC Monitoring Parameters
Group 16	LCD Parameters
Group 17	Automatic Tuning Parameters
Group 18	Slip Compensation Parameters
Group 20	Speed Control Parameters
Group 21	Torque and Position Control Parameters
Group 22	PM Motor Parameters

Parameter Notes	
*1	Parameter can be changed during running.
*3	Parameter will not reset to default during a factory reset (initialization).
*4	Read-only parameter
*5	Parameter will be displayed in being coupled with the option card.
*6	Parameter will be displayed only when using the LED keypad.
*7	Parameter will be displayed only when using the LCD keypad.
*8	Parameter range and default setting is dependent on drive size/model.
*9	Parameter default setting is dependent on drive size/model.

Group 00 Basic Parameters								
Param. #	Parameter Name	Setting Range	Default	Unit	Control mode			Notes
					V/F	SLV	PM/SLV	
00-00	Control Mode Selection	0: V/F	0	-	✓	✓	✓	*3
		2: SLV						
		5: PMSLV						
00-01	Motor's Rotation Direction	0: Forward	0	-	✓	✓	✓	*1
		1: Reverse						
00-02	Main Run Command Source	0: Keypad	0	-	✓	✓	✓	
		1: External Terminal (Control Circuit)						
		2: Communication Control (RS-485)						
		3: PLC						
00-03	Alternative Run Command Source	0: Keypad	2	-	✓	✓	✓	
		1: External Terminal (Control Circuit)						
		2: Communication Control (RS-485)						
		3: PLC						
00-04	Operation Modes for External Terminals	0: Forward/Stop-Reverse/Stop	0	-	✓	✓	✓	*7
		1: Run/Stop- Reverse/Forward						
		2: 3 Wire Control Mode Run/Stop						
00-05	Main Frequency Command Source	0: UP/DOWN from Keypad 1: Potentiometer on Keypad 2: External AI1 Analog Signal Input 3: External AI2 Analog Signal Input 4: External Up/Down Frequency 5: Communication Setting Frequency 6: Reserved 7: Pulse Input	1	-	✓	✓	✓	
00-06	Alternative Frequency Command Source	0: UP/DOWN on Keypad 1: Potentiometer on Keypad 2: External AI1 Analog Signal Input 3: External AI2 Analog Signal Input 4: External Up/Down Frequency 5: Communication Setting Frequency 6: Reserved 7: Pulse Input	0	-	✓	✓	✓	
00-07	Main and Alternative Frequency Command Modes	0: Main or Alternative Frequency	0	-	✓	✓	✓	
		1: Main Frequency + Alternative Frequency						
00-08	Communication Range Frequency Command	0.00–599.00	-	Hz	✓	✓	✓	*4
00-09	Frequency Command Save on Power Down	0: Disabled	0	-	✓	✓	-	
		1: Enabled						
00-10	Initial Frequency (keypad mode)	0: by Current Frequency Command	0	-	✓	✓	✓	
		1: by 0 Frequency Command						
		2: by 00-11						
00-11	Initial Freq. Setpoint	0.00-599.00	Varies	Hz	✓	✓	✓	*9, (Note)
00-12	Frequency Upper Limit	0.01-599.00	Varies	Hz	✓	✓	✓	*9, (Note)

Group 00 Basic Parameters								
Param. #	Parameter Name	Setting Range	Default	Unit	Control Mode			Notes
					V/F	SLV	PM/SLV	
00-13	Frequency Lower Limit	0.00-599.99	0	Hz	✓	✓	✓	(Note)
00-14	Acceleration Time 1	0.1-6000.0	Varies	s	✓	✓	✓	*1, *9
00-15	Deceleration Time 1	0.1-6000.0	Varies	s	✓	✓	✓	*1 *9
00-16	Acceleration Time 2	0.1-6000.0	Varies	s	✓	✓	✓	*1 *9
00-17	Deceleration Time 2	0.1-6000.0	Varies	s	✓	✓	✓	*1 *9
00-18	Jog Frequency	1.00-25.00	2	Hz	✓	✓	✓	*1, *7
00-19	Jog Acceleration Time	0.1-25.5	Varies	s	✓	✓	✓	*1, *7 *9
00-20	Jog Deceleration Time	0.1-25.5	Varies	s	✓	✓	✓	*1, *7 *9
00-21	Acceleration Time 3	0.1-6000.0	Varies	s	✓	✓	✓	*1 *9
00-22	Deceleration Time 3	0.1-6000.0	Varies	s	✓	✓	✓	*1 *9
00-23	Acceleration Time 4	0.1-6000.0	Varies	s	✓	✓	✓	*1 *9
00-24	Deceleration Time 4	0.1-6000.0	Varies	s	✓	✓	✓	*1 *9
00-26	Emergency Stop Time	0.1-3600.0	5	s	✓	✓	✓	
00-27	HD/ND Mode (F5/F6 Only)	0: HD (Constant Torque)	0	-	✓	X	X	(Note)
		1: ND (Variable Torque)						
00-34	Language (For external LCD keypad only)	0: English	0	-	✓	✓	✓	
		1: Simplified Chinese						
		2: Traditional Chinese						
		3: Turkish						
00-35	Minimum Frequency Detection	0: Alarm	0	-	✓	✓	✓	
		1: Keep Running At Lower Frequency						
00-36	PID Lower Frequency Selection	0: Lower Frequency of PID Sleep Mode (disable)	0	-	✓	✓	✓	
		1: 0Hz of PID Sleep Mode (enable)						

00-11:

Initial Frequency Setpoint range depends on the setting of 01-02 and 01-08 or 01-16 and 01-22 for V/F and SLV modes. Depends on 22-06 for PMSLV mode.

00-12:

Frequency upper limit range depends on the setting of 01-02 or 01-16 for V/F and SLV modes. Depends on 22-06 for PMSLV mode.

00-13:

Frequency lower limit range depends on the setting of 01-08 or 01-22 for V/F and SLV modes. Depends on 22-06 for PMSLV mode.

00-27:

If parameter 00-27 is set to ND mode, group 02 motor 1 parameter will automatically be adjusted.

If parameter 00-27 is set to HD mode, group 02 motor 1 parameter will automatically be adjusted.

It is recommended that parameter 00-27 be set first before performing an auto-tune because motor parameters will be updated automatically.

Applicable to Frames 5 and 6 only.

*1: Parameter can be changed while running.

*3: Parameter will not reset to default during a factory reset (initialization).

*4: Read-only Parameter

*7: Parameter will be displayed only when using the LCD keypad.

*9: Parameter default setting is dependent on drive size/model.

Group 01 Basic Motor Parameters								
Param. #	Parameter Name	Setting Range	Default	Unit	Control Mode			Notes
					V/F	SLV	PM/SLV	
01-00	V/F Curve Motor 1	0–FF	1	-	✓	X	X	*3, (Note)
01-02	Maximum Output Frequency Motor 1	4.8–599.0	50.0/60.0	Hz	✓	✓	✓	*8
01-03	Maximum Output Voltage Motor 1	240V: 0.1–255.0	230	V	✓	X	X	*8
		480V: 0.2–510.0	460					
01-04	Middle Output Frequency 2 Motor 1	0.1–599.0	0	Hz	✓	X	X	(Note)
01-05	Middle Output Voltage 2 Motor 1	240V: 0.0–255.0	0	V	✓	X	X	*8, (Note)
		480V: 0.0–510.0						
01-06	Middle Output Frequency 1 Motor 1	0.1–599.0	3	Hz	✓	X	X	(Note)
01-07	Middle Output Voltage 1 Motor 1	240V: 0.0–255.0	Per Model	V	✓	X	X	*8, (Note)
		480V: 0.0–510.0						
01-08	Minimum Output Frequency Motor 1	0.1–599.0	V/F: 1.5	Hz	✓	✓	✓	*9, (Note)
			SLV: 0.6					
			PMSLV: 10					
01-09	Minimum Output Voltage Motor 1	240V: 0.0–255.0	Per Model	V	✓	X	X	*8
		480V: 0.0–510.0						
01-10	Torque Compensation Gain	0–10.0	0.5	-	✓	X	X	*1
01-11	Torque Compensation Mode	0: Mode 0 (Normal)	0	-	✓	X	X	
		1: Mode 1 (High Speed)						
01-12	Base (nameplate) Frequency Motor 1	4.8–599.0	50.0/60.0	Hz	✓	✓	X	*8
01-13	Base (nameplate) Output Voltage Motor 1	240V: 0.0–255.0	230	V	✓	X	X	*8
		480V: 0.0–510.0	460					
01-14	Input Voltage Setting	240V: 55.0–255.0	230	V	✓	✓	✓	*8
		480V: 10.0–510.0	460					
01-15	Torque Compensation Time	0–10000	200	ms	✓	X	X	
01-16	Maximum Output Frequency Motor 2	4.8–599.0	50.0/60.0	Hz	✓	X	X	*8
01-17	Maximum Output Voltage Motor 2	240V: 0.0–255.0	230	V	✓	X	X	*8
		480V: 0.0–510.0	460					
01-18	Middle Output Frequency 2 Motor 2	0.0–599.0	0	Hz	✓	X	X	
01-19	Middle Output Voltage 2 Motor 2	240V: 0.0–255.0	0	V	✓	X	X	
		480V: 0.0–510.0						
01-20	Middle Output Frequency 1 Motor 2	0.0–599.0	3	Hz	✓	X	X	
01-21	Middle Output Voltage 1 Motor 2	240V: 0.0–255.0	Per Model	V	✓	X	X	*9
		480V: 0.0–510.0						
01-22	Minimum Output Frequency Motor 2	0.0–599.0	1.5	Hz	✓	X	X	
01-23	Minimum Output Voltage Motor 2	240V: 0.0–255.0	Per Model	V	✓	X	X	*9
		480V: 0.0–510.0						
01-24	Base (nameplate) Frequency Motor 2	4.8–599.0	50.0/60.0	Hz	✓	X	X	*8
01-25	Base (nameplate) Output Voltage Motor 2	240V: 0.0–255.0	230	V	✓	X	X	*8
		480V: 0.0–510.0	460					
01-26	V/F Curve Motor 2	0–FF	F	-	✓	X	X	*3

01-00:

When editing using the LED keypad, display shows H00XX indicating the value is to be input as a hexadecimal.

01-04 to 01-07 and 01-18 to 01-21: Values are only editable when 01-00=F or FF

*1: Parameter can be changed while running.

*3: Parameter will not reset to default during a factory reset (initialization).

*8: Parameter range and default setting is dependent on drive size/model.

*9: Parameter default setting is dependent on drive size/model.

Group 02 IM Motor Parameters								
Param. #	Parameter Name	Setting Range	Default	Unit	Control Mode			Notes
					V/F	SLV	PM/SLV	
02-00	No-Load Current Motor 1	0.01–600.00	Per Model	A	✓	X	X	*9
02-01	Rated Current Motor 1	V/F mode: 10%–200% of AC Drive rated current. SLV mode: 25%–200% of AC Drive rated current.	Per Model	A	✓	✓	X	*9
02-03	Rated Rotation Speed Motor 1	0–60000	Per Model	rpm	✓	✓	X	*9
02-04	Rated Voltage Motor 1	240V: 50.0–240.0	230.0	V	✓	✓	X	*8
		480V: 100.0–480.0	460.0					
02-05	Rated Power Motor 1	0.01–600.00	Per Model	kW	✓	✓	X	*9
02-06	Rated Frequency Motor 1	4.8–599.0	50.0/60.0	Hz	✓	✓	X	*8
02-07	Motor 1 Pole Number	2–16(Even)	4	-	✓	✓	X	
02-09	Excitation Current Motor 1	15%–70% of motor rated current	-	%	X	✓	X	(Note)
02-10	Core Saturation Coefficient 1	1–100	Per Model	%	X	✓	X	*9
02-11	Core Saturation Coefficient 2 Motor 1	1–100	Per Model	%	X	✓	X	*9
02-12	Core Saturation Coefficient 3 Motor 1	80–300	Per Model	%	X	✓	X	*9
02-13	Core loss Motor 1	0.0–15.0	Per Model	%	✓	X	X	*9
02-15	Line-to-line Resistance Motor 1	1–60000	Per Model	Ω	✓	X	X	*9
02-17	Leakage Inductance Motor 1	0.01–200.00	Per Model	mH	✓	✓	X	*9
02-19	No-Load Voltage Motor 1	240V: 50–240	Per Model	V	X	✓	X	*9
		480V: 100–480						
02-20	No-Load Current Motor 2	0.01–600.00	Per Model	A	✓	X	X	*9
02-21	Rated Current Motor 2	10%–200% of AC Drive rated current	Per Model	A	✓	X	X	*9
02-22	Rated Rotation Speed Motor 2	0–60000	Per Model	Rpm	✓	X	X	*8
02-23	Rated Voltage Motor 2	240V: 50.0–240.0	230.0	V	✓	X	X	
		480V: 100.0–480.0	460.0					
02-24	Rated Power Motor 2	0.01–600.00	Per Model	kW	✓	X	X	*9
02-25	Rated Frequency Motor 2	4.8–599.0	50.0/60.0	Hz	✓	X	X	*8
02-26	Motor 2 Pole Number	2–16 (Even)	4	-	✓	X	X	
02-32	Line-to-line Resistance Motor 2	0.001–60.000	Per Model	Ω	✓	X	X	*9
02-33	Proportion of Motor Leakage Inductance	0.1–15.0	Per Model	%	X	✓	X	*9
02-34	Motor Slip Frequency	0.10–20.00	Per Model	Hz	X	✓	X	*9

02-09:

It is not recommended to adjust this parameter. Use caution when adjusting Excitation Current.

*8: Parameter range and default setting is dependent on drive size/model.

*9: Parameter default setting is dependent on drive size/model.

Group 03 External Digital Input and Output Parameters								
Param. #	Parameter Name	Default	Setting Range	Unit	Control Mode			Notes
					V/F	SLV	PM/SLV	
03-00	Multifunction Input Terminal S1	0	0: Forward/Stop Command 1: Reverse/Stop Command 2: Multi-Speed/Position Setting Command 1 3: Multi-Speed/Position Setting Command 2 4: Multi-Speed/Position Setting Command 3 5: Multi-Speed/Position Setting Command 4	-	See parameter details			
03-01	Multifunction Input Terminal S2	1	6: Forward Jog Run Command 7: Reverse Jog Run Command 8: UP Frequency Increasing Command 9: DOWN Frequency Decreasing Command 10: Acceleration/ Deceleration Time Selection 11: Inhibit Acceleration/ Deceleration Command					
03-02	Multifunction Input Terminal S3	2	12: Main/ Alternative Run Switch Function 13: Main/ Alternative Frequency Switch Function 14: Emergency Stop (decelerate to zero and stop) 15: External Baseblock Command (coast to stop) 16: PID Control Disabled					
03-03	Multifunction Input Terminal S4	3	17: Fault Reset 18: Auto Run Mode Enable 19: Speed Search 20: Energy Saving 21: Reset PID integral value to Zero 22: Counter Input 23: Counter reset					
03-04	Multifunction Input Terminal S5	4	24: PLC Input 25: Pulse width modulation measurement (S3 only) 26: Pulse frequency measure (S3 only) 27: Local/Remote selection 28: Remote mode selection 29: Jog Frequency Selection					
03-05	Multifunction Input Terminal S6	17	33: DC Braking 34: Speed Search 2 40: Motor 1/Motor 2 selection 47: Fire mode 48: KEB Acceleration 65: Short-circuit braking 66: PID Control Disable 2 68: External Fault 69: Fire Mode External Overload 70: 2-wire Jog					

03-0X=25 and 03-0X=26: Terminal S3 only.

03-0X=47: Terminal S6 only.

03-0X=69: Terminal S5 only.

Group 03 External Digital Input and Output Parameters								
Param. #	Parameter Name	Setting Range	Default	Unit	Control mode			Notes
					V/F	SLV	PM/SLV	
03-08	S1-S6 scan time	1-200	1	-	✓	✓	✓	
03-09	S1- S4 switch type select	xxx0b: S1 A Contact xxx1b: S1 B Contact xx0xb: S2 A Contact xx1xb: S2 B Contact x0xxb: S3 A Contact x1xxb: S3 B Contact 0xxxb: S4 A Contact 1xxxb: S4 B Contact	0000b	-	✓	✓	✓	
03-10	S5- S6 switch type select	xxx0b: S5A Contact xxx1b: S5 B Contact xx0xb: S6 A Contact xx1xb: S6 B Contact	0000b	-	✓	✓	✓	
03-11	Relay (R1A-R1C) Output	0: During Running 1: Fault Contact Output 2: Frequency Agree 3: Setting Frequency Agree (03-13±03-14) 4: Frequency Detection 1 (≥03-13+03-14) 5: Frequency Detection 2 (≤03-13+03-14) 6: Automatic Restart 7: Momentary AC Power Loss 8: Rapid Stop 9: Base Block 10: Motor Overload Protection (OL1)	1	-	See parameter details			
03-12	Relay (R2A-R2B) Output	11: Drive Overload Protection (OL2) 12: Over-torque Threshold Level (OL3) 13: Preset Output Current Reached 14: Brake Control 15: PID Feedback Signal Loss 16: Single pre-set count (3-22 & 3-23) 17: Dual pre-set count (3-22 & 3-23) 18: PLC Status Indicator (00-02) 19: PLC control * 20: Zero Speed 30: Motor 2 Selection 54: Turn on short-circuit braking 55: Low Current Detection 59: Overheat Detection	0	-				

Group 03 External Digital Input and Output Parameters								
Param. #	Parameter Name	Setting Range	Default	Unit	Control mode			Notes
					V/F	SLV	PM/SLV	
03-13	Freq. Detection Level	0.0–599.0	0	Hz	✓	✓	✓	
03-14	Freq. Detection Width	0.1–25.5	2	Hz	✓	✓	✓	
03-15	Current Agree Level	0.1–999.9	0.1	A	✓	✓	✓	
03-16	Current Agree Detection Delay Time	0.1–10.0	0.1	s	✓	✓	✓	
03-17	Mechanical Braking Release Level	0.00–599.00	0	Hz	✓	✓	✓	(Note)
03-18	Mechanical Braking Level Set	0.00–599.00	0	Hz	✓	✓	✓	(Note)
03-19	Relay (R1A-R2A) Type	xxx0b: R1 A Contact xxx1b: R1 B Contact	0000b	-	✓	✓	✓	
		xx0xb: R2 A Contact xx1xb: R2 B Contact						
03-20	Internal / External Multi-Function Input Terminal Selection	0–63	0	-	✓	✓	✓	
03-21	Action To Set The Internal Multi-Function Input Terminals	0–63	0	-	✓	✓	✓	
03-22	Pre-Set Count 1	0–9999	0	-	✓	✓	✓	
03-23	Pre-Set Count 2	0–9999	0	-	✓	✓	✓	
03-24	Output Under Current Detection	0: Invalid	0	-	✓	✓	✓	
		1: Valid						
03-25	Output Under Current Detection Level	0–999.9	0.1	A	✓	✓	✓	
03-26	Output Under Current Detection Delay Time	0.0–655.34	0.01	s	✓	✓	✓	
03-27	UP/DOWN Frequency Hold/Adjust Selection	0: Hold last set frequency when stopped 1: Set frequency to 0 when stopped 2: Allow speed changes from last set frequency when stopped 3: Refresh frequency at acceleration.	0	-	✓	✓	✓	
03-30	Pulse Input	0: General Pulse Input	0	-	✓	✓	✓	
		1: PWM						
03-31	Pulse Frequency	50–25000	1000	Hz	✓	✓	✓	*1
03-32	Pulse Input Gain	0.0–1000.0	100	%	✓	✓	✓	*1
03-33	Pulse Input Bias	-100.0–100.0	0	%	✓	✓	✓	
03-34	Filter Time of Pulse Input	0.00–2.00	0.1	Sec	✓	✓	✓	
03-40	UP/DOWN Frequency Width Setting	0.00–5.00	0.00	Hz	✓	✓	✓	
03-53	Current Agree Level 2	0.1–999.9	0.0	A	✓	✓	✓	

03-17 to 03-18: If the maximum output frequency of motor is over 300HZ, the frequency resolution is changed to 0.1Hz

*1: Parameter can be changed while running.

Group 04 Analog signal inputs / Analog output								
Param. #	Parameter Name	Setting Range	Default	Unit	Control Mode			Notes
					V/F	SLV	PM/SLV	
04-00	Analog Input Signal Type	0: AI1 0–10V / 0–20mA AI2 0–10V / 0–20mA	1	-	✓	✓	✓	
		1: AI1 0–10V / 0–20mA AI2 2–10V / 4–20mA						
		2: AI1 2–10V / 4–20mA AI2 0–10V / 0–20mA						
		3: AI1 2–10V / 4–20mA AI2 2–10V / 4–20mA						
04-01	AI1 Signal Scanning and Filtering Time	0.00–2.00	0.03	s	✓	✓	✓	
04-02	AI1 Gain	0.0–1000.0	100	%	✓	✓	✓	*1
04-03	AI1 Bias	0–100.0	0	%	✓	✓	✓	*1
04-04	AI1 Bias Selection	0: Positive 1: Negative	0	-	✓	✓	✓	
04-05	AI1 Slope	0: Positive	0	-	✓	✓	✓	
		1: Negative						
04-06	AI2 Signal Scanning and Filtering Time	0.00–2.00	0.03	s	✓	✓	✓	
04-07	AI2 Gain	0.0–1000.0	100	%	✓	✓	✓	
04-08	AI2 Bias	0–100.0	0	%	✓	✓	✓	
04-09	AI2 Bias Selection	0: Positive 1: Negative	0	-	✓	✓	✓	
04-10	AI2 Slope	0: Positive	0	-	✓	✓	✓	
		1: Negative						
04-11	Analog Output (AO) Mode	0: Output Frequency	0	-	✓	✓	✓	
		1: Frequency Command						
		2: Output Voltage						
		3: DC Bus Voltage						
		4: Output Current						
04-12	AO Gain	0.0–1000.0	100	%	✓	✓	✓	
04-13	AO Bias	0–100.0	0	%	✓	✓	✓	
04-14	AO Bias Selection	0: Positive 1: Negative	0	-	✓	✓	✓	
04-15	AO Slope	0: Positive	0	-	✓	✓	✓	
		1: Negative						
04-20	AO Signal Scanning and Filtering Time	0.00–0.50	0	s	✓	✓	✓	
04-22	F-Gain	0: Disable 1: Enable	0	-	✓	✓	✓	
04-25	AO Voltage Auto Tuning	0: Disable 1: Enable	0	-	✓	✓	✓	

*1: Parameter can be changed while running.

Group 05 Preset Frequency Selection								
Param. #	Parameter Name	Setting Range	Default	Unit	Control mode			Notes
					V/F	SLV	PMSLV	
05-00	Preset Speed Control Mode Selection	0: Accel/Decel 1-4 apply to all speeds	0	-	✓	✓	✓	
		1: Individual Accel/Decel for each preset speed						
05-01	Preset Speed 0	0.00-599.00	5	Hz	✓	✓	✓	*1, (Note)
05-02	Preset Speed 1	0.00-599.00	5	Hz	✓	✓	✓	*1, (Note)
05-03	Preset Speed 2	0.00-599.00	10	Hz	✓	✓	✓	*1, (Note)
05-04	Preset Speed 3	0.00-599.00	20	Hz	✓	✓	✓	*1, (Note)
05-05	Preset Speed 4	0.00-599.00	30	Hz	✓	✓	✓	*1, (Note)
05-06	Preset Speed 5	0.00-599.00	40	Hz	✓	✓	✓	*1, (Note)
05-07	Preset Speed 6	0.00-599.00	50	Hz	✓	✓	✓	*1, (Note)
05-08	Preset Speed 7	0.00-599.00	50	Hz	✓	✓	✓	*1, (Note)
05-09	Preset Speed 8	0.00-599.00	5	Hz	✓	✓	✓	*1, (Note)
05-10	Preset Speed 9	0.00-599.00	5	Hz	✓	✓	✓	*1, (Note)
05-11	Preset Speed 10	0.00-599.00	5	Hz	✓	✓	✓	*1, (Note)
05-12	Preset Speed 11	0.00-599.00	5	Hz	✓	✓	✓	*1, (Note)
05-13	Preset Speed 12	0.00-599.00	5	Hz	✓	✓	✓	*1, (Note)
05-14	Preset Speed 13	0.00-599.00	5	Hz	✓	✓	✓	*1, (Note)
05-15	Preset Speed 14	0.00-599.00	5	Hz	✓	✓	✓	*1, (Note)
05-16	Preset Speed 15	0.00-599.00	5	Hz	✓	✓	✓	*1, (Note)
05-17	Preset Speed 0-Acc time	0.1-6000.0	10	s	✓	✓	✓	
05-18	Preset Speed 0-Dec time	0.1-6000.0	10	s	✓	✓	✓	
05-19	Preset Speed 1-Acc time	0.1-6000.0	10	s	✓	✓	✓	
05-20	Preset Speed 1-Dec time	0.1-6000.0	10	s	✓	✓	✓	
05-21	Preset Speed 2-Acc time	0.1-6000.0	10	s	✓	✓	✓	
05-22	Preset Speed 2-Dec time	0.1-6000.0	10	s	✓	✓	✓	
05-23	Preset Speed 3-Acc time	0.1-6000.0	10	s	✓	✓	✓	
05-24	Preset Speed 3-Dec time	0.1-6000.0	10	s	✓	✓	✓	
05-25	Preset Speed 4-Acc time	0.1-6000.0	10	s	✓	✓	✓	
05-26	Preset Speed 4-Dec time	0.1-6000.0	10	s	✓	✓	✓	
05-27	Preset Speed 5-Acc time	0.1-6000.0	10	s	✓	✓	✓	
05-28	Preset Speed 5-Dec time	0.1-6000.0	10	s	✓	✓	✓	
05-29	Preset Speed 6-Acc time	0.1-6000.0	10	s	✓	✓	✓	
05-30	Preset Speed 6-Dec time	0.1-6000.0	10	s	✓	✓	✓	
05-31	Preset Speed 7-Acc time	0.1-6000.0	10	s	✓	✓	✓	
05-32	Preset Speed 7-Dec time	0.1-6000.0	10	s	✓	✓	✓	

05-01 to 05-16: If the maximum output frequency of motor is over 300HZ, the frequency resolution is changed to 0.1Hz

*1: Parameter can be changed while running.

Group 05 Preset Frequency Selection								
Param. #	Parameter Name	Setting Range	Default	Unit	Control mode			Notes
					V/F	SLV	PMSLV	
05-33	Preset Speed 8-Acc time	0.1–6000.0	10	s	✓	✓	✓	
05-34	Preset Speed 8-Dec time	0.1–6000.0	10	s	✓	✓	✓	
05-35	Preset Speed 9-Acc time	0.1–6000.0	10	s	✓	✓	✓	
05-36	Preset Speed 9-Dec time	0.1–6000.0	10	s	✓	✓	✓	
05-37	Preset Speed 10-Acc time	0.1–6000.0	10	s	✓	✓	✓	
05-38	Preset Speed 10-Dec time	0.1–6000.0	10	s	✓	✓	✓	
05-39	Preset Speed 11-Acc time	0.1–6000.0	10	s	✓	✓	✓	
05-40	Preset Speed 11-Dec time	0.1–6000.0	10	s	✓	✓	✓	
05-41	Preset Speed 12-Acc time	0.1–6000.0	10	s	✓	✓	✓	
05-42	Preset Speed 12-Dec time	0.1–6000.0	10	s	✓	✓	✓	
05-43	Preset Speed 13-Acc time	0.1–6000.0	10	s	✓	✓	✓	
05-44	Preset Speed 13-Dec time	0.1–6000.0	10	s	✓	✓	✓	
05-45	Preset Speed 14-Acc time	0.1–6000.0	10	s	✓	✓	✓	
05-46	Preset Speed 14-Dec time	0.1–6000.0	10	s	✓	✓	✓	
05-47	Preset Speed 15-Acc time	0.1–6000.0	10	s	✓	✓	✓	
05-48	Preset Speed 15-Dec time	0.1–6000.0	10	s	✓	✓	✓	

Group 06 Automatic Program Operation								
Param. #	Parameter Name	Setting Range	Default	Unit	Control mode			Notes
					V/F	SLV	PMSLV	
06-00	Auto Run Mode Selection	0: Disabled	0	-	✓	✓	X	
		1: Execute a single-cycle operation mode. Restart speed is based on the previous stopped speed.						
		2: Execute continuous-cycle operation mode. Restart speed is based on the previous stopped speed.						
		3: After the completion of a single-cycle, the on-going operation speed is based on the speed of the last stage. Restart speed is based on the previous stopped speed.						
		4: Execute a single-cycle operation mode. Restart speed will be based on the speed of stage 0.						
		5: Execute continuous-cycle operation mode. Restart speed will be based on the speed of stage 0.						
		6: After the completion of a single-cycle, the on-going operation speed is based on the speed of the last stage. Restart speed is based on the speed of stage 0.						
06-01	Frequency Setting Operation-Stage 1	0.00–599.00	0	Hz	✓	✓	X	*1, (Note)
06-02	Frequency Setting Operation-Stage 2	0.00–599.00	0	Hz	✓	✓	X	*1, (Note)
06-03	Frequency Setting Operation-Stage 3	0.00–599.00	0	Hz	✓	✓	X	*1, (Note)

Group 06 Automatic Program Operation								
Param. #	Parameter Name	Setting Range	Default	Unit	Control mode			Notes
					V/F	SLV	PMSLV	
06-04	Frequency Setting Operation-Stage 4	0.00-599.00	0	Hz	✓	✓	X	*1, (Note)
06-05	Frequency Setting Operation-Stage 5	0.00-599.00	0	Hz	✓	✓	X	*1, (Note)
06-06	Frequency Setting Operation-Stage 6	0.00-599.00	0	Hz	✓	✓	X	*1, (Note)
06-07	Frequency Setting Operation-Stage 7	0.00-599.00	0	Hz	✓	✓	X	*1, (Note)
06-08	Frequency Setting Operation-Stage 8	0.00-599.00	0	Hz	✓	✓	X	*1, (Note)
06-09	Frequency Setting Operation-Stage 9	0.00-599.00	0	Hz	✓	✓	X	*1, (Note)
06-10	Frequency Setting Operation-Stage 10	0.00-599.00	0	Hz	✓	✓	X	*1, (Note)
06-11	Frequency Setting Operation-Stage 11	0.00-599.00	0	Hz	✓	✓	X	*1, (Note)
06-12	Frequency Setting Operation-Stage 12	0.00-599.00	0	Hz	✓	✓	X	*1, (Note)
06-13	Frequency Setting Operation-Stage 13	0.00-599.00	0	Hz	✓	✓	X	*1, (Note)
06-14	Frequency Setting Operation-Stage 14	0.00-599.00	0	Hz	✓	✓	X	*1, (Note)
06-15	Frequency Setting Operation-Stage 15	0.00-599.00	0	Hz	✓	✓	X	*1, (Note)
06-16	Operation Time Setting Speed-Stage 0	0.0-6000.0	0	s	✓	✓	X	*1
06-17	Operation Time Setting Speed-Stage 1	0.0-6000.0	0	s	✓	✓	X	*1
06-18	Operation Time Setting Speed-Stage 2	0.0-6000.0	0	s	✓	✓	X	*1
06-19	Operation Time Setting Speed-Stage 3	0.0-6000.0	0	s	✓	✓	X	*1
06-20	Operation Time Setting Speed-Stage 4	0.0-6000.0	0	s	✓	✓	X	*1
06-21	Operation Time Setting Speed-Stage 5	0.0-6000.0	0	s	✓	✓	X	*1
06-22	Operation Time Setting Speed-Stage 6	0.0-6000.0	0	s	✓	✓	X	*1
06-23	Operation Time Setting Speed-Stage 7	0.0-6000.0	0	s	✓	✓	X	*1
06-24	Operation Time Setting Speed-Stage 8	0.0-6000.0	0	s	✓	✓	X	*1
06-25	Operation Time Setting Speed-Stage 9	0.0-6000.0	0	s	✓	✓	X	*1
06-26	Operation Time Setting Speed-Stage 10	0.0-6000.0	0	s	✓	✓	X	*1
06-27	Operation Time Setting Speed-Stage 11	0.0-6000.0	0	s	✓	✓	X	*1
06-28	Operation Time Setting Speed-Stage 12	0.0-6000.0	0	s	✓	✓	X	*1
06-29	Operation Time Setting Speed-Stage 13	0.0-6000.0	0	s	✓	✓	X	*1
06-30	Operation Time Setting Speed-Stage 14	0.0-6000.0	0	s	✓	✓	X	*1
06-31	Operation Time Setting Speed-Stage 15	0.0-6000.0	0	s	✓	✓	X	*1

Group 06 Automatic Program Operation								
Param. #	Parameter Name	Setting Range	Default	Unit	Control mode			Notes
					V/F	SLV	PMSLV	
06-32	Operation Direction Speed Stage 0	0: Stop 1: Forward 2: Reverse	0	-	✓	✓	X	
06-33	Operation Direction Speed Stage 1	0: Stop 1: Forward 2: Reverse	0	-	✓	✓	X	
06-34	Operation Direction Speed Stage 2	0: Stop 1: Forward 2: Reverse	0	-	✓	✓	X	
06-35	Operation Direction Speed Stage 3	0: Stop 1: Forward 2: Reverse	0	-	✓	✓	X	
06-36	Operation Direction Speed Stage 4	0: Stop 1: Forward 2: Reverse	0	-	✓	✓	X	
06-37	Operation Direction Speed Stage 5	0: Stop 1: Forward 2: Reverse	0	-	✓	✓	X	
06-38	Operation Direction Speed Stage 6	0: Stop 1: Forward 2: Reverse	0	-	✓	✓	X	
06-39	Operation Direction Speed Stage 7	0: Stop 1: Forward 2: Reverse	0	-	✓	✓	X	
06-40	Operation Direction Speed Stage 8	0: Stop 1: Forward 2: Reverse	0	-	✓	✓	X	
06-41	Operation Direction Speed Stage 9	0: Stop 1: Forward 2: Reverse	0	-	✓	✓	X	
06-42	Operation Direction Speed Stage 10	0: Stop 1: Forward 2: Reverse	0	-	✓	✓	X	
06-43	Operation Direction Speed Stage 11	0: Stop 1: Forward 2: Reverse	0	-	✓	✓	X	
06-44	Operation Direction Speed Stage 12	0: Stop 1: Forward 2: Reverse	0	-	✓	✓	X	
06-45	Operation Direction Speed Stage 13	0: Stop 1: Forward 2: Reverse	0	-	✓	✓	X	
06-46	Operation Direction Speed Stage 14	0: Stop 1: Forward 2: Reverse	0	-	✓	✓	X	
06-47	Operation Direction Speed Stage 15	0: Stop 1: Forward 2: Reverse	0	-	✓	✓	X	

06-01 to 06-15: If the maximum output frequency of motor is over 300HZ, the frequency resolution is changed to 0.1Hz

*1: Parameter can be changed while running.

Group 07 Start/Stop Parameters								
Param. #	Parameter Name	Setting Range	Default	Unit	Control mode			Notes
					V/F	SLV	PMSLV	
07-00	Momentary Power Loss and Restart	0: Disable	0	-	✓	✓	X	
		1: Enable						
07-01	Fault Reset Time	0–7200	0	s	✓	✓	✓	
07-02	Number of Auto Restart Attempts	0–10	0	-	✓	✓	✓	
07-03	Reset Mode Setting	0: Enable Reset Only when Run Command is Off 1: Enable Reset when Run Command is On or Off	0	-	✓	✓	✓	
07-04	Direct Stop at Power On	0: Enable Direct run on power up	1	-	✓	✓	✓	
		1: Disable Direct run on power up						
07-05	Direct Start Delay	1.0–300.0	1	s	✓	✓	✓	
07-06	DC Injection Braking Start Frequency	0.0–10.0	1.5	Hz	✓	✓	✓	
07-07	DC Injection Braking Level (Current Mode)	0–100	50	%	✓	✓	✓	
07-08	DC Injection Braking Time	0.0–25.5	0.5	s	✓	✓	✓	
07-09	Stop Mode Selection	0: Deceleration to Stop	0	-	✓	✓	✓	
		1: Coast to Stop						
		2: DC Braking Stop in All Fields						
		3: Coast to Stop with Timer						
07-10	Speed Search Mode Selection	0: Normal Start	0	-	✓	✓	X	
		1: Execute Speed Search Once						
		2: Speed Search Start						
07-11	DC Injection Braking Start Time	0.00–100.00	0.00	s	✓	✓	✓	
07-13	Low Voltage Detection Level	240V: 150–300	190	V	✓	✓	✓	
		480V: 250–600	380					
07-15	DC Injection Brake Mode	0: Voltage Mode 1: Current Mode	1		✓	✓	X	
07-18	Minimum Base block Time	0.1–5.0	0.5	Sec	✓	✓	✓	
07-19	Speed Direction Search Operation Current	0–100	50	%	✓	✓	X	
07-20	Speed Search Operating Current	0–100	20	%	✓	✓	X	
07-21	Speed Searching Integral Time	0.1–10.0	2	Sec	✓	✓	X	
07-22	Speed Searching Delay Time	0.0–20.0	0.2	Sec	✓	✓	X	
07-23	Voltage Recovery Time	0.1–5.0	2	Sec	✓	✓	X	
07-24	Direction-Detection Speed Search Selection	0: Invalid	1	-	✓	✓	X	
		1: Valid						

Group 07 Start/Stop Parameters								
Param. #	Parameter Name	Setting Range	Default	Unit	Control mode			Notes
					V/F	SLV	PMSLV	
07-25	Low Voltage Detection Time	0.00–1.00	0.02	Sec	✓	✓	✓	
07-26	SLV Coast to Stop Start-up Mode Selection	0: Start With Speed Search 1: Normal Start	0	-	X	✓	X	
07-27	Start after Fault During SLV Mode	0: Start With Speed Search 1: Normal Start	0	-	X	✓	X	
07-28	Start after External BaseBlock	0: Start With Speed Search 1: Normal Start	0	-	✓	✓	X	
07-29	Run Command at Action of DC Braking	0: Not Allowable to Run 1: Allowable to Run	0	-	✓	X	X	
07-33	Speed Search Start Frequency	0: Maximum Output Frequency 1: Frequency Command	0	-	✓	✓	X	
07-34	Start Short-Circuit Braking Time	0.00–100.00	0	Sec	X	X	✓	
07-35	Stop Short-Circuit Braking Time	0.00–100.00	0.5	Sec	X	X	✓	
07-36	Short-Circuit Braking Current Limited	0.0–200.0	100	%	X	X	✓	
07-37	Pre-Excitation Time	0.00–10.00	2	Sec	X	✓	X	
07-38	Pre-Excitation Level	50–200	100	%	X	✓	X	
07-39	PM Motor Speed Search Function Short-Circuit Braking Time	0.00–100.00	0	Sec	X	X	✓	
07-40	PM Motor Speed Search Function DC Injection Braking Time	0.00–100.00	0	Sec	X	X	✓	
07-45	Terminal Stop Display	0: Enabled 1: Disabled	0	-	✓	✓	✓	

Group 08 Protection Parameters								
Param. #	Parameter Name	Setting Range	Default	Unit	Control mode			Notes
					V/F	SLV	PMSLV	
08-00	Stall Prevention Function	xxx0b: Stall prevention is enabled in acceleration. xxx1b: Stall prevention is disabled in acceleration. xx0xb: Stall prevention is enabled in deceleration. xx1xb: Stall prevention is disabled in deceleration. x0xxb: Stall prevention is enabled in operation x1xxb: Stall prevention is disabled in operation 0xxxb: Stall prevention in operation is based on deceleration time of speed-stage 1. 1xxxb: Stall prevention in operation is based on deceleration time of speed-stage 2.	0000b	-	✓	✓	✓	
08-01	Stall Prevention Level During Acceleration	20–200	HD: 150 ND: 120	%	✓	✓	✓	
08-02	Stall Prevention Level During Deceleration	240V: 330V–410V 480V: 660V–820V	385V 770V	V	✓	✓	✓	
08-03	Stall Prevention Level During Run	30–200	HD: 160 ND: 120	%	✓	X	X	

Group 08 Protection Parameters								
Param. #	Parameter Name	Setting Range	Default	Unit	Control mode			Notes
					V/F	SLV	PM	
08-05	Motor Overload Protection (OL1)	xxx0b: Overload Protection is disabled.	V/F & SLV: 0001b PMSLV: 0101b	-	✓	✓	✓	
		xxx1b: Overload Protection is enabled.						
		xx0xb: Cold Start of Motor Overload						
		xx1xb: Hot Start of Motor Overload						
		x0xxb: Standard Motor						
		x1xxb: AC Drive Duty Motor						
		0xxxb: Reserved						
		1xxxb: Reserved						
08-06	Start-up Mode of Overload Protection Operation (OL1)	0: Stop Output after Overload Protection	0	-	✓	✓	✓	
		1: Continuous Operation after Overload Protection.						
08-07	Overheat Protection (Cooling Fan Control)	0: Auto (Depends on temp.)	1	-	✓	✓	✓	
		1: Operate while in RUN Mode						
		2: Always Run						
		3: Stop Operation						
08-08	Auto Voltage Regulation (AVR)	0: Enable	0	-	✓	✓	✓	
		1: Disable						
08-09	Input Phase Loss Protection	0: Disable 1: Enable	0	-	✓	✓	✓	
08-10	Output Phase Loss Protection	0: Disable 1: Enable	0	-	✓	✓	✓	
08-13	Over-Torque Detection	0: Over-Torque Detection is Disabled.	0	-	✓	✓	✓	
		1: Start detection when reaching the set frequency.						
		2: Start detection during running						
08-14	Over-Torque Action	0: Decelerate to Stop when Over Torque is Detected.	0	-	✓	✓	✓	
		1: Display Warning when Over Torque is Detected. Continue operation.						
		2: Coast to Stop when Over Torque is Detected						
08-15	Level of Over-Torque Detection	0–300	160	%	✓	✓	✓	
08-16	Time of Over-Torque Detection	0.0–10.0	0.1	Sec	✓	✓	✓	
08-21	Limit of Stall Prevention During Acceleration	1–100	50	%	✓	✓	✓	
08-22	Stall Prevention Detection Time During Run	2–100	100	ms	✓	✓	✓	
08-23	Ground Fault (GF) Selection	0: Disable 1: Enable	0	-	✓	✓	✓	
08-24	External Fault Operation	0: Deceleration to Stop 1: Coast to Stop 2: Continuous Operation	0	-	✓	✓	✓	
08-25	External Fault Detection	0: Immediately Detect when power is supplied 1: Start to Detect during Operation	0	-	✓	✓	✓	
08-35	Motor Overheating Fault Selection	0: Disable	0	-	✓	✓	✓	
		1: Deceleration to Stop						
		2: Coast to Stop						
		3: Continue Running						

Group 08 Protection Parameters								
Param. #	Parameter Name	Setting Range	Default	Unit	Control mode			Notes
					V/F	SLV	PMSLV	
08-36	PTC Input Filter Time Constant	0.00 – 5.00	2	Sec	✓	✓	✓	
08-38	Delay Time Fan Off	0–600	60	Sec	✓	✓	✓	
08-39	Delay Time Motor Overheat Protection	1–300	60	Sec	✓	✓	✓	
08-40	Motor2 Acceleration Stall Prevention Level	1–100	HD: 150	%	✓	X	X	
			ND: 120					
08-41	Motor2 Acceleration Stall Prevention Limit	1–100	50	%	✓	X	X	
08-42	PTC Protection Level	0.1–10.0V	0.7	V	✓	✓	✓	
08-43	PTC Restart Level	0.1–10.0V	0.3	V	✓	✓	✓	
08-44	PTC Warning Level	0.1–10.0V	0.5	V	✓	✓	✓	
08-46	Temperature Agree Level	0–254	0	°C	✓	✓	✓	
08-47	Temperature Reset Level	0–254	0	°C	✓	✓	✓	
08-48	Fire Mode	0: Disable 1: Enable	0	-	✓	✓	✓	
08-49	Fire Mode Multi-function Input Terminal Status	0: Reset after Power Off 1: Reset after Terminal Removed	0	-	✓	✓	✓	
08-50	Input Terminal Type	xxx0b: S6 A Contact xxx1b: S6 B Contact	0000b	-	✓	✓	✓	
08-51	Fire Mode Motor Speed Source	0: Fire Mode Speed (08-52) 1: PID Control 2: AI2	0	-	✓	✓	✓	
08-52	Fire Mode Motor Speed	0.00–100.00	100.00	%	✓	✓	✓	
08-53	Fire Mode PID Feedback Loss Detection Level	0–100	0	-	✓	✓	✓	
08-54	Fire Mode PID Feedback Loss Detection Time	0.0–10.0	1.0	-	✓	✓	✓	
08-55	Fire Mode PID Feedback Loss Detection Action	0: Keep Running 1: Fire Mode Speed (08-52) 2: Max. Output Frequency of Motor 1 (01-02)	1	-	✓	✓	✓	
08-56	Fire Mode AI2 Signal Loss Detection Level	0–100	80	%	✓	✓	✓	
08-57	Fire Mode AI2 Signal Loss Detection Time	0.0–10.0	1.0	s	✓	✓	✓	
08-58	Fire Mode AI2 Signal Loss Detection Action	0: Keep Running 1: Fire Mode Speed (08-52) 2: Max. Output Frequency (01-02)	1	-	✓	✓	✓	
08-59	Fire Mode Motor Direction	0: Forward 1: Reverse	0	-	✓	✓	✓	
08-60	Fire Mode Password	00000–65534	00000	-	✓	✓	✓	

08-53 to 08-58: Only accessible after enabling Fire Mode in parameter 08-48.

Group 09 Communication Parameters								
Param. #	Parameter Name	Setting Range	Default	Unit	Control mode			Notes
					V/F	SLV	PMSLV	
09-00	Communication Station Address	1–254	1	-	✓	✓	✓	*3, (note)
09-01	Communication Mode Selection	0: MODBUS	0	-	✓	✓	✓	*3,*5, (note)
		2: BACnet						
09-02	Baud Rate Setting (bps)	0: 4800	2	-	✓	✓	✓	*3, (note)
		1: 9600						
		2: 19200						
		3: 38400						
09-03	Stop Bit Selection	0: 1 Stop Bit	0	-	✓	✓	✓	*3, (note)
		1: 2 Stop Bit						
09-04	Parity Selection	0: No Parity	0	-	✓	✓	✓	*3, (note)
		1: Even Bit						
		2: Odd Bit						
09-05	Communication Data Bit Selection	0: 8 Bit Data	0	-	✓	✓	✓	*3, (note)
		1: 7 Bit Data						
09-06	Communication Error Detection Time	0.0–25.5	0	S	✓	✓	✓	*3, (note)
09-07	Fault Stop Selection	0: Deceleration to stop based on deceleration time 1	3	-	✓	✓	✓	*3, (note)
		1: Coast to Stop during comm. fault						
		2: Deceleration to stop based on deceleration Time 2						
		3: Continue Operation						
09-08	Communication Error Threshold	0–20	1	-	✓	✓	✓	*3, (note)
09-09	Waiting Time	5–65	5	ms	✓	✓	✓	*3, (note)
09-10	BACNET Device Instance Number	1–254	1	-	✓	✓	✓	

09-00 to 09-10: Changes to group 09 require power cycling the AC drive to take effect.

***3:** Parameter will not be reset to default during a factory reset (initialization)

***5:** Parameter will be displayed when option card is installed.

Group 10 PID Parameters								
Param. #	Parameters	Setting Range	Default	Unit	Control Mode			Notes
					V/F	SLV	PMSLV	
10-00	PID Target Value Source Setting	0: Keypad Potentiometer 1: AI1 Input 2: AI2 Input 3: Communication 4: Target Source set by 10-02	1	-	✓	✓	✓	
10-01	PID Feedback Value Source Setting	0: Keypad Potentiometer 1: AI1 Input 2: AI2 Input 3: Communication	2	-	✓	✓	✓	
10-02	PID Target Value	0.00–100.00	0	%	✓	✓	✓	*1
10-03	PID Control Mode	xxx0b: PID Disable	0000b	-	✓	✓	✓	
		xxx1b: PID Enable						
		xx0xb: PID Positive Characteristic						
		xx1xb: PID Negative Characteristic						
		x0xxb: PID Error Value of D Control						
		x1xxb: PID Feedback Value of D Control						
		0xxxb: PID Output						
1xxxb: PID Output+Frequency Command								
10-04	Feedback Gain	0.01–10.00	1	-	✓	✓	✓	*1
10-05	Proportional Gain (P)	0.0–10.00	1	-	✓	✓	✓	*1
10-06	Integral Time (I)	0.00–100.00	1	s	✓	✓	✓	*1
10-07	Differential Time (D)	0.00–10.00	0	s	✓	✓	✓	*1
10-08	PID Offset	0: Positive 1: Negative	0	-	✓	✓	✓	
10-09	PID Bias	0–109	0	%	✓	✓	✓	*1
10-11	PID Feedback Loss Detection Selection	0: Disable 1: Warning 2: Fault	0	-	✓	✓	✓	*1
10-12	PID Feedback Loss Detection Level	0–100	0	%	✓	✓	✓	
10-13	PID Feedback Loss Detection Delay Time	0.0–25.5	1	s	✓	✓	✓	
10-14	PID Integral Limit	0.0–100.0	100	%	✓	✓	✓	*1
10-15	PID Integrator Reset Delay	0–30	0	s	✓	✓	✓	
10-16	PID Integrator Reset Deviation Range	0–100	0	%	✓	✓	✓	
10-17	PID Sleep Start Freq.	0.00–599.00	0	Hz	✓	✓	✓	(Note)
10-18	PID Sleep Start Delay	0.0–255.5	0	s	✓	✓	✓	
10-19	PID Sleep Stop Freq.	0.00–599.00	0	Hz	✓	✓	✓	(Note)
10-20	PID Sleep Stop Delay	0.0–25.5	0	s	✓	✓	✓	
10-23	PID Limit	0.0–100.0	100	%	✓	✓	✓	*1
10-24	PID Output Gain	0.0–25.0	1	-	✓	✓	✓	
10-25	PID Reversal Output Selection	0: Don't Allow Reversal Output 1: Allow Reversal Output	0	-	✓	✓	✓	
10-26	PID Target Acceleration/Deceleration Time	0.0–25.5	0	s	✓	✓	✓	
10-27	PID Feedback Display Bias	0 – 9999	0	-	✓	✓	✓	

Group 10 PID Parameters								
Param. #	Parameters	Setting Range	Default	Unit	Control Mode			Notes
					V/F	SLV	PMSLV	
10-29	PID Sleep Selection	0: Disable	1	-	✓	✓	✓	
		1: Enable						
		2: Set By DI						
10-30	Upper Limit PID Target	0.0 – 100.0	100	%	✓	✓	✓	
10-31	Lower Limit PID Target	0.0 – 100.0	0	%	✓	✓	✓	
10-33	Maximum Value of PID Feedback	1 – 10000	999	-	✓	✓	✓	
10-34	PID Value Scaling	0 – 4	1		✓	✓	✓	
10-35	PID Unit	0: % 1: FPM 2: CFM 3: PSI 4: GPH 5: GPM 6: IN 7: FT 8: /s 9: /m 10: /h 11: °F 12: inW 13: HP 14: m/s 15: MPM 16: CMM 17: W 18: KW 19: m 20: °C 21: RPM 22: Bar 23: Pa 24: kPa	0		✓	✓	✓	*7
10-39	PID Disconnection Output Frequency	00.00–599.00	30	Hz	✓	✓	✓	(Note)
10-40	PID Sleep Compensation Frequency	0: Disable 1: Enable	0	-	✓	✓	✓	
10-41	Differential Mode Enable	0: Disable 1: Differential PID Mode	0	-	✓	✓	✓	
10-47	Fire Mode Proportional Gain (P)	0.00–10.00	1.00	-	✓	✓	✓	
10-48	Fire Mode Integral Time (I)	0.00–100.00	1.00	s	✓	✓	✓	
10-49	Fire Mode Differential Time (D)	0.00–10.00	0.00	s	✓	✓	✓	(Note)
10-50	Derivative Filter	1–250	4	-	✓	✓	✓	
10-51	PID Integrator Tolerance	0 – 100	0	%	✓	✓	✓	
10-52	Accumulator Reset Mode	0 – 30	0	-	✓	✓	✓	

10-17 and 10-19: Must set 01-02 first.

10-17, 10-19, 10-39: If max. output frequency of motor is over 300HZ, the frequency resolution is changed to 0.1Hz

10-49: Fire Mode must be enabled with 08-48 first.

*1: Parameter can be changed while running

*7: Parameter will be displayed only when using the LCD keypad.

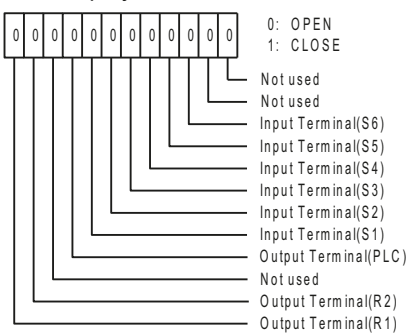
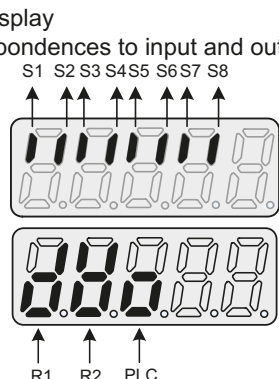
Group 11 Auxiliary Parameters								
Param. #	Parameters	Setting Range	Default	Unit	Control Mode			Notes
					V/F	SLV	PMSLV	
11-00	Direction Lock Selection	0: Allow For. and Rev. Rotation	0	-	✓	✓	✓	
		1: Only Allow Forward Rotation						
		2: Only Allow Reverse Rotation						
11-01	Carrier frequency	0: Carrier Output Frequency Tuning	5	-	✓	✓	✓	*1, (note)
		1-16: 1-16KHz						
11-02	Software PWM Function Selection	0: Disable + 3 phase PWM modulation	0	-	✓	✓	✓	
		1: Enable + 2 phase PWM modulation						
11-03	Automatic carrier lowering	0: Disable	0	-	✓	X	X	
		1: Enable						
11-04	S-Curve Acceleration Start Time	0.00-2.50	0.2	s	✓	✓	✓	
11-05	S-Curve Acceleration Stop Time	0.00-2.50	0.2	s	✓	✓	✓	
11-06	S-Curve Deceleration Start Time	0.00-2.50	0.2	s	✓	✓	✓	
11-07	S-Curve Deceleration Stop Time	0.00-2.50	0.2	s	✓	✓	✓	
11-08	Jump Frequency 1	0.0-599.0	0	Hz	✓	✓	✓	(note)
11-09	Jump Frequency 2	0.0-599.0	0	Hz	✓	✓	✓	(note)
11-10	Jump Frequency 3	0.0-599.0	0	Hz	✓	✓	✓	(note)
11-11	Jump Frequency Width	0.0 - 25.5	1	Hz	✓	✓	✓	
11-12	Manual Energy Saving Gain (V/F)	0-100	80	%	✓	X	X	
11-13	OV Prevention Selection	0: Disable 1: OV Prevention Mode 1 2: OV Prevention Mode 2 3: OV Prevention Mode 3	0	-	✓	X	X	
11-14	OV Prevention Level	240V: 200V-400V	370	V	✓	X	X	
		480V: 400V-800V	740					
11-17	Accel. / Decel. Gain	0.1-10.0	1	-	✓	X	X	
11-18	Manual Energy Savings Frequency	0.0-599.0	0	Hz	✓	X	X	
11-19	Automatic Energy Saving Function	0: Automatic energy saving is disabled 1: Automatic energy saving is enabled	0	-	✓	X	X	
11-20	Automatic Energy Saving Filter Time	0-200	140	ms	✓	X	X	
11-21	Energy Saving Tune Voltage Upper Limit	0-100	100	%	✓	X	X	
11-22	Auto Energy Saving Adjustment Time	0-5000	20	ms	✓	X	X	
11-23	Auto Energy Saving Detection Level	0-100	10	%	✓	X	X	
11-24	Automatic Energy Saving Coefficient	0.00-655.34	-	-	✓	X	X	
11-28	Frequency Gain Over Voltage Prevention 2	1 - 200	100	%	✓	X	X	
11-33	DC Voltage Filter Rise Amount	0.1 - 10.0	0.1	V	✓	X	X	
11-34	DC Voltage Filter Fall Amount	0.1 - 10.0	5.0	V	✓	X	X	
11-35	DC Voltage Filter Dead-band Level	0.0 - 99.0	10.0	V	✓	X	X	
11-36	OV Prevention Frequency Gain	0.000 - 1.000	0.050	-	✓	X	X	

Group 11 Auxiliary Parameters								
Param. #	Parameters	Setting Range	Default	Unit	Control Mode			Notes
					V/F	SLV	PMSLV	
11-37	OV Prevention Frequency Limit	0.00 – 599.00	5.00	Hz	✓	X	X	
11-38	OV Prevention Decel. Start Voltage	240V: 240V–400V	300	V	✓	X	X	
		480V: 400V–800V	600					
11-39	OV Prevention Decel. End Voltage	240V: 300V–400V	350	V	✓	X	X	
		480V: 600V–800V	700					
11-41	Reference Frequency Disappearance Detection	0: Decelerate to Stop when Reference Frequency Disappears 1: Operation is set by Parameter 11-42 when Reference Frequency Disappears	0	-	✓	✓	✓	
11-42	Reference Frequency Disappearance Level	0.0–100.0	80.0	%	✓	✓	✓	
11-43	Hold Frequency at Start	0.0–599.0	0.0	Hz	✓	✓	✓	
11-44	Frequency Hold Time at Start	0.0–10.0	0.0	s	✓	✓	✓	
11-45	Hold Frequency at Stop	0.0–599.0	0.0	Hz	✓	✓	✓	
11-46	Frequency Hold Time at Stop	0.0–10.0	0.0	s	✓	✓	✓	
11-47	KEB Deceleration Time	0.0–25	0	s	✓	X	X	
11-48	KEB Detection Level	240V: 190–210	200V	V	✓	X	X	
		480V: 380–420	400V					
11-55	STOP Key Selection	0: Stop Key is Disabled when the Operation Command is not Provided by Operator.	1	-	✓	✓	✓	
		1: Stop Key is Enabled when the Operation Command is not Provided by Operator.						
11-59	Oscillation Prevention Gain 1	0.00–2.50	0.00	-	✓	X	X	(note)
11-60	Upper Limit of Oscillation Prevention 1	1–100	100	%	✓	X	X	(note)
11-61	Time Parameter of Oscillation Prevention 1	0–100	0	-	✓	X	X	
11-62	Oscillation Prevention	0: Mode 1	1	-	✓	X	X	
		1: Mode 2						
		2: Mode 3						
11-63	Strong Magnetic Selection	0: Disable	1	-	X	✓	X	
		1: Enable						
11-66	2/3 Phase Soft. Switch Frequency	6.00–60.00	20	-	X	✓	X	
11-67	Soft. PWM Freq. Bias	0–12000	0	-	X	✓	X	
11-68	Soft. PWM Switch Freq.	6.00–60.00	20	Hz	X	✓	X	
11-69	Oscillation Prevention Gain 2	0.00–200.00	5	%	✓	X	X	
11-70	Upper Limit of Oscillation Prevention 2	0.01–100.00	5	%	✓	X	X	
11-71	Time Parameter of Oscillation Prevention 2	0–30000	100	ms	✓	X	X	
11-72	Switch Frequency 1 Oscillation Prevention 2	0.01–300.00	30	Hz	✓	X	X	
11-73	Switch Frequency 2 Oscillation Prevention 2	0.01–300.00	50	Hz	✓	X	X	

11-08 to 11-10: Range is dependent on parameter 01-02

11-01, 11-59, 11-60: If the maximum output frequency of motor is over 300HZ, frequency resolution is changed to 0.1Hz

*1: Parameter can be changed while running

Group 12 Monitoring Parameters								
Param. #	Parameters	Setting Range	Default	Unit	Control Mode			Notes
					V/F	SLV	PMSLV	
12-00	Display Screen (LED)	00000–88888 From the leftmost bit, sets the display sequence when pressing the MODE/PROG key. 0: no display 1: Output Current 2: Output Voltage 3: DC Bus Voltage 4: Heatsink Temperature* 5: PID Feedback 6: AI1 Value 7: AI2 Value 8: Counter Value	321	-	✓	✓	✓	*1 *6
12-01	PID Feedback Display Mode (LED)	0: Display the Feedback Value by Integer (xxx)	0	-	✓	✓	✓	*6
		1: Display the Feedback Value by the Value with One Decimal Place (xx.x)						
		2: Display the Feedback Value by the Value with Two Decimal Places (x.xx)						
12-02	PID Feedback Display Unit Setting (LED)	0: xxxxx (no unit)	0	-	✓	✓	✓	*6
		1: xxxPb (pressure)						
		2: xxxFL (flow)						
12-03	Line Speed Display (LED)	0–60000	1500 / 1800	RPM	✓	✓	✓	*1 *6
12-04	Modes of Line Speed Display (LED)	0: Display AC Drive Output Frequency	0	-	✓	✓	✓	*1 *6
		1: Display Line Speed as integer (xxxxx)						
		2: Display Line Speed with the First Decimal Place (xxxx.x)						
		3: Display Line Speed with the Second Decimal Place (xxx.xx)						
		4: Display Line Speed with the Third Decimal Place (xx.xxx)						
12-05	Status Display of Digital Input & Output Terminal (LED/LCD)	LCD display 	-	-	✓	✓	✓	*9
		LED Display Correspondences to input and output 						

Group 12 Monitoring Parameters								
Param. #	Parameters	Setting Range	Default	Unit	Control Mode			Notes
					V/F	SLV	PMSLV	
12-06	Output Current	Display the present output current	-	A	✓	✓	✓	*4
12-07	Output Power	Display the present output power	-	W	✓	✓	✓	*4
12-11	Output Current of Current Fault at Trip	Display the output current of current fault	-	A	✓	✓	✓	*4
12-12	Output Voltage of Current Fault at Trip	Display the output voltage of current fault	-	V	✓	✓	✓	*4
12-13	Output Frequency of Current Fault at Trip	Display the output frequency of current fault	-	Hz	✓	✓	✓	*4
12-14	DC Voltage of Current Fault at Trip	Display the DC voltage of current fault	-	V	✓	✓	✓	*4
12-15	Frequency Command of Current Fault at Trip	Display the frequency command of current fault	-	Hz	✓	✓	✓	*4
12-16	Frequency Command	If LED enters this parameter, it only allows monitoring frequency command.	-	Hz	✓	✓	✓	*4
12-17	Output Frequency	Display the current output frequency	-	Hz	✓	✓	✓	*4
12-19	Output Voltage	Display the current output voltage	-	V	✓	✓	✓	*4
12-20	DC Voltage (Vdc)	Display the current DC voltage	-	V	✓	✓	✓	*4
12-28	Motor Torque Current (Iq)	Display the current q-axis current	-	A	X	✓	✓	*4
12-29	Motor Excitation Current (Id)	Display the current d-axis current	-	A	X	✓	✓	*4
12-36	PID Input	Display input error of the PID controller (PID target value - PID feedback) (100% corresponds to the maximum frequency set by 01-02 or 01-16)	-	%	✓	✓	✓	*4
12-37	PID Output	Display output of the PID controller (100% corresponds to the maximum frequency set by 01-02 or 01-16)	-	%	✓	✓	✓	*4
12-38	PID Setting	Display the target value of the PID controller (100% corresponds to the maximum frequency set by 01-02 or 01-16)	-	%	✓	✓	✓	*4
12-39	PID Feedback	Display the feedback value of the PID controller (100% corresponds to the maximum frequency set by 01-02 or 01-16)	-	%	✓	✓	✓	*4
12-41	Heatsink Temperature	Display the heatsink temperature / IGBT temperature`	-	°C	✓	✓	✓	*4
12-43	AC Drive Status		-	-	✓	✓	✓	(note)
12-74	Reserved	-	-	-	-	-	-	
12-75	Reserved	-	-	-	-	-	-	
12-82	Motor Load	Display the present motor load	-	%	✓	✓	✓	*4

12-43: Parameter value is displayed in binary

*1: Parameter can be changed while running.

*4: Read-only Parameter

*6: Parameter will be displayed only when using the LED keypad

*9: Parameter will be displayed when using either LED or LCD keypad

Group 13 Maintenance Parameters								
Param. #	Parameters	Setting Range	Default	Unit	Control Mode			Notes
					V/F	SLV	PMSLV	
13-00	AC Drive Capacity	----	Per Model	-	✓	✓	✓	*4,*9
13-01	Software Version	----	Per Model	-	✓	✓	✓	*4,*9
13-02	Fault Record	----	0	-	✓	✓	✓	*1
13-03	Hour Meter 1	0–23	Per Model	hr	✓	✓	✓	*4,*9
13-04	Hour Meter 2	0–65534	Per Model	day	✓	✓	✓	*4,*9
13-05	Cumulative Operation Time	0: Cumulative time in power on 1: Cumulative time in operation	0	-	✓	✓	✓	*1
13-06	Parameters Locked	0: Parameters are read-only except 13-06 and main frequency 1: Reserved 2: Advanced Level, all parameters are accessible	2	-	✓	✓	✓	*1
13-07	Parameter Password Function	00000–65534	0	-	✓	✓	✓	*1
13-08	Restore Factory Setting	1: 2 wire initialization (50Hz) (220V/380V) 2: 2 wire initialization (60Hz) (220V/380V) 3: 2 wire initialization (50Hz) (240V/480V) 4: 2 wire initialization (60Hz) (240V/480V) 5: 2 wire initialization (50Hz) (220V/415V) 6: 2 wire initialization (60Hz) (230V/400V) 7: 2 wire initialization (50Hz) (220V/440V) 8: 2 wire initialization (60Hz) (220V/440V) 1112: PLC initialization (RESET)	Per Model	-	✓	✓	✓	*9
13-10	Parameter Password Function 2	0–9999	0	-	✓	✓	✓	
13-51	Hour Meter Reset	0: Do not reset operation time 1: Reset operation time	0	-	✓	✓	✓	

*1: Parameter can be changed while running.

*4: Read-only parameter.

*9: Parameter default setting is dependent on drive size/model.

Group 14 PLC Setting Parameters								
Param. #	Parameters	Setting Range	Default	Unit	Control Mode			Notes
					V/F	SLV	PMSLV	
14-00	T1 Set Value 1	0–9999	0	-	✓	✓	✓	
14-01	T1 Set Value 2 (Mode 7)	0–9999	0	-	✓	✓	✓	
14-02	T2 Set Value 1	0–9999	0	-	✓	✓	✓	
14-03	T2 Set Value 2 (Mode 7)	0–9999	0	-	✓	✓	✓	
14-04	T3 Set Value 1	0–9999	0	-	✓	✓	✓	
14-05	T3 Set Value 2 (Mode 7)	0–9999	0	-	✓	✓	✓	
14-06	T4 Set Value 1	0–9999	0	-	✓	✓	✓	
14-07	T4 Set Value 2 (Mode 7)	0–9999	0	-	✓	✓	✓	

Group 14 PLC Setting Parameters

Param. #	Parameters	Setting Range	Default	Unit	Control Mode			Notes
					V/F	SLV	PMSLV	
14-08	T5 Set Value 1	0-9999	0	-	✓	✓	✓	
14-09	T5 Set Value 2 (Mode 7)	0-9999	0	-	✓	✓	✓	
14-10	T6 Set Value 1	0-9999	0	-	✓	✓	✓	
14-11	T6 Set Value 2 (Mode 7)	0-9999	0	-	✓	✓	✓	
14-12	T7 Set Value 1	0-9999	0	-	✓	✓	✓	
14-13	T7 Set Value 2 (Mode 7)	0-9999	0	-	✓	✓	✓	
14-14	T8 Set Value 1	0-9999	0	-	✓	✓	✓	
14-15	T8 Set Value 2 (Mode 7)	0-9999	0	-	✓	✓	✓	
14-16	C1 Set Value	0-65534	0	-	✓	✓	✓	
14-17	C2 Set Value	0-65534	0	-	✓	✓	✓	
14-18	C3 Set Value	0-65534	0	-	✓	✓	✓	
14-19	C4 Set Value	0-65534	0	-	✓	✓	✓	
14-20	C5 Set Value	0-65534	0	-	✓	✓	✓	
14-21	C6 Set Value	0-65534	0	-	✓	✓	✓	
14-22	C7 Set Value	0-65534	0	-	✓	✓	✓	
14-23	C8 Set Value	0-65534	0	-	✓	✓	✓	
14-24	AS1 Set Value 1	0-65534	0	-	✓	✓	✓	
14-25	AS1 Set Value 2	0-65534	0	-	✓	✓	✓	
14-26	AS1 Set Value 3	0-65534	0	-	✓	✓	✓	
14-27	AS2 Set Value 1	0-65534	0	-	✓	✓	✓	
14-28	AS2 Set Value 2	0-65534	0	-	✓	✓	✓	
14-29	AS2 Set Value 3	0-65534	0	-	✓	✓	✓	
14-30	AS3 Set Value 1	0-65534	0	-	✓	✓	✓	
14-31	AS3 Set Value 2	0-65534	0	-	✓	✓	✓	
14-32	AS3 Set Value 3	0-65534	0	-	✓	✓	✓	
14-33	AS4 Set Value 1	0-65534	0	-	✓	✓	✓	
14-34	AS4 Set Value 2	0-65534	0	-	✓	✓	✓	
14-35	AS4 Set Value 3	0-65534	0	-	✓	✓	✓	
14-36	MD1 Set Value 1	0-65534	1	-	✓	✓	✓	
14-37	MD1 Set Value 2	0-65534	1	-	✓	✓	✓	
14-38	MD1 Set Value 3	0-65534	1	-	✓	✓	✓	
14-39	MD2 Set Value 1	0-65534	1	-	✓	✓	✓	
14-40	MD2 Set Value 2	0-65534	1	-	✓	✓	✓	
14-41	MD2 Set Value 3	0-65534	1	-	✓	✓	✓	
14-42	MD3 Set Value 1	0-65534	1	-	✓	✓	✓	
14-43	MD3 Set Value 2	0-65534	1	-	✓	✓	✓	
14-44	MD3 Set Value 3	0-65534	1	-	✓	✓	✓	
14-45	MD4 Set Value 1	0-65534	1	-	✓	✓	✓	
14-46	MD4 Set Value 2	0-65534	1	-	✓	✓	✓	
14-47	MD4 Set Value 3	0-65534	1	-	✓	✓	✓	

Group 15 PLC Monitoring Parameters								
Param. #	Parameters	Setting Range	Default	Unit	Control Mode			Notes
					V/F	SLV	PMSLV	
15-00	T1 Current Value1	0-9999	0	-	✓	✓	✓	
15-01	T1 Current Value 2 (Mode7)	0-9999	0	-	✓	✓	✓	
15-02	T2 Current Value 1	0-9999	0	-	✓	✓	✓	
15-03	T2 Current Value 2 (Mode7)	0-9999	0	-	✓	✓	✓	
15-04	T3 Current Value 1	0-9999	0	-	✓	✓	✓	
15-05	T3 Current Value 2 (Mode7)	0-9999	0	-	✓	✓	✓	
15-06	T4 Current Value 1	0-9999	0	-	✓	✓	✓	
15-07	T4 Current Value 2 (Mode7)	0-9999	0	-	✓	✓	✓	
15-08	T5 Current Value 1	0-9999	0	-	✓	✓	✓	
15-09	T5 Current Value 2 (Mode7)	0-9999	0	-	✓	✓	✓	
15-10	T6 Current Value 1	0-9999	0	-	✓	✓	✓	
15-11	T6 Current Value 2 (Mode7)	0-9999	0	-	✓	✓	✓	
15-12	T7 Current Value 1	0-9999	0	-	✓	✓	✓	
15-13	T7 Current Value 2 (Mode7)	0-9999	0	-	✓	✓	✓	
15-14	T8 Current Value 1	0-9999	0	-	✓	✓	✓	
15-15	T8 Current Value 2 (Mode7)	0-9999	0	-	✓	✓	✓	
15-16	C1 Current Value	0-65535	0	-	✓	✓	✓	
15-17	C2 Current Value	0-65535	0	-	✓	✓	✓	
15-18	C3 Current Value	0-65535	0	-	✓	✓	✓	
15-19	C4 Current Value	0-65535	0	-	✓	✓	✓	
15-20	C5 Current Value	0-65535	0	-	✓	✓	✓	
15-21	C6 Current Value	0-65535	0	-	✓	✓	✓	
15-22	C7 Current Value	0-65535	0	-	✓	✓	✓	
15-23	C8 Current Value	0-65535	0	-	✓	✓	✓	
15-24	AS1 Current Value	0-65535	0	-	✓	✓	✓	
15-25	AS2 Current Value	0-65535	0	-	✓	✓	✓	
15-26	AS3 Current Value	0-65535	0	-	✓	✓	✓	
15-27	AS4 Current Value	0-65535	0	-	✓	✓	✓	
15-28	MD1 Current Value	0-65535	0	-	✓	✓	✓	
15-29	MD2 Current Value	0-65535	0	-	✓	✓	✓	
15-30	MD3 Current Value	0-65535	0	-	✓	✓	✓	
15-31	MD4 Current Value	0-65535	0	-	✓	✓	✓	
15-32	TD Current Value	0-65535	0	-	✓	✓	✓	

Group 16 LCD Keypad Parameters								
Param. #	Parameters	Setting Range	Default	Unit	Control Mode			Notes
					V/F	SLV	PMSLV	
16-00	Main Screen Monitoring	5-39 when using LCD to operate, the monitored item displays in the first line. (default is frequency command)	16	-	✓	✓	✓	*1
16-01	Sub-Screen Monitoring 1	5-39 when using LCD to operate, the monitored item displays in the second line. (default is output frequency)	17	-	✓	✓	✓	*1

Group 16 LCD Keypad Parameters								
Param. #	Parameters	Setting Range	Default	Unit	Control Mode			Notes
					V/F	SLV	PMSLV	
16-02	Sub-Screen Monitoring 2	5–39 when using LCD to operate, the monitored item displays in the third line. (default is output current))	18	-	✓	✓	✓	*1
16-03	Display Unit	0–39999: Determine the display way and unit of frequency commands 0: Frequency display unit is 0.01Hz 1: Frequency display unit is 0.01% 2: Frequency display unit is rpm. 3–39: Reserved 40–9999: Users specify the format, Input 0XXXX represents display of XXXX at 100%. 10001–19999: Users specify the format Input 1XXXX represents display of XXX.X at 100%. 20001–29999: Users specify the format, Input 2XXXX represents display of XX.XX at 100%. 30001–39999: Users specify the format, Input 3XXXX represents display of X.XXX at 100%.	0	-	✓	✓	✓	
16-04	Engineering Unit	0: Without using engineering units 1: FPM 2: CFM 3: PSI 4: GPH 5: GPM 6: IN 7: FT 8: /s 9: /m 10: /h 11: °F 12: inW 13: HP 14: m/s 15: MPM 16: CMM 17: W 18: KW 19: m 20: °C 21: RPM 22: Bar 23: Pa 24: KPa	0	-	✓	✓	✓	
16-05	LCD Backlight	0–7	5	-	✓	✓	✓	

Group 16 LCD Keypad Parameters								
Param. #	Parameters	Setting Range	Default	Unit	Control Mode			Notes
					V/F	SLV	PMSLV	
16-07	Copy Function	0: Do not copy parameters 1: Read AC Drive parameters and store parameters settings in the operator. 2: Write the operator parameters to the AC Drive. 3: Compare operator parameters against AC Drive.	0	-	✓	✓	✓	
16-08	Parameter Read Allow	0: Do not allow to read AC Drive parameters or save them to the operator. 1: Allow to read AC Drive parameters and save to the operator.	0	-	✓	✓	✓	
16-09	Operator Removed	0: Continue operation when LCD operator is removed. 1: Display fault when LCD operator is removed	0	-	✓	✓	✓	

*1: Parameter can be changed while running.

Group 17 Automatic Tuning Parameters								
Param. #	Parameter Name	Setting Range	Default	Unit	Control Mode			Notes
					V/F	SLV	PMSLV	
17-00	Automatic Tuning Mode	0: Rotation Auto-tuning 1: Static Auto-tuning 2: Stator Resistance Measurement 3: Reserved 4: Loop Tuning 5: Rotation Auto-tuning Combination (item: 4+2+0) 6: Static Auto-tuning Combination (item: 4+2+1)	V/F: 2 SLV: 6	-	✓	✓	X	(note)
17-01	Motor Rated Output Power	0.00–600.00	Per Model	KW	✓	✓	X	*9, (note)
17-02	Motor Rated Current	0.1–1200.0	Per Model	A	✓	✓	X	*9, (note)
17-03	Motor Rated Voltage	240V: 50.0–240.0 480V: 100.0–480.0	Per Model	V	✓	✓	X	*9
17-04	Motor Rated Frequency	4.8–599.0	Per Model	Hz	✓	✓	X	*9
17-05	Motor Rated Speed	0–24000	Per Model	rpm	✓	✓	X	*9, (note)
17-06	Motor Poles	2–16(Even)	4	Pole	✓	✓	X	
17-08	Motor no-load Voltage	240V: 50–240 480V: 100–480	-	V	✓	✓	X	(note)
17-09	Motor Excitation Current	0.01–600.00	-	A	X	✓	X	(note)
17-10	Automatic Tuning Start	0: Disable 1: Enable	0	-	✓	✓	X	
17-11	Automatic Tuning Error History	0: No error 1: Motor data error 2: Stator resistance tuning error 3: Leakage induction tuning error 4: Rotor resistance tuning error 5: Mutual induction tuning error 6: DT Error 7: Encoder error 8: Motor's acceleration error 9: Warning	0	-	✓	✓	X	

Group 17 Automatic Tuning Parameters								
Param. #	Parameter Name	Setting Range	Default	Unit	Control Mode			Notes
					V/F	SLV	PMSLV	
17-12	Motor Leakage Inductance Proportion	0.1–15.0	Per Model	%	X	✓	X	*9
17-13	Motor Slip Frequency	0.10–20.00	Per Model	Hz	X	✓	X	*9
17-14	Rotation Auto-tuning	0: V/f Rotation Auto-tuning 1: Vector Rotation Auto-tuning	0	-	✓	✓	X	

17-00: Automatic Tuning Mode by default is 6 (Static Auto-tuning Combination). When auto-tuning with a no-load motor, it is recommended to select 17-00=5 (Rotation Auto-tuning Combination). Caution! Motor will turn during Rotation Auto-Tuning

17-01, 17-02, 17-05: The default value of this parameter will be changed according to the AC Drive capacity
It is recommended that HD/ ND mode (00-27) be selected first before motor performs auto-tuning.

17-08 and 17-09: Do not adjust, contact factory before making any changes to these parameters.

***9:** Parameter default setting is dependent on drive size/model.

Group 18 Slip Compensation Parameters								
Param. #	Parameters	Setting Range	Default	Unit	Control mode			Notes
					V/F	SLV	PMSLV	
18-00	Slip Compensation Gain at Low Speed.	0.00–2.50	VF:0.00	-	✓	✓	X	*1, (note)
			SLV:*					
18-01	Slip Compensation Gain at High Speed.	-1.00–1.00	0	-	✓	✓	X	*1
18-02	Slip Compensation Limit	0–250	200	%	✓	X	X	
18-03	Slip Compensation Filter Time	0.0–10.0	1	Sec	✓	X	X	
18-04	Regenerative Slip Compensation Selection	0: Disable	0	-	✓	X	X	
		1: Enable						
18-05	FOC Delay Time	1–1000	100	ms	X	✓	X	
18-06	FOC Gain	0.00–2.00	0.1	-	X	✓	X	

18-00: Default depends on value of parameter 13-00. Refer to section 4.2.2 Parameter Details for additional information

***1:** Parameter can be changed while running

Group 20 Speed Control Parameters								
Param. #	Parameters	Setting Range	Default	Unit	Control Mode			Notes
					V/F	SLV	PMSLV	
20-00	ASR Gain 1	0.00–250.00	SLV: 6 PMSLV: 3	-	X	✓	✓	*1
20-01	ASR Integral Time 1	0.001–10.000	SLV: 0.5 PMSLV: 0.08	Sec	X	✓	✓	*1
20-02	ASR Gain 2	0.00–250.00	SLV: 6 PMSLV: 3	-	X	✓	✓	*1
20-03	ASR Integral Time 2	0.001–10.000	SLV: 0.5 PMSLV: 0.6	Sec	X	✓	✓	*1
20-04	ASR Integral Time Limit	0–300	200	%	X	✓	✓	
20-07	P/PI Acceleration and Deceleration	0: PI speed control will be enabled only in constant speed. For speed acceleration and deceleration, only use P control. 1: Speed control is enabled in either acceleration or deceleration.	0	-	X	✓	X	

Group 20 Speed Control Parameters								
Param. #	Parameters	Setting Range	Default	Unit	Control Mode			Notes
					V/F	SLV	PMSLV	
20-08	ASR Delay Time	0.000–0.500	0.004	Sec	X	✓	✓	
20-09	Speed Observer Proportional (P) Gain1	0.00–2.55	0.61	-	X	✓	X	*1
20-10	Speed Observer Integral(I) Time 1	0.01–10.00	0.05	Sec	X	✓	X	*1
20-11	Speed Observer Proportional (P) Gain2	0.00–2.55	0.61	-	X	✓	X	*1
20-12	Speed Observer Integral(I) Time 2	0.01–10.00	0.06	Sec	X	✓	X	*1
20-13	Speed Feedback 1 Low-pass Filter Time Constant	1–1000	4	ms	X	✓	X	
20-14	Speed Feedback 2 Low-pass Filter Time Constant	1–1000	30	ms	X	✓	X	
20-15	ASR Gain Change Frequency 1	10.0–599.0	4	Hz	X	✓	✓	
20-16	ASR Gain Change Frequency 2	0.0–599.0	8	Hz	X	✓	✓	
20-17	Torque Compensation Gain at Low Speed	0.00–2.50	1	-	X	✓	X	*1
20-18	Torque Compensation Gain at High Speed	-10–10	0	%	X	✓	X	*1
20-33	Detection Level at Constant Speed	0.1–5.0	1	-	X	✓	✓	*1
20-34	Derating Compensation Gain	0–25600	0	-	X	✓	X	*1
20-35	Derating Compensation Time	0–30000	100	ms	X	✓	X	*1

*1: Parameter can be changed while running

Group 21 Torque And Position Control Parameters								
Param. #	Parameters	Setting Range	Default	Unit	Control mode			Notes
					V/F	SLV	PMSLV	
21-05	Positive Torque Limit	0–300	150	%	X	✓	✓	
21-06	Negative Torque Limit	0–300	150	%	X	✓	✓	
21-07	FWD Regen Torque Limit	0–300	150	%	X	✓	✓	
21-08	REV Regen Torque Limit	0–300	150	%	X	✓	✓	

Group 22 PM Motor Parameters								
Param. #	Parameters	Setting Range	Default	Unit	Control Mode			Notes
					V/F	SLV	PMSLV	
22-00	PM Motor Rated Power	0.00–600.00	Per Model	kW	X	X	✓	*9, (note)
22-02	PM Motor Rated Current	25%–200% AC Drive rated current	Per Model	A	X	X	✓	*9, (note)
22-03	PM Motor's Pole Number	2–96	Per Model	poles	X	X	✓	*9, (note)
22-04	PM Motor's Rotation Speed	6–65535	Per Model	rpm	X	X	✓	*9, (note)
22-05	PM Motor's Maximum Rotation Speed	6–65535	Per Model	rpm	X	X	✓	*9, (note)
22-06	PM Motor Rated Freq.	4.8–599.0	Per Model	Hz	X	X	✓	*9, (note)
22-10	PM SLV Start Current	20% – 120% Motor Rated Current	50	%	X	X	✓	
22-11	I/F Mode Start Frequency Switching Point	1.0 – 20.0	10	%	X	X	✓	
22-14	PM Motor Armature Resistance	0.001 – 30.000	1	Ω	X	X	✓	
22-15	PM Motor D-axis Inductance	0.01 –300.00	10	mH	X	X	✓	
22-16	PM Motor Q-axis Inductance	0.01 – 300.00	10	mH	X	X	✓	
22-18	Flux-Weakening Limit	0–100	0	%	X	X	✓	
22-21	PM Motor Tuning	0: PM Motor Tuning is not Active. 1: Parameter Auto-tune 1	0	-	X	X	✓	
22-22	PM Motor Tuning Fault	0: No Faults 5: Loop Adjustment Timed Out 7: Other Motor Tuning Errors 9: Current Abnormal during Loop Adj.	0	-	X	X	✓	*4
22-23	PMSLV acceleration time	0.1–10.0	1	Sec	X	X	✓	
22-25	Initial Rotor Position Detection	0: Disable 1: Detected Using Input Pulse Signal	1	-	X	X	✓	

22-00 to 22-06: Value will depend on motor data

*4: Read-only Parameter

*9: Parameter default setting is dependent on drive size/model.

4.2.1: Parameter default values and ranges depending on AC Drive model

Model	Frame	Maximum Output Frequency (Hz) in SLV Mode when 11-01 ≤ 8KHz	Maximum Output Frequency (Hz) in SLV Mode when 11-01 > 8KHz	Factory setting of 11-01 in HD mode	The maximum value of 11-01 in HD mode (SLV control mode)	The maximum value of 11-01 in HD mode (Other control modes)
20P5	1	150	150	5	16	16
2001				5	16	16
2002	2	150	150	5	16	16
2003				5	16	16
2005				5	16	16
27P5	3	150	150	5	16	16
2010				5	16	16
2015	4	110	110	5	16	16
2020				5	16	16
2025	5	100	80	5	8	12
2030	6	100	80	5	8	12
2040				5	8	12
4001	1	150	150	5	16	16
4002				5	16	16
4003	2	150	150	5	16	16
4005				5	16	16
47P5	3	150	150	5	16	16
4010				5	16	16
4015				5	16	16
4020	4	110	110	5	16	16
4025		100	100	5	16	16
4030	5	100	80	5	8	16
4040	6	100	80	5	8	12
4050				5	8	12
4060				5	8	10
4075				5	8	10

Model	Default value of 21-05-21-08 (Torque limit)	Default value of 20-08 (ASR delay time)	Default value of 00-14-00-17 00-21-00-24	Heat Sink Temperature Displayed, Parameter 12-41	SLV default value (18-00) (Low speed slip compensation)
20P5	200%	0.001	10	YES	1
2001					
2002	200%	0.001	10	YES	1
2003					
2005					
27P5	200%	0.001	10	YES	1
2010					
2015	200%	0.002	15	YES	1
2020					
2025	160%	0.002	20	YES	0.7
2030	160%	0.004	20	YES	0.7
2040					
4001	200%	0.001	10	YES	1
4002					
4003	200%	0.001	10	YES	1
4005					
47P5	200%	0.001	10	YES	1
4010					
4015					
4020	200%	0.002	15	YES	1
4025					
4030	160%	0.002	20	YES	0.7
4040	160%	0.004	20	YES	0.7
4050					
4060					
4075					

4.3 Parameter Details

00 Basic Parameters

00-00	Control Mode Selection	Default: 0
Range	【0】 : V/F 【2】 : SLV 【5】 : PMSLV	

The AC Drive offers the following control modes:

00-00=0: V/F Mode without encoder

For the quickest out-of-box setup or when controlling multiple motors from on AC drive, use V/F mode. V/F mode is ideal for loads where precise speed regulation is not needed (regulation is approximately 2-3% of set speed). V/F mode will work for 95% of motor loads and requires only motor full load amps (FLA) be set in order to protect the motor. Auto-tuning is not required. For more V/F mode settings, see parameter Group 1.

If desired, select a V/F curve (01-00) based on your motor and application.

Perform a stationary auto-tune (17-00=1), if the motor cable is longer than 50m (165ft); see parameter 17-00 for details.

00-00=2: Sensorless Vector Control without encoder

SLV mode can provide greater regulation of motor speed but requires tuning of the drive to individual motor. SLV mode cannot run multiple motors from one AC drive. SLV mode is ideal where precise speed control is needed or when 100% of motor torque is required at a low operating speed. For SLV auto-tuning, see parameter Group 17.

00-00=5: PM Sensorless Vector Control without encoder

PMSLV mode is identical to SLV mode but using a permanent magnet motor. For PMSLV auto-tuning, see parameter Group 22.

Note: Parameter 00-00 is not changed during initialization.

00-01	Motor's Rotation Direction	Default: 0
Range	【0】 : Forward 【1】 : Reverse	

Use the FWD/REV key to change motor direction when Run Command (00-02 = 0) is set to keypad control.

00-02	Main Run Command Source	Default: 0
Range	【0】 : Keypad 【1】 : External Terminal (Control Circuit) 【2】 : Communication Control (RS-485) 【3】 : PLC	

Note: To switch the command source between the setting of main (00-02) and alternative (00-03) assign one of the DI (S1 to S6) to be the "Run Command Switch Over" (03-00–03-05=12).

00-02/00-03=0: Keypad Control

Use the keypad to start and stop the AC Drive and set direction with the forward / reverse key. Refer to section 4-1 for details on the keypad.

00-02/00-03=1: External Terminal Control

External terminals are used to start and stop the AC Drive and select motor direction. There are three different types: 2-wire operation, 3-wire operation, and 2-wire self-holding (latching) mode. See instruction details for parameter 00-04 for more information.

00-02/00-03=2: Communication control

The AC Drive is controlled by the RS-485 port. Refer to parameter Group 9 for communication setup.

Example:

Command String in hexadecimal: 01 06 25 01 00 01 12 C6

00-02/00-03=3: PLC control

The AC Drive is controlled by the AC Drive built-in PLC logic. Refer to chapter 5.

00-03	Alternative Run Command Source	Default: 2
Range	【0】 : Keypad 【1】 : External Terminal (Control Circuit) 【2】 : Communication Control (RS-485) 【3】 : PLC	

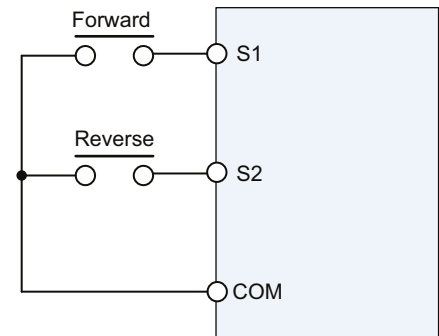
00-04	Operation Modes for External Terminals	Default: 0
Range	【0】 : Forward/Stop-Reverse/Stop 【1】 : Run/Stop- Reverse/ Forward 【2】 : 3 Wire Control Mode - Run/Stop	

Note: 00-04 is valid when run command is set to external mode by 00-02/00-03 =1.

2 Wire Operation Mode,

Set 00-04 to **【0】** or **【1】** first, before setting 03-00 (S1 terminal selection) to 0 and 03-01 (S2 terminal selection) to 1

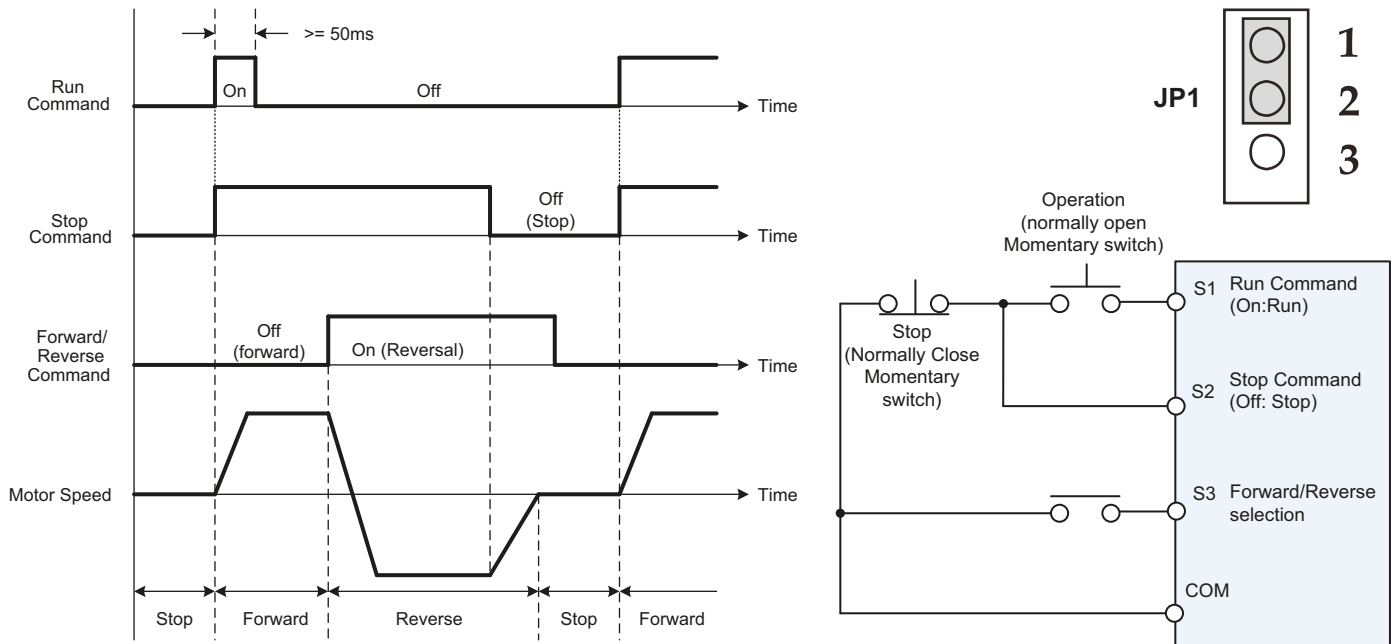
Terminal S1	Terminal S2	Operation
Open	Open	Stop AC Drive
Closed	Open	Run Forward
Open	Closed	Run Reverse
Closed	Closed	Stop AC Drive, Display EF9 Alarm after 500ms



3-wire operation

Set parameter 00-04 to 2 for 3-wire program initialization, multi-function input terminal S1 is set to run operation, S2 for stop operation and S3 for forward/reverse command. Ensure JP1 is set to position 1 and 2.

Note: Terminal S1 must be closed for a minimum of 50ms to activate operation.



Param. #	Parameter Name	Default	Range
00-05	Main Frequency Command Source Selection	1	【0】 : Up/Down on Keypad 【1】 : Potentiometer on Keypad 【2】 : External AI1 Analog Signal Input 【3】 : External AI2 Analog Signal Input 【4】 : External Up/Down Frequency Control
00-06	Alternative Frequency Source Selection	0	【5】 : Communication Setting Frequency 【6】 : Reserved 【7】 : Pulse Input

00-05/00-06= 0: Keypad

Enter the frequency reference by using the keypad or by setting parameter 05-01 (frequency reference 1). Note that once the frequency command is switched to alternative frequency reference and 00-06 is set to 0, the frequency can be adjusted using parameter 05-01.

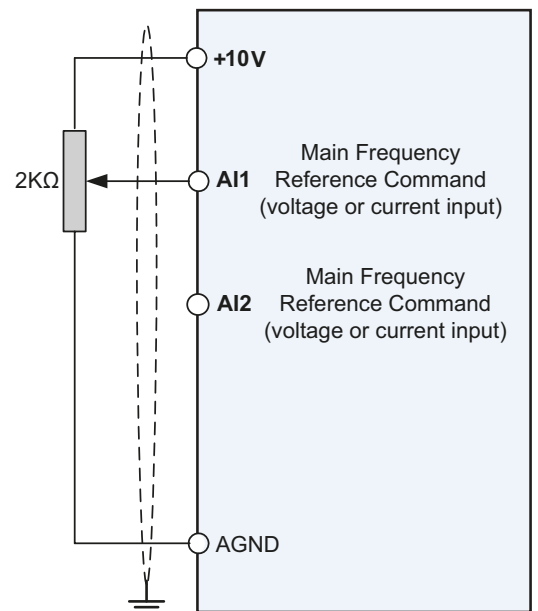
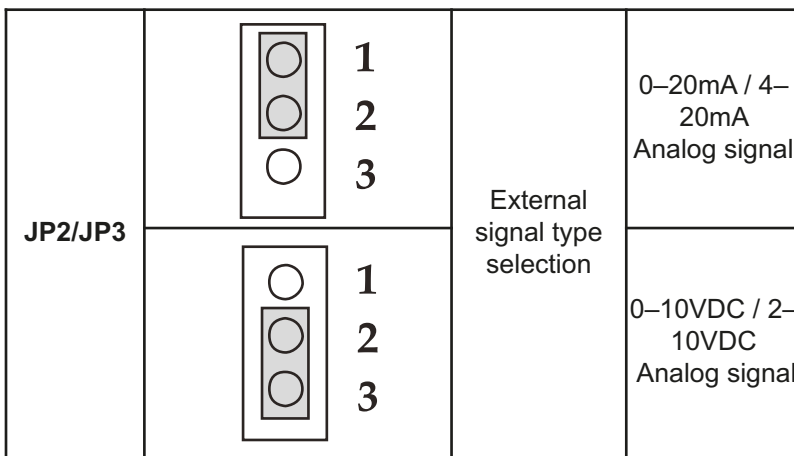
00-05/00-06= 1: Potentiometer on Keypad

Use the keypad potentiometer to set frequency reference

00-05/00-06= 2, 3: External Analog Input AI1 / External Analog Input AI2

Set any of the multi-function terminals (03-00–03-05) to 13 to switch between main and alternate frequency.

Use analog reference from analog input AI1 or AI2 to set the frequency reference (as shown below). Refer to parameter 04-00 to select the signal type.



00-05/00-06= 4: Terminal UP / DOWN

The AC Drive accelerates with the UP command active and decelerates with the DOWN command active. Please refer to parameter 03-00 – 03-05 for additional information.

Note: To use this function both the UP and DOWN command have to be set to any of the input terminals.

00-05/00-06= 5: Communication Control

The frequency reference command is set via the RS-485 communication port.

Example:

Frequency Reference Command: 10.00Hz (AC Drive Node Address: 01)

Command String in Hexadecimal: 01 06 25 02 03 E8 23 B8

To set the frequency reference to 10.00, a value of “1000” (03E8h) has to be sent to the AC Drive.

Refer to parameter group 9 for additional information.

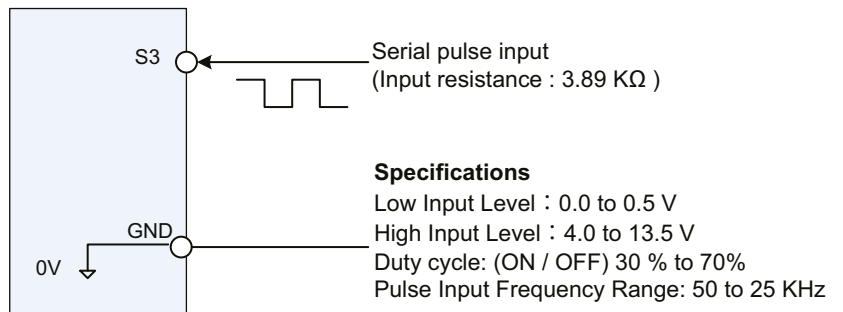
00-05/00-06= 6: Reserved

00-05/00-06= 7: Pulse Input

Frequency reference from an external pulse input. Can be used only with multi-function input terminal S3 (**03-02 = 25 or 26**). See parameter group 3 multi-function input selections 25 and 26.

Example:

Pulse input frequency is 20Hz, frequency upper limit is 50Hz (**00-12=50.00**), and **03-30=1**. AC Drive frequency is 20.00Hz.



00-07	Main and Alternative Frequency Command Modes	Default: 0
Range	【0】 : Main reference frequency 【1】 : Main frequency + alternative frequency	

When set to 0, the reference frequency is set by the main reference frequency of parameter 00-05. When set to 1 the reference frequency is sum of the main reference frequency (00-05) and alternative frequency (00-06).

Note: The AC Drive will display the SE1 error when 00-07 = 1 and parameter 00-05 and 00-06 are set to the same selection.

When parameter 00-06 is set to 0 (Keypad) the alternative frequency reference is set by parameter 05-01 (Frequency setting of speed-stage 0).

00-08	Communication Frequency Command – READ ONLY	Default: –
Range	【0.00–599.00】 : Hz	

Display the frequency reference when 00-05 or 00-06 is set to communication control (3).

00-09	Communication Frequency Command Memory	Default: 0
Range	【0】 : Do not store the communication frequency at power down 【1】 : Store communication frequency at power down	

Note: This parameter is only active when frequency reference is set via communication (00-05 / 00-06)

00-10	Initial Frequency Selection	Default: 0
Range	【0】 : By Current Freq Command 【1】 : By Zero Freq Command 【2】 : By 00-11	

Notes:

- This parameter is only active in keypad mode
- When 00-10= **【0】** , the initial frequency will be current frequency.
- When 00-10= **【1】** , the initial frequency will be 0.
- When 00-10= **【2】** , the initial frequency is set by parameter 00-11.

00-11	Initial Frequency Setpoint	Default: Per Model
Range	【0.00–599.00】 Hz	

Initial Frequency Setpoint range depends on the setting of 01-02 and 01-08 or 01-16 and 01-22 for V/F and SLV modes. PMSLV mode depends on parameter 22-06.

00-12	Upper Limit Frequency	Default: Per Model
Range	【0.01–599.00】 Hz	

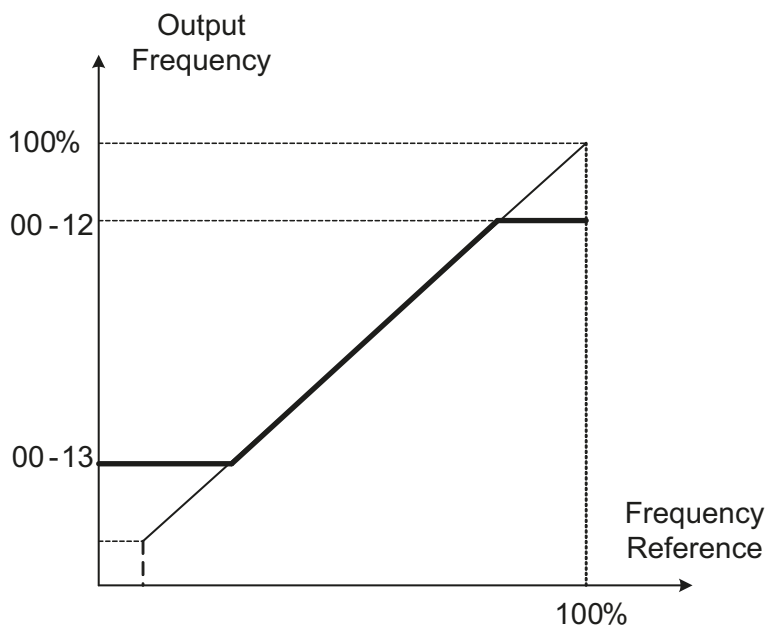
Upper Limit Frequency range depends on the setting of 01-02 or 01-16 for V/F and SLV modes. PMSLV mode depends on setting of 22-06.

00-13	Lower Limit Frequency	Default: 0
Range	【0.01–598.99】 Hz	

Lower Limit Frequency range depends on the setting of 01-08 or 01-22 for V/F and SLV modes. PMSLV mode depends on setting of 22-06.

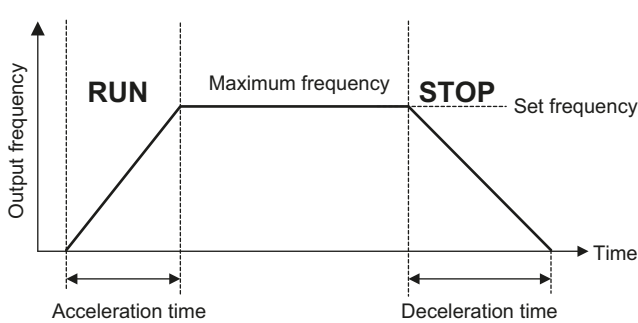
The AC Drive will display the SE01 error when 00-12 value is set lower than value in parameter 00-13.

Frequency upper and lower limits are active for all frequency reference modes.

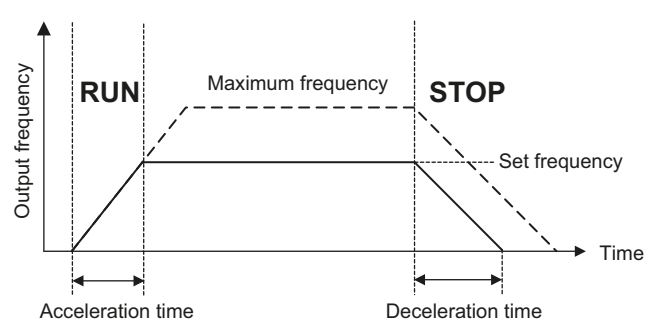


00-14	Acceleration Time 1	Default: Per Model
Range	【0.1–6000.0】 Sec	
00-15	Deceleration Time 1	Default: Per Model
Range	【0.1–6000.0】 Sec	
00-16	Acceleration Time 2	Default: Per Model
Range	【0.1–6000.0】 Sec	
00-17	Deceleration Time 2	Default: Per Model
Range	【0.1–6000.0】 Sec	

Acceleration and deceleration times are represented by the three most significant (high order) digits. Set acceleration and deceleration times with respect to maximum frequency.



Set Frequency = Maximum Frequency



Set Frequency < Maximum Frequency

Notes:

- Acceleration time is the time required to accelerate from 0 to 100% of maximum output frequency.
- Deceleration time is the time required to decelerate from 100 to 0% of maximum output frequency.
- Maximum frequency is set by parameter 01-02 or 01-16.
- If parameter 01-00=18, Maximum output frequency is set by parameter 01-02 or 01-16.
- If parameter 01-00≠18, Maximum output frequency = 50.00 or 60.00 depending on initialization mode.
- The default values for the acceleration / deceleration times are dependent on the AC Drive size.
- If the set acceleration and deceleration times are set too low, the torque limiting function or stall prevention function can become activated if the load torque and/or inertia are relatively high. This will prolong the acceleration and or deceleration times and not allow the set times to be followed.

AC Drive Size		Acceleration / Deceleration Default Value
240V Series	480V Series	
1–10HP	1–15HP	10s
15–20HP	20–30HP	15s
30–40HP	40–75HP	20s

$$\text{Actual acceleration time} = \frac{(00-14) \times (\text{set frequency} - \text{Min. Starting Freq. "00-11"})}{\text{Max. Output Freq. "00-12"}}$$

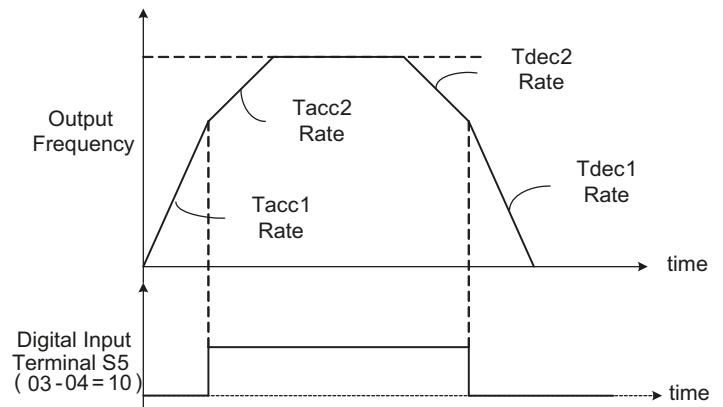
$$\text{Actual deceleration time} = \frac{(00-15) \times (\text{set frequency} - \text{Min. Starting Freq. "00-11"})}{\text{Max. Output Freq. "00-12"}}$$

Note: For additional acceleration/deceleration times, see parameters 00-21 through 00-24.

A: Select acceleration and deceleration time via the digital input terminals

The following table shows the acceleration / deceleration selected when the digital input function Accel / Decel time 1 is used.

Accel/Decel time 1 (Set 03-00 to 03-05 = 10)	Acceleration Time	Deceleration Time
0	Tacc1 (00-14)	Tdec1 (00-15)
1	Tacc2 (00-16)	Tdec2 (00-17)
0 : OFF (open) 1 : ON (closed)		



B: Switch of Acceleration / Deceleration time based on motor selection

When 03-00–03-05 is set to 40 (motor 1/motor 2 selection), motor 1 or motor 2 can be selected via the digital input. This function is only available in V/F control mode.

00-18	Jog Frequency	Default: 2
Range	【1.00–25.00】 Hz	
00-19	Jog Acceleration Time	Default: Per Model
Range	【0.1–25.5】 Sec	
00-20	Jog Deceleration Time	Default: Per Model
Range	【0.1–25.5】 Sec	

The JOG function is operational by using the multi-function input terminals S1 to S6 and setting the relevant parameters 03-00–03-05 to **【6】** JOG FWD or **【7】** JOG REV. Refer to parameter group 3.

Notes:

- To activate the JOG FWD function set any of the multi-function input terminals S1 to S6 to 6.
- To activate the JOG REV function set any of the multi-function input terminals S1 to S6 to 7.
- Jog acceleration time (00-19) is the time required to accelerate from 0 to 100% of maximum output frequency.
- Jog deceleration time (00-20) is the time required to decelerate from 100 to 0% of maximum output frequency.
- Maximum frequency is set by parameter 01-02 or 01-16.
- The AC Drive uses the Jog frequency (00-18, default 2.0 Hz) as its frequency reference when jog is active.

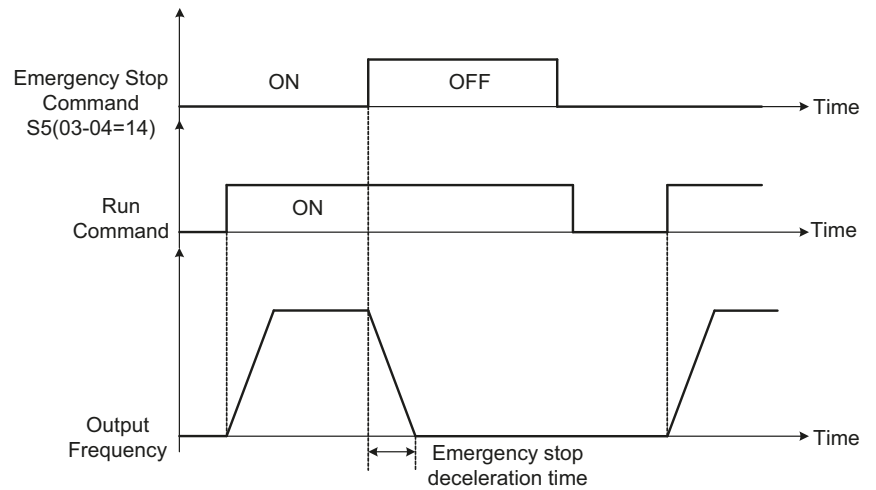
00-21	Acceleration Time 3	Default: Per Model
Range	【0.1–6000.0】 Sec	
00-22	Deceleration Time 3	Default: Per Model
Range	【0.1–6000.0】 Sec	
00-23	Acceleration Time 4	Default: Per Model
Range	【0.1–6000.0】 Sec	
00-24	Deceleration Time 4	Default: Per Model
Range	【0.1–6000.0】 Sec	

00-26	Emergency Stop Time	Default: 5
Range	【0.1–3600.0】 Sec	

The emergency stop time is used in combination with multi-function digital input function #14 (Emergency stop) or #15 (Base block). When emergency stop input is activated the AC Drive will decelerate to a stop using the Emergency stop time (00-26).

Note:

To cancel the emergency stop condition the run command has to be removed and emergency stop input deactivated.



Multi-function digital input terminals (03-00 – 03-05) set to 14: When the emergency stop input is activated the AC Drive will decelerate to a stop using the time set in parameter 00-26.

Note:

After an emergency stop command the run command and emergency stop command have to be removed before the AC Drive can be restarted. The emergency stop function can be used to stop AC Drive in case of an external event.

00-27	HD/ND Mode	Default: 0
Range	【0】 : HD (Heavy Duty / Constant Torque) 【1】 : ND (Normal Duty / Variable Torque)	

The AC Drive overload curve, carrier frequency, stall prevention level, rated input/output current and maximum frequency are automatically set based on the AC Drive duty (HD/ND) selection.

Please refer below for detailed information

00-27	Overload capacity	Carrier frequency	Maximum output frequency	Stall prevention level	Rated input / output current
0 (Heavy Duty)	150%, 1min	2-16KHz (Model dependent)	599.00Hz	150% (08-00, 08-01)	Refer to section 2.3
1 (Normal Duty)	120%, 1min	2-16KHz (Model dependent)	120.00Hz	120% (08-00, 08-01)	

Note:

Dual rating can only be used for 240V Class 25HP and above and 480V class 30HP and above (Frames 5 and 6). Select V/F curve (Group 1) and enter motor data (Group 2) to match your application. In Heavy Duty mode the maximum output frequency is 599Hz for all control modes, except for SLV mode (Sensorless Vector / Open Loop Vector Mode) where the maximum output frequency is limited based on the AC Drive rating. See table below.

Horsepower	Carrier Frequency Limit	Maximum output frequency
220V 1–10HP, 440V 1–15HP	-	150Hz
220V 15–25HP, 440V 20HP	-	110Hz
440V 25–30HP	-	100Hz
220V 30–40HP, 440V 40–75HP,	11-01 set 8KHz or below	100Hz
220V 30–40HP, 440V 40–75HP,	11-01 set 8KHz or higher	80Hz

Note:

Normal duty mode only available in V/F mode. All other modes must use the Heavy Duty setting.

00-34	Language	Default: 0
Range	【0】 English 【1】 Simplified Chinese 【2】 Traditional Chinese 【3】 Turkish	

LCD keypad is required to display languages.

Selection of parameter 00-34

00-34=0: LCD keypad displays in English.

00-34=1: LCD keypad displays in Simplified Chinese.

00-34=2: LCD keypad displays in Traditional Chinese.

00-04=3: LCD keypad displays in Turkish.

Note:

Parameter 00-34 Language setting is not affected by drive initializing (see parameter 13-08).

00-35	Minimum Frequency Detection	Default: 0
Range	【0】 Alarm 【1】 Keep Running at Lower Frequency	

00-35=0: Alarm

When output frequency falls below the minimum frequency (01-08), display shows STP0 alarm.

00-35=1: Keep Running at Lower Frequency

When the output frequency falls below the minimum frequency, the AC Drive will keep running at minimum frequency.

00-36	PID Lower Frequency Selection	Default: 0
Range	【0】 Lower Frequency of PID Sleep Mode 【1】 0Hz of PID Sleep Mode	

00-36=0: Lower Frequency of PID Sleep Mode

PID sleep frequency is used (parameter 10-17).

00-36=1: 0Hz of PID Sleep Mode

PID sleep frequency is 0Hz.

01 V/F Control Parameters

01-00	Volts/Hz Patterns	Default: 1
Range	【0-FF】	

The V/F curve selection is enabled for V/F mode. Make sure to set the AC Drive input voltage parameter 01-14.

There are three ways to set V/F curve:

- (1) 01-00 = 0 to 0E: choose any of the 15 predefined curves.
- (2) 01-00 = 0F, use 01-02 to 01-09 and 01-12 to 01-13, with voltage limit
- (2) 01-00 = FF, use 01-02 to 01-09 and 01-12 to 01-13, without voltage limit

Custom curves F and FF use identical curves to 0 (for 50Hz) or 1 (for 60Hz) as a baseline.

Parameters 01-02 to 01-13 are automatically set when any of the predefined V/F curves are selected.

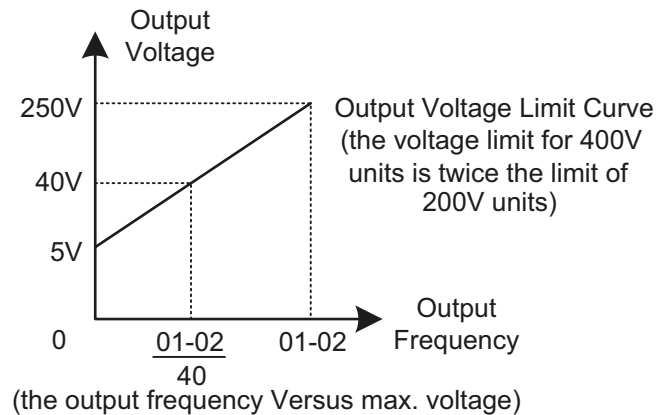
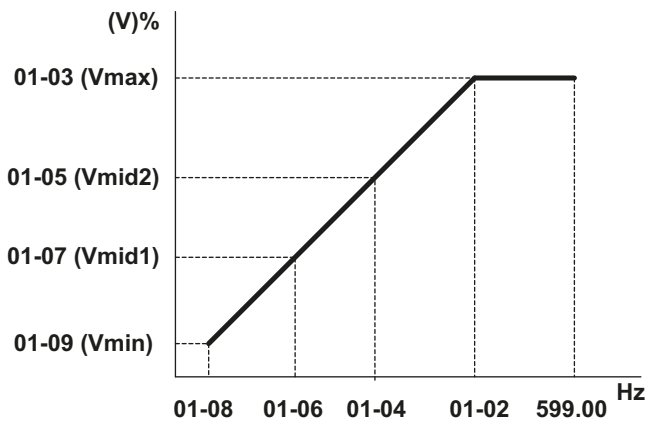
Note:

Parameters 01-02 to 01-09 and 01-12 to 01-13 are only editable when 01-00=FF. (01-16 to 01-25 for motor 2)

V/F curve selection

Consider the following items as the conditions for selecting a V/F pattern.

- (1) The voltage and frequency characteristic of motor.
- (2) The maximum speed of motor.



Notes:

Parameter 01-00 V/f Pattern setting is not affected by drive initializing (see parameter 13-08)

When using the LED keypad, display will show H00XX indicating the value is to be input as a hexadecimal.

2P5 – 2HP V/F curve selection

Type	01-00	Specification	V/F curve	01-00	Specification	V/F curve
General purpose	0	50Hz		8	Low Starting Torque	
	F (50Hz Default)			9	High Starting Torque	
	1 (60Hz Default)	60Hz	60Hz Saturation	A	Low Starting Torque	
	F			B	High Starting Torque	
	2		50Hz Saturation			
	Variable Torque Characteristic	3	72Hz		C	90Hz
4		50Hz	Variable Torque 1	D	120Hz	
5			Variable Torque 2			
6		60Hz	Variable Torque 3	E	180Hz	
7			Variable Torque 4			

3 – 30HP V/F curve selection

Type	01-00	Specification	V/F curve	01-00	Specification	V/F curve		
General purpose	0	50Hz		8	50Hz			
	F (50Hz Default)			9			High Starting Torque	
	1	60Hz	60Hz Saturation		A	60Hz		
	F (60Hz Default)				B			High Starting Torque
	2				50Hz Saturation			
	Variable Torque Characteristic	3	72Hz		C	90Hz		
4		50Hz	Variable Torque 1		D	120Hz		
5			Variable Torque 2		E	180Hz		
6		60Hz	Variable Torque 3					
7			Variable Torque 4					

40HP and above V/F curve selection

Type	01-00	Specification	V/F curve	01-00	Specification	V/F curve
General purpose	0	50Hz		8	50Hz	
	F (50Hz Default)			9		High Starting Torque
	1	60Hz		A	60Hz	
	F (60Hz Default)		60Hz Saturation			B
Variable Torque Characteristic	3	72Hz		C	90Hz	
	4	50Hz		D	120Hz	
	5		Variable Torque 1		E	180Hz
	6	60Hz				
	7		Variable Torque 2			
			Variable Torque 3			
		Variable Torque 4				

V/F curve setting

Select any of the predefined V/F curves setting '0' to 'E' that best matches your application and the load characteristic of your motor. Choose a custom curve setting 'F' or 'FF' to set a custom curve.

01-02	Maximum frequency output motor 1	Default: 50.0/60.0
Range	【4.8–599.0】 Hz	
01-03	Maximum output voltage motor 1	Default: 230 or 400
Range	240V: 【0.1–255.0】 V	
	480V: 【0.2–510.0】 V	
01-04	Middle output frequency 2 motor 1	Default: 0
Range	【0.1–599.0】 Hz	
01-05	Middle output voltage 2 motor 1	Default: 0
Range	240V: 【0.0–255.0】 V	
	480V: 【0.0–510.0】 V	
01-06	Middle output frequency 1 motor 1	Default: 3
Range	【0.1–599.0】 Hz	
01-07	Middle output voltage 1 motor 1	Default: Per Model
Range	240V: 【0.0–255.0】 V	
	480V: 【0.0–510.0】 V	
01-08	Minimum output frequency motor 1	Default: V/F: 1.5, SLV: 0.6, PMSLV: 10
Range	【0.1–599.0】 Hz	
01-09	Minimum output voltage motor 1	Default: Per Model
Range	240V: 【0.0–255.0】 V	
	480V: 【0.0–510.0】 V	

Custom V/F curve setting

Custom curve “F” places a limitation on maximum voltage.

Custom curve “FF” does not have a limitation on the maximum voltage. This setting recommended for advanced users only, adjust with care.

When setting the frequency related parameters for custom V/F curve values make sure that:

$$\begin{matrix} \mathbf{F_{max}} > \mathbf{F_{base}} > \mathbf{F_{mid2}} > \mathbf{F_{mid1}} > \mathbf{F_{min}} \\ \mathbf{(01-02)} & \mathbf{(01-12)} & \mathbf{(01-04)} & \mathbf{(01-06)} & \mathbf{(01-08)} \end{matrix}$$

The 'SE03' V/F curve tuning error is displayed when the frequency values are set incorrectly.

Note:

Custom curves F and FF use the values from curve 0 (for 50Hz) or 1 (for 60Hz) as a baseline. If any changes are made to the custom curve from this baseline, all curve parameters must be updated with appropriate data (01-02 to 01-13 for motor 1 and 01-16 to 01-25 for motor 2)

Important:

Improper V/F curve selection can result in low motor torque or increased current due to excitation.

For low torque or high speed applications, the motor may overheat. Make sure to provide adequate cooling when operating the motor under these conditions for a longer period of time.

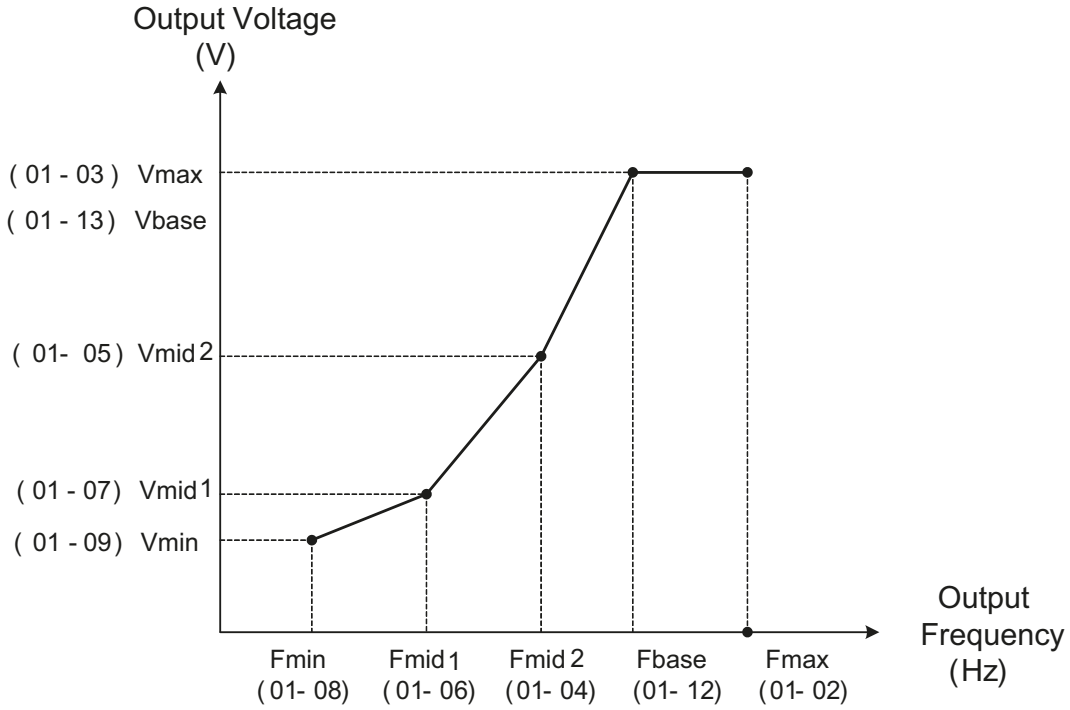
If the automatic torque boost function is enabled (parameter 01-10), the applied motor voltage will automatically change to provide adequate motor torque during start or operating at low frequency.

Do not adjust 01-02 or 01-12 to values other than motor nameplate specifications. Use parameters 00-12 and 00-13 to limit user accessible frequency range if desired.

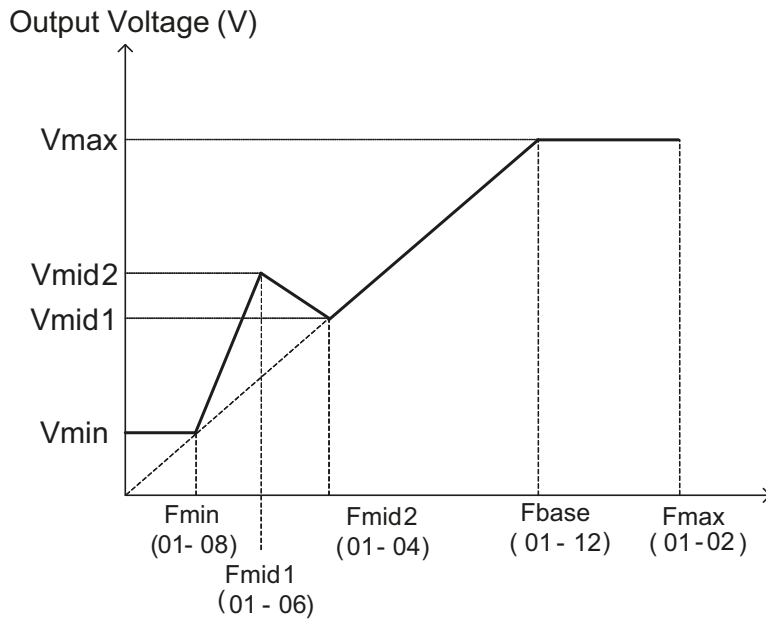
The value for maximum output voltage of the motor 1 (01-03) and the value for base output voltage of the motor (01-13) will depend on the setting of 13-08 which sets the value of voltage upon initialization.

When the control mode is changed in parameter 00-00, 01-08 (Fmin) and 01-09 (Vmin) will be automatically changed to the default setting of the selected control mode.

Custom V/F Curve



Torque Boosting



SLV Mode (Sensorless Vector Control)

Enter the motor data in parameter group 17 for SLV control mode (00-00) and perform auto-tuning.

In SLV mode, the V/F curve normally does not have to be re-adjusted after a successful auto-tune.

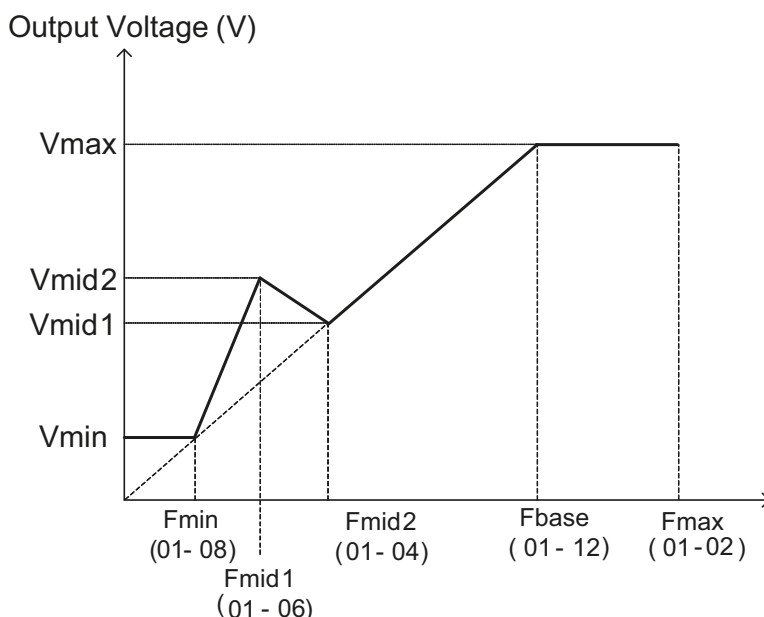
The maximum output frequency setting 01-02 (Fmax), base frequency 01-12 (Fbase), minimum output frequency 01-08 (Fmin), maximum output voltage 01-03 (Vmax) or base output voltage 01-13 (Vbase) can be manually adjusted but the voltage is automatically adjusted by the internal current controller.

Set the base frequency (01-12, Fbase) to the motor rated frequency on the motor nameplate.

Perform the auto-tuning procedure after adjusting parameters 02-19 or 17-04 to reduce the voltage at no-load operation.

Motor jitter can be reduced by lowering the no-load voltage which will increase the current.

Torque Boost / Compensation



01-10	Torque Boost	Default: 0.5
Range	【0.0–2.0】	
01-11	Torque Boost Mode	Default: 0
Range	【0】 Mode 0 (Normal) 【1】 Mode 1 (High Speed)	

Torque Boost (01-10)

In V/F mode, the AC Drive automatically adjusts the output voltage to increase output torque during start or load changes based on the calculated motor voltage loss.

Initial Setup

For Variable Torque / Normal Duty applications, set parameter 01-10 to an initial value of 0.5.

For Constant Torque / Heavy Duty applications, set parameter 01-10 to an initial value of 1.0.

01-10 Torque compensation gain

This parameter sets the torque boost for motor 1.

Torque compensation gain (01-10) can be adjusted at run time. Gradually change torque boost value to ensure output current does not exceed AC Drive rated current.

Increase Value When:

- Wire length between AC Drive and motor is too long
- Motor rating is smaller than AC Drive rating

Reduce Value When:

- Experiencing motor vibration
- Over current fault
- Overload fault

Torque Boost Mode (01-11)

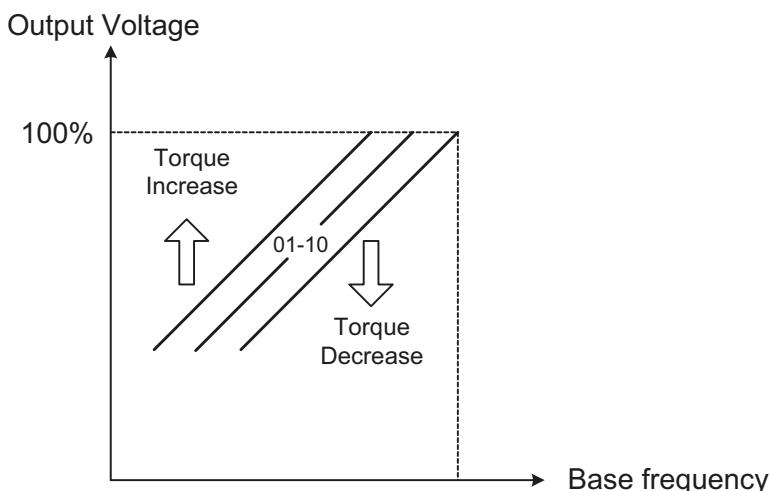
01-11=0: Torque boost mode 0

For use in general applications.

01-11=1: Torque boost mode 1

For use in high speed (120–160Hz) applications where the torque compensation decreases as the frequency increases. When the output frequency is between 0–120Hz the torque compensation amount is the same as when using torque boost mode 0.

Warning: Larger than required torque boost creates over-excitation at low speeds and continued operation may cause motor to overheat.



01-12	Base (nameplate) frequency of motor 1	Default: 50.0/60.0
Range	【4.8–599.0】 Hz	
01-13	Base (nameplate) output voltage of motor 1	Default: 230 or 400
Range	240V: 【0.0–255.0】 V	
	480V: 【0.0–510.0】 V	

Important:

Do not adjust 01-12 to value other than motor specifications. Use parameters 00-12 and 00-13 to limit user accessible frequency range if desired.

01-14	Input Voltage Setting	Default: 230 or 400
Range	240V: 【155.0–255.0】 V	
	480V: 【310.0–510.0】 V	

This parameter is used as a reference for predefined V/F curve calculation (01-00 = 0 through E), over-voltage protection level, stall prevention, etc. If the set value of 01-14 is lower than actual input voltage, the value of output voltage (12-19) and output power (12-07) on the keypad will not be correct.

Set the correct input voltage (200V/208V/230V/240V or 380V/415V/440V/460V/480V).

Note:

Default value of parameter 01-14 depends on the initialization mode selected (13-08).

01-15	Torque compensation time	Default: 200
Range	【0–10000】 ms	

Set the torque compensation delay time in milliseconds.

Only adjust in the following situations:

- Increase the value when experiencing motor vibration.
- Decrease the value when motor torque response is too slow.

01-16	Maximum output frequency of motor 2	Default: 50.0/60.0
Range	【4.8–599.0】 Hz	
01-17	Maximum output voltage of motor 2	Default: 230 or 460
Range	240V: 【0.1–255.0】 V	
	480V: 【0.2–510.0】 V	
01-18	Middle output frequency 2 of motor 2	Default: 0
Range	【0.0–599.0】 Hz	
01-19	Middle output voltage 2 of motor 2	Default: 0
Range	240V: 【0.0–255.0】 V	
	480V: 【0.0–510.0】 V	
01-20	Middle output frequency 1 of motor 2	Default: 3
Range	【0.0–599.0】 Hz	
01-21	Middle output voltage 1 of motor 2	Default: Per Model
Range	240V: 【0.0–255.0】 V	
	480V: 【0.0–510.0】 V	
01-22	Minimum output frequency of motor 2	Default: 1.5
Range	【0.0–599.0】 Hz	
01-23	Minimum output voltage of motor 2	Default: Per Model
Range	240V: 【0.0–255.0】 V	
	480V: 【0.0–510.0】 V	
01-24	Base (nameplate) frequency of motor 2	Default: 50.0/60.0
Range	【4.8–599.0】 Hz	
01-25	Base (nameplate) voltage of motor 2	Default: 230 or 460
Range	240V: 【0.0–255.0】 V	
	480V: 【0.0–510.0】 V	
01-26	V/F Curve of Motor 2	Default: F
Range	【0–FF】	

Note 1:

Motor 2 V/F curve is initially the same as V/f curve of Motor 1. Select the V/F curve for motor 2 using 01-26.

Note 2:

Parameters 01-16–01-25 are changed when a new curve is selected (01-26).

Note 3:

SE01 error will trigger when any Group 01 parameter is out of range or out of order (i.e. a maximum set to a lower value than the corresponding minimum).

02 IM Motor Parameters

02-00	No-load current motor 1	Default: Per Model
Range	【0.01–600.00】 A	
02-01	Rated current motor 1	Default: Per Model
Range	V/F mode is 10%–200% of AC Drive rated current	
	SLV mode is 25%–200% of AC Drive rated current	
02-03	Rated rotation speed motor 1	Default: Per Model
Range	【0–60000】 rpm	
02-04	Rated voltage motor 1	Default: 230.0 or 400.0
Range	240V: 【50.0–240.0】 V	
	480V: 【100.0–480.0】 V	
02-05	Rated power motor 1	Default: Per Model
Range	【0.01–600.00】 KW	
02-06	Rated frequency motor 1	Default: 50.0/60.0
Range	【4.8–599.0】 Hz	
02-07	Number of Motor Poles Motor 1	Default: 4
Range	【2–16】	
02-09	Excitation current motor 1 <1>	Default: Per Model
Range	【15–70】 % motor rated current	
02-10	Core saturation coefficient 1 motor 1 <1>	Default: Per Model
Range	【1–100】 %	
02-11	Core saturation coefficient 2 motor 1 <1>	Default: Per Model
Range	【1–100】 %	
02-12	Core saturation coefficient 3 motor 1 <1>	Default: Per Model
Range	【80–300】 %	
02-13	Core loss motor 1	Default: Per Model
Range	【0.0–15.0】 %	

Motor parameters are automatically set when performing an auto-tune (17-10=1). In most cases no adjustment is required after performing an auto-tune except when using the AC Drive in special applications (e.g. machine tool, positioning, etc....). Please refer to parameter group 22 for permanent magnet motor parameters.

02-00: Motor no-load current

Value is calculated based on the motor rated frequency (17-05) and motor rated current (17-02).

02-01: Motor rated current

The motor rated current parameter protects the motor. Set the motor rated current according to the full load amps (FLA) on the motor nameplate.

1. The value of 02-01 needs to be set to a value greater than the value set in parameter 02-00; otherwise warning message "SE01" out of range error is displayed.
2. In V/F control mode, slip compensation function is active when this output current is greater than the motor no load current.
3. In V/F control mode, the drive output current is greater than the no-load current with slip compensation enabled.

02-03: Rated rotation speed of motor 1

Set the motor rpm according to the motor nameplate.

Note:

Parameter 02-07 "Number of Motor Poles Motor 1" must be set before adjusting parameter 02-03.

02-04: Motor rated voltage

Set the motor rated voltage according to the motor nameplate.

Set the motor rated voltage and it will adjust maximum output voltage of V/F curve.

02-05: Motor rated power

The nominal motor rated capacity is set at the factory. Please verify that the motor name plate data matches the motor rated capacity shown in parameter 02-05.

Range: 0.1 to 600.0 kW (1HP = 0.746 kW)

02-06: Rated frequency of motor 1

Set the motor rated frequency according to the motor nameplate.

02-07: Number of motor poles

Set the number of motor pole according to the motor nameplate.

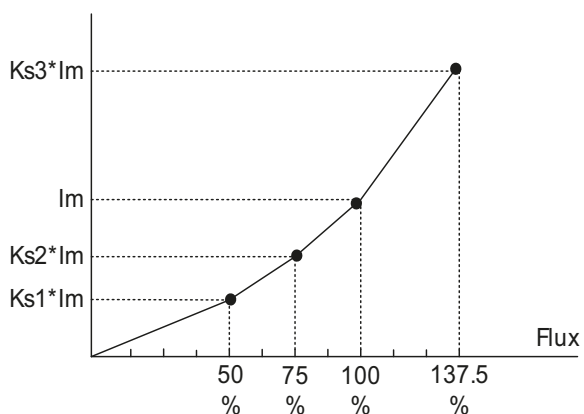
02-09: Motor excitation current

It is not recommended to adjust this parameter. Use caution to when adjusting the Excitation Current.

1. The excitation current is set by performing a rotational auto-tuning. It is required to perform manual tuning if the AC Drive cannot complete a rotational auto-tune.
2. When the manual tuning is performed, start from 33% and observe the no-load voltage (the output value) of parameter 12-07. If parameter 12-07 is higher than no-load voltage set in parameter 17-08, decrease the value of parameter 02-09; if no-load voltage is lower, increase the value for parameter 02-09.
3. Tuning motor excitation current of parameter 02-09 changes the motor leakage inductance of parameter 02-17 and motor mutual inductance of parameter 02-18.
4. It is required to refer to the actual no-load voltage of parameter 12-19 to tune the motor excitation current parameter 02-09. Changing the excitation current affects the no-load voltage fluctuation; adjust parameter 02-09 to a value so the output voltage matches the no-load voltage (17-08).

Setting of motor core's saturation coefficient 1, 2 and 3 (02-10, 02-11, 02-12)

These parameters are automatically set during auto-tune. No adjustment required. Parameters are set to 50% for 02-10, 75% for 02-11 and 137.5% for 02-12 to reduce the impact of core saturation. The motor core's saturation coefficient is defined as a percentage of the motor excitation current. When the motor flux reaches 137.5% level, the core's saturation coefficient must be greater than 137.5%. When the motor flux is 50% or 75%, the core's saturation coefficient must be less than 50% and 75%.



I_m : 02-09 Excitation Current

$Ks1$: 02-10 Motor Core Saturation Coefficients 1

$Ks2$: 02-11 Motor Core Saturation Coefficients 2 $Ks3$: 02-12

Motor Core Saturation Coefficients 3

02-13: Motor core loss

Set motor core loss as the percentage of the motor rated power

$$\%W_{core} (02-13) = \frac{3 \times \text{Motor core loss (watt)}}{\text{Motor rated power (watts, 02-05)}} \times 100\%$$

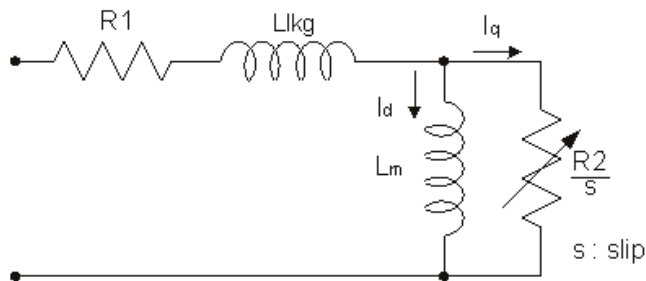
Note:

In V/F mode motor core loss (02-13) is used for torque compensation

02-15	Line-to-line Resistance of motor 1	Default: Per Model
Range	【1–60.000】 Ω	
02-17	Leakage Inductance Motor 1	Default: Per Model
Range	【0.01–200.00】 mH	
02-19	No-Load Voltage of motor 1	Default: Per Model
Range	【0.01–600.00】 A	
02-20	No-Load Current of motor 2	Default: Per Model
Range	【0.01–600.00】 A	
02-21	Rated current of motor 2	Default: Per Model
Range	10%–200% of AC Drive rated current	
02-22	Rated rotation speed of motor 2	Default: Per Model
Range	【0–60000】 rpm	
02-23	Rated voltage of motor 2	Default: 230.0 or 400.0
Range	240V: 【50.0–240.0】 V	
	480V: 【100.0–480.0】 V	
02-24	Rated power of motor 2	Default: Per Model
Range	【0.01–600.00】 KW	
02-25	Rated frequency of motor 2	Default: 50.0/60.0
Range	【4.8–599.0】 Hz	
02-26	Number of Motor Poles of Motor 2	Default: 4
Range	【2–16】	
02-32	Line-to-line Resistance of motor 2	Default: Per Model
Range	【0.001–60.000】 Ω	
02-33	Proportion of Motor Leakage Inductance <1>	Default: Per Model
Range	【0.1–15.0】 %	

02-15: Motor line-to-line resistance

Y-equivalent model of an induction motor



02-19: No-load motor voltage

Parameter determines the rated flux during motor’s rated rotation in SLV control mode. Set the value of this parameter to the same value as parameter 17-08. A value of 10–50V below the input voltage level ensures that the motor is capable of providing adequate torque performance when operating at nominal speed (or higher speed). Setting the value too small can result in a reduction in no-load current, weakened motor flux and an increase in motor current while the motor is loaded.

02-33: Proportion of Motor Leakage Inductance

1. In most applications motor leakage current does not need to be adjusted. The value is not set by the auto-tuning function.

$$\xi = \frac{L_{Kg}}{L_r}$$

2. Leakage inductance proportion is the ratio between leakage inductance and rotor inductance. The default value is set to 3.4%.
3. If the motor leakage inductance proportion value is set too small or too large, it will cause motor jittering, increased motor noise and unable to run the motor. In general the value needs to be between 3.0%–5.0%. 4.0% is the universal adjustment value to allow the motor to run normally. Leakage inductance proportion setting depends on the motor rating.

02-34	Motor Slip Frequency	Default: Per Model
Range	【0.1–20.0】 Hz	

Normally, it is not required for this parameter to be adjusted but can be set manually.

The default value of motor slip is set to 1 Hz. Motor slip is obtained from the nameplate.

Take 60Hz, 4-pole motor for example, synchronous $N = \frac{120 \times \text{Frequency}}{\text{Pole}} = \frac{120 \times 60}{4} = 1800$ rpm speed:

Rated speed in the nameplate is 1700 rpm, $\text{Slip} = \frac{1800 - 1700}{60} = 1.67$ Hz then

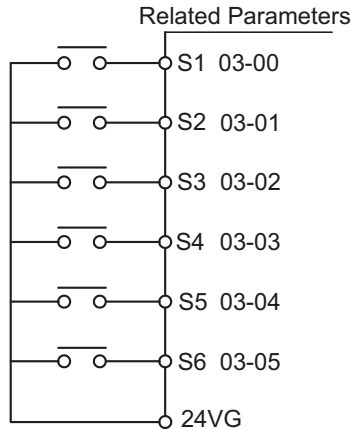
Adjusting motor slip will change the rotor resistance parameter. The motor slip is adjusted depending on the motor performance.

When auto-tuning is successful, parameters of group 2 will be updated with auto-tuning result values refer to group 17 for more details.

03 External Digital Input and Output Parameters

Multi-function digital input and related parameters

Param. #	Parameter Name	Default	Range
03-00	Multifunction Input Terminal S1	0	0: Forward/Stop Command 1: Reverse/Stop Command 2: Multi-Speed/Position Setting Command 1 3: Multi-Speed/Position Setting Command 2 4: Multi-Speed/Position Setting Command 3 5: Multi-Speed/Position Setting Command 4 6: Forward Jog Run Command
03-01	Multifunction Input Terminal S2	1	7: Reverse Jog Run Command 8: UP Frequency Increasing Command 9: DOWN Frequency Decreasing Command 10: Acceleration/ Deceleration Time 2 11: Inhibit Acceleration/ Deceleration Command 12: Main/ Alternative Run Switch Function
03-02	Multifunction Input Terminal S3	2	13: Main/ Alternative Frequency Switch Function 14: Emergency Stop (decelerate to zero and stop) 15: External Baseblock Command (coast to stop) 16: PID Control Disabled 17: Fault Reset 18: Auto Run Mode Enable 19: Speed Search
03-03	Multifunction Input Terminal S4	3	20: Energy Saving 21: Reset PID integral value to Zero 22: Counter Input 23: Counter reset 24: PLC Input 25: Pulse width modulation measurement (S3 only)
03-04	Multifunction Input Terminal S5	4	26: Pulse frequency measure (S3 only) 27: Local/Remote selection 28: Remote mode selection 29: Jog Frequency Selection 33: DC Braking 34: Speed Search 2
03-05	Multifunction Input Terminal S6	17	40: Motor 1/Motor 2 selection 47: Fire mode 48: KEB Acceleration 65: Short-circuit braking 66: PID Control Disable 2 68: External Fault 69: Fire Mode External Overload



Multi-function digital input settings (03-00 to 03-05): “O” Available, “X” Not Available

Value	Function		Description	Control Mode		
	Name	LCD Display		V/F	SLV	PM/SLV
0	Forward/Stop command	2-Wire (FWD-RUN)	2- wire Forward/Stop command (ON: Forward operation command).	<input type="radio"/>	<input type="radio"/>	<input type="radio"/>
1	Reverse/Stop command	2-Wire (REV-RUN)	2- wire Reverse/Stop command (ON: Reverse operation command).	<input type="radio"/>	<input type="radio"/>	<input type="radio"/>
2	Multi-speed/position setting command 1	Multi-Spd/Pos Ref 1	Multi-Speed Reference / Position Reference 1	<input type="radio"/>	<input type="radio"/>	<input type="radio"/>
3	Multi-speed/position setting command 2	Multi-Spd/Pos Ref 2	Multi-Speed Reference / Position Reference 2	<input type="radio"/>	<input type="radio"/>	<input type="radio"/>
4	Multi-speed/position setting command 3	Multi-Spd/Pos Ref 3	Multi-Speed Reference / Position Reference 3	<input type="radio"/>	<input type="radio"/>	<input type="radio"/>
5	Multi-speed/position setting command 4	Multi-Spd/Pos Ref 4	Multi-Speed Reference / Position Reference 4	<input type="radio"/>	<input type="radio"/>	<input type="radio"/>
6	Forward jog run command	FJOG	ON: Forward operation in jog mode (00-18).	<input type="radio"/>	<input type="radio"/>	<input type="radio"/>
7	Reverse jog run command	RJOG	ON: Reverse operation in jog mode (00-18).	<input type="radio"/>	<input type="radio"/>	<input type="radio"/>
8	UP frequency increasing command	UP command	ON: Increase output frequency Function, only active when (Up/Down DOWN command is programmed).	<input type="radio"/>	<input type="radio"/>	<input type="radio"/>
9	DOWN frequency decreasing command	DOWN command	ON: Decrease output frequency (Up/Down Function, only active when ON command is programmed).	<input type="radio"/>	<input type="radio"/>	<input type="radio"/>
10	Acceleration/deceleration time selection	Acc/Decel Time	Acceleration/deceleration time command 1	<input type="radio"/>	<input type="radio"/>	<input type="radio"/>
11	Inhibit Acceleration /deceleration command	ACC/DEC Inhibit	ON: Acceleration/ deceleration prohibition	<input type="radio"/>	<input type="radio"/>	<input type="radio"/>
12	Main/ Alternative Run Switch Function	Run Change Sel	Run Command Source is set in parameter of alternative frequency command (00-03)	<input type="radio"/>	<input type="radio"/>	<input type="radio"/>
13	Main/ Alternative Frequency Switch Function	Freq Change Sel	Frequency Command Source is set in parameter of alternative frequency command (00-06)	<input type="radio"/>	<input type="radio"/>	<input type="radio"/>
14	Emergency Stop (decel. to zero and stop)	E-Stop	ON: Emergency stop active	<input type="radio"/>	<input type="radio"/>	<input type="radio"/>
15	Ext. Baseblock Command (coast to stop)	Ext. BB	ON: Base block active	<input type="radio"/>	<input type="radio"/>	<input type="radio"/>

Value	Function		Description	Control Mode		
	Name	LCD Display		V/F	SLV	PM/SLV
16	PID control disabled	PID Disable	ON: PID control disabled	0	0	0
17	Fault reset (Reset)	Fault Reset	ON: Fault reset	0	0	0
18	Auto Run Mode Enable		ON: Auto run mode enabled (06-00)	-	-	-
19	Speed Search	Speed Search 1	ON: Speed search from the maximum output frequency	0	0	X
20	Energy Saving	Energy saving	ON: Manual energy saving control is based on the settings of 11-12 and 11-18.	0	X	X
21	Reset PID Integral Value to Zero	PID I-Reset	ON: PID integral reset	0	0	0
22	Counter Input	Cnt Input	ON: Counter input by digital input	0	0	0
23	Counter Reset	Cnt Reset	ON: Counter reset by digital input	0	0	0
24	PLC Input	PLC Input	ON: PLC input	0	0	0
25	Pulse Width Measurement (S3)	Pulse Input-Width Measure	ON: Switch to pulse width measurement	0	0	0
26	Pulse frequency Measurement (S3)	Pulse Input-Freq. Measure	ON: Switch to pulse frequency measurement	0	0	0
27	Local/Remote Selection	Local/Remote	ON: Local mode (via the digital operator) OFF: Frequency and operation command will be determined according to the setting of parameter (00-02 and 00-05).	0	0	0
28	Remote Mode Selection	Remote Mode Sel	ON: RS-485 communication control active OFF: Control circuit terminal active	0	0	0
29	Jog Frequency Selection	JOG Freq sel	ON: Jog Frequency Active	0	0	0
33	DC Braking	DC Brake Command	ON: DC braking active	0	0	0
34	Speed Search 2 (From Frequency Command)	Speed Search 2	ON: Speed search from set frequency	0	0	X
40	Motor 1/Motor 2 Selection	Motor 2 Switch	ON: Select motor 2	0	0	X
47	Fire Mode (Forced Operation Mode)	Fire Mode	ON: Fire Mode Active (disables hardware and software fault /alarm protection and runs AC Drive at 08-17 frequency).	0	0	0
48	KEB Acceleration	KEB Accel.	ON:KEB acceleration start enabled	0	0	0
65	Short-Circuit Breaking	SC Brk	ON: Short-Circuit Braking active	X	X	0
66	PID Control Disable 2	PID Disable	ON: PID control disabled	0	0	0
68	External Fault	Ext. Fault	ON: External Fault Alarm	0	0	0
69	Fire Mode External Overload	Ext. Overload	ON: External Overload Input	0	0	0

03-0X =00: 2-wire control forward operation. For more information, see parameter 00-04 details.

03-0X =01: 2-wire control reverse operation. For more information, see parameter 00-04 details.

03-0X =02: Multi-speed/position setting command 1

03-0X =03: Multi-speed/position setting command 2

03-0X =04: Multi-speed/position setting command 3

03-0X =05: Multi-speed/position setting command 4

Multi-speed operation selection

Speed	Multi-function digital input (S1 to S6)*1					Frequency selection
	Jog frequency reference	Multi-speed frequency 4	Multi-speed frequency 3	Multi-speed frequency 2	Multi-speed frequency 1	
0	0	0	0	0	0	Frequency command 0 (05-01) or main speed frequency *2
1	0	0	0	0	1	Frequency command 1 (05-02) *3
2	0	0	0	1	0	Frequency command 2 (05-03)
3	0	0	0	1	1	Frequency command 3 (05-04)
4	0	0	1	0	0	Frequency command 4 (05-05)
5	0	0	1	0	1	Frequency command 5 (05-06)
6	0	0	1	1	0	Frequency command 6 (05-07)
7	0	0	1	1	1	Frequency command 7 (05-08)
8	0	1	0	0	0	Frequency command 8 (05-09)
9	0	1	0	0	1	Frequency command 9 (05-10)
10	0	1	0	1	0	Frequency command 10(05-11)
11	0	1	0	1	1	Frequency command 11 (05-12)
12	0	1	1	0	0	Frequency command 12 (05-13)
13	0	1	1	0	1	Frequency command 13(05-14)
14	0	1	1	1	0	Frequency command 14 (05-15)
15	0	1	1	1	1	Frequency command 15 (05-16)
16	1*1	—	—	—	—	Jog frequency command (00-18)

"0":OFF, "1":ON, "—":Ignore

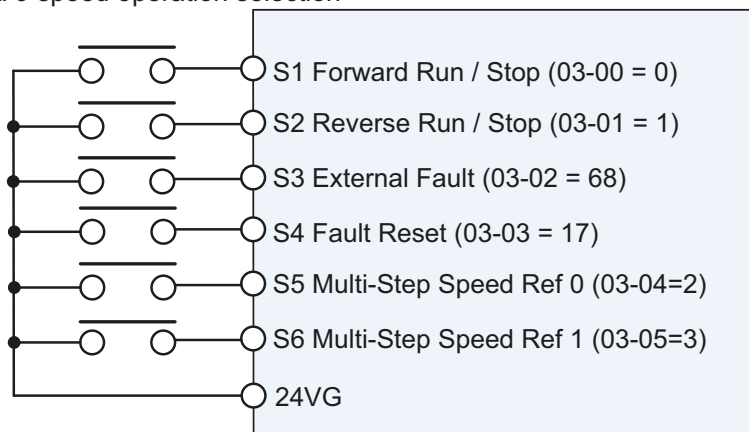
*1: Jog frequency terminal has a higher priority than multi-speed reference 1 to 4

*2: When parameter 00-05=0 (frequency reference input = digital operator), multi-speed frequency 1 will be set by 05-01 (frequency reference setting1). When parameter 00-05=1 (frequency reference input=control circuit terminal), multi-speed frequency command 1 is input through analog command terminal AI1 or AI2.

*3: Multi-speed operation is disabled when PID is enabled or when using External UP/DOWN for main frequency command source.

Wiring Example

Below is an example of a 9 speed operation selection



03-0X =06: Forward jog run command, uses jog frequency parameter 00-18.

03-0X =07: Reverse jog run command, uses jog frequency parameter 00-18.

03-0X =08: UP frequency command

03-0X =09: Down frequency command

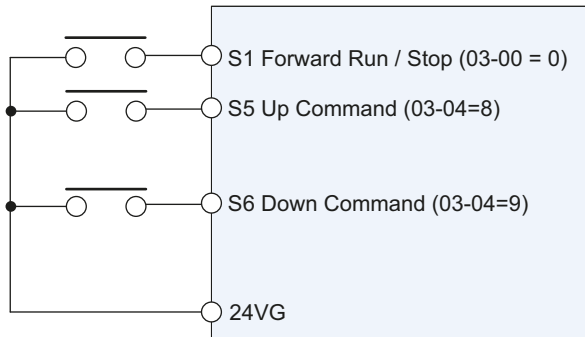
AC Drive can use the digital operator and external digital input (S1–S6) to increase or decrease output frequency while motor is running. To use the external digital inputs to perform UP/DOWN, set 00-02=1, 00-05=4 and 03-0X=8 and 9, this function requires both UP and DOWN functions 08 and 09 to be programmed to two of the digital input terminals.

UP/DOWN frequency command follows the standard acceleration and deceleration times

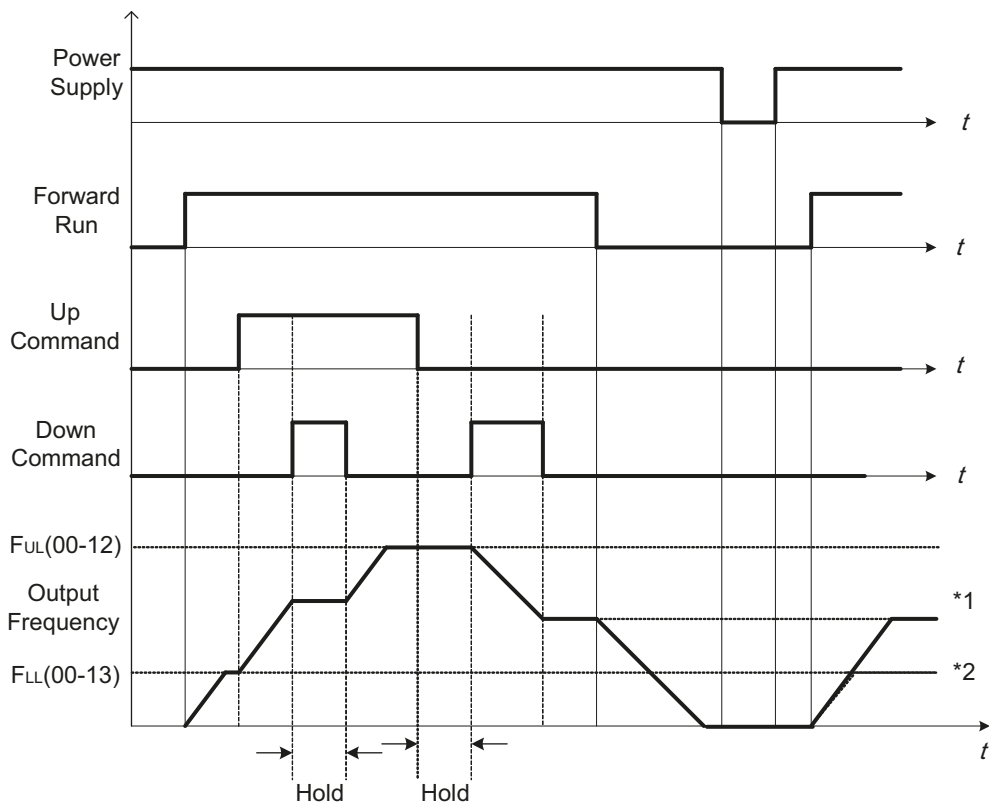
SE02 DI terminal error will be displayed when:

- When only one UP or DOWN command is programmed for the digital inputs.
- When DOWN command and Inhibit Acceleration/deceleration command are active simultaneously.
- When UP command and Inhibit Acceleration/deceleration command are active simultaneously.

For an example of UP/DOWN control wiring and operation, please refer below.



UP Command (Terminal S5)	1	0	0	1
Down Command (Terminal S6)	0	1	0	1
Operation	Accel (UP)	Decel (DWN)	Hold	Hold



UP / DOWN Command Operation

When the Forward Run command is active and the UP or Down command is momentarily activated the AC Drive will accelerate the motor up to the lower limit of the frequency reference (00-13).

When using the UP / Down command, the output frequency is limited to the upper limit of frequency reference (00-12) and the lower limit of frequency reference (00-13).

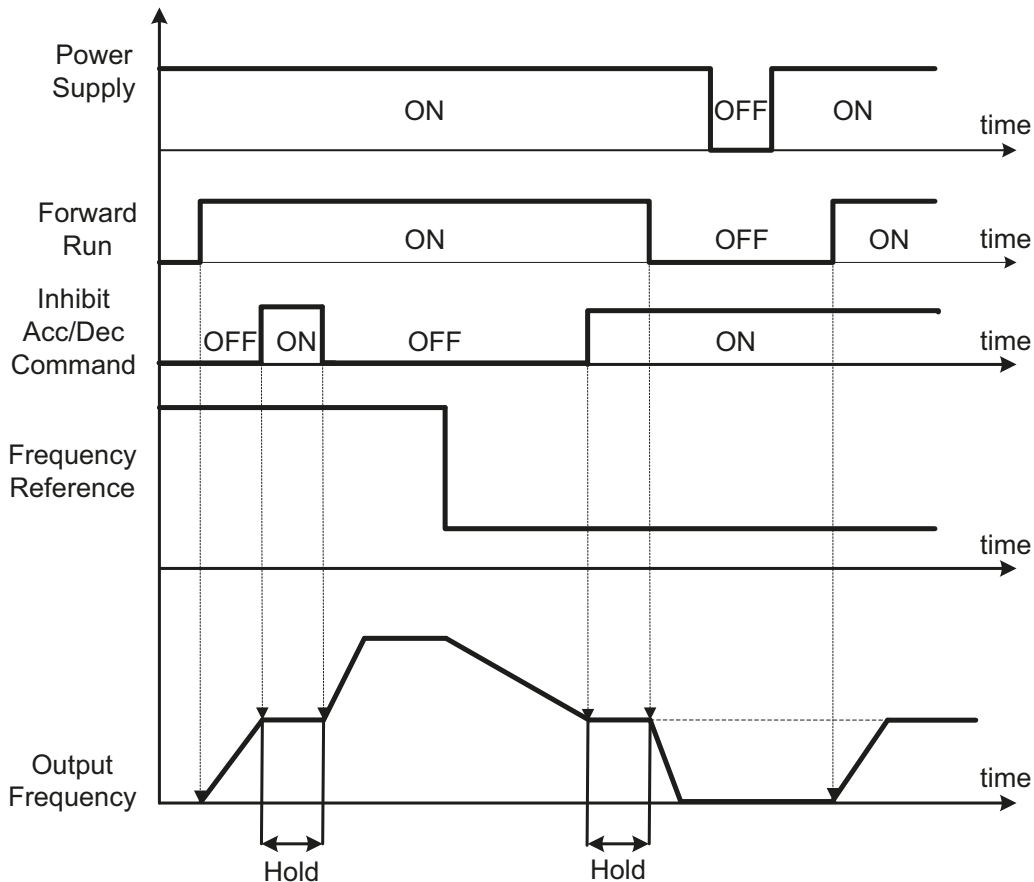
The UP / DOWN command uses acceleration 1 or 2 / deceleration time 1 or 2 for normal operation Tacc1 / Tdec1 (00-14, 00-15) or Tacc2 / Tdec 2 (00-16, 00-17).

03-0X =10: Acceleration/deceleration time selection. Toggle between Acce/Decel. Time 1 and Time 2. (00-14 to 00-17)

03-0X =11: Inhibit Acceleration/deceleration command (hold command)

When activated function suspends the acceleration / deceleration operation and maintains the output frequency at current level. For operation of inhibit Acceleration/deceleration function, please refer to figure below.

The frequency reference value is saved when the acceleration/deceleration inhibit command is active and the frequency reference value is saved even when powering down the AC Drive.



03-0X =12: Main / Alternative Run Switch Function

When active, run command source is set to the alternative run command (00-03).

Note: Digital input function 27 (Local/ Remote control selection) has a higher priority than the main/alternative run switch.

03-0X =13: Main/ Alternative Frequency Switch Function

When active, frequency command source is set to the alternative frequency command (00-06). When PID function is active (10-03=XXX1B), this function is disabled and the frequency reference is set by the PID function. Note: Digital input function 27 (Local/ Remote control selection) has a higher priority than the main/alternative run switch.

03-0X =14: Emergency stop (decelerate to zero and stop)

Refer to the "deceleration time of emergency stop" of parameter 00-26

Emergency stop switch wired to the S terminal that is set to 14 will trigger a deceleration to zero according to the speed set in parameter 00-26 and then stop. Screen will display "ES"

03-0X =15: External Baseblock Command (coast to stop)

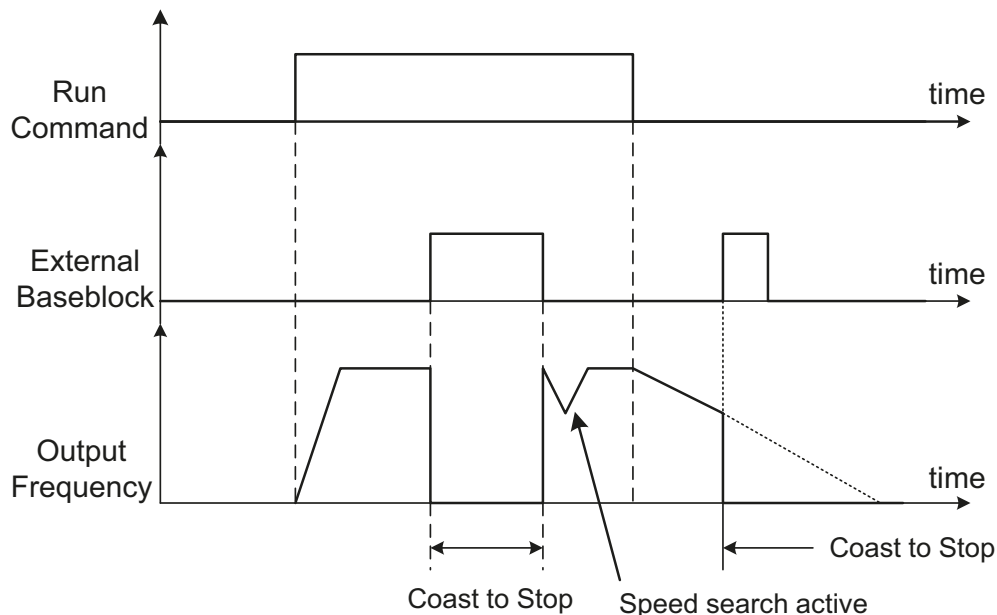
When active the AC Drive output is turned off.

During run: When an external base block command is activated, the keypad displays "BBn BaseBlock (Sn)", indicating the AC Drive output is turned off (n indicates the digital input number 1 – 6). Upon removing the base block signal, the motor will run at the frequency reference. If speed search from frequency reference is active the AC Drive output frequency starts from the frequency reference and searches for the coasting motor speed and continues to operate. If speed search is not active the output frequency starts at 0Hz.

During deceleration: When an external base block command is activated, the keypad displays "BBn BaseBlock (Sn)", indicating the AC Drive output is turned off (n indicates the digital input number 1 – 6). Upon removing the base block signal, the motor is stopped or will coast to a stop and the AC Drive remains in the stop condition.

During acceleration: When an external base block command is activated, the keypad displays "BBn BaseBlock (Sn)", indicating the AC Drive output is turned off (n indicates the digital input number 1 – 6). Upon removing the base block signal, the motor will run at the frequency reference. If speed search from frequency reference is active the AC Drive output frequency starts from the frequency reference and searches for the coasting motor speed and continues to operate. If speed search is not active the output frequency starts at 0Hz.

Please refer to the figure below for external base block operation.



03-0X =16: PID control disabled.

03-0X =17: Fault reset

When the AC Drive trips on a fault the fault output contact is activated, the AC Drive output is turned off (base block) and the keypad displays a dedicated fault message.

The following options are available to reset a fault:

1. Program one of the multi-function digital inputs (03-00 to 03-05) to 17 (reset fault) and activate input.*
2. Press the reset key of the digital operator (RESET).*
3. Cycle power to the AC Drive. Important Note: If a run command is active during power-up, the AC Drive will start running automatically.

Note: To reset an active fault the run command has to be removed.

03-0X =18: Auto run mode enable

When input is active, auto run mode function is enabled. Please refer to group 06 for more information.

03-0X =19: Speed Search 1 (from the maximum frequency). See parameter 07-10 details.

03-0X =34: Speed Search 2 (from the frequency command). See parameter 07-10 details.

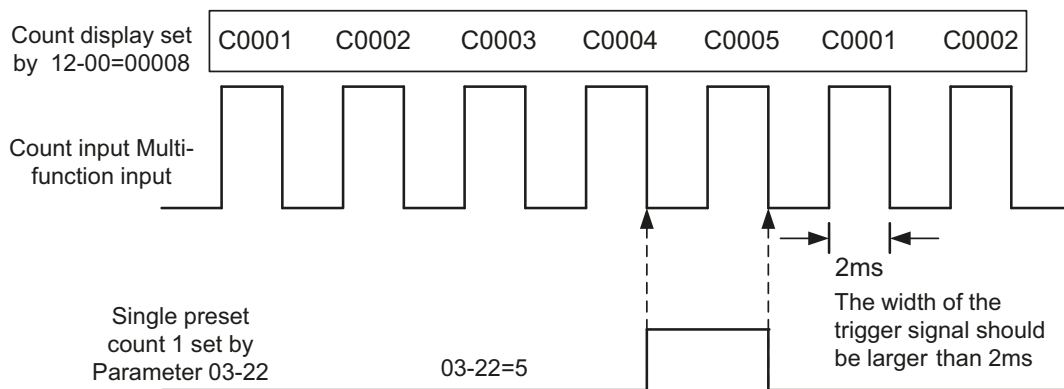
03-0X =20: Energy saving enabled when input is active.

Manual energy savings function is set with parameters 11-12 and 11-18.

03-0X =21: PID integral reset

03-0X =22: Counter Input

When input goes from OFF to ON the counter value increased by '1', Preset Count 1 (03-22) must be set before counter will store instances.



03-0X =23: Counter Reset

When input is active, counter is reset to 0 and the AC Drive display shows "C0000". Deactivate the counter reset input to enable counter.

03-0X =24: PLC Input

When the inputs are set to PLC Input, the AC drive input operation must be programmed using the TD-LINK software. The multi-function inputs will function in accordance to the ladder logic programming downloaded to the AC Drive from the TD-LINK software. Any S terminal input or combination of inputs can be set to PLC function simultaneously.

Note: When writing PLC program to AC drive, the inputs used in ladder logic will be automatically assigned to PLC Input.

Example:

Start button for a machine can be pressed at any time but PLC ladder programming will only recognize that input as active when the machine has finished its startup procedure and is ready to run.

03-02 =25: Pulse Width Measurement

Can only be used for terminal S3 (03-02=25) for pulse width measurement functions.

The following parameters have to be set to use the pulse width function.

00-05=7: Pulse input frequency source

03-02=25: Pulse input width measure

03-31=0.05 – 25 kHz: pulse input frequency

03-32=100.0 – 1000.0%: pulse input gain setting

AC Drive reference frequency= Duty cycle x (00-12) x (03-32) Hz, and below the frequency upper limit

Note: In this mode, the frequency range of pulse input is 0.01 – 0.20 kHz.

Example:

To use the pulse input as a speed reference set the following parameters:
 00=05=7, 03-0X=26, X=0-6 (except select 2), 03-31=pulse input frequency
 03-32=100.0 (adjust as required)

Pulse input frequency is 200Hz, set 03-31=0.20kHz.

Example 1:

Pulse input frequency is 200Hz (03-31=0.20), duty cycle is 50%, frequency upper limit is 50Hz (00-12=50.00), and 03-32=100.0. AC Drive reference frequency is 50% x 50.00=25.00Hz

Example 2:

Pulse input frequency is 200Hz (03-31=0.20), duty cycle is 30%, frequency upper limit is 50Hz (00-12=50.00), and 03-32=200.0. AC Drive reference frequency is 30% x 50.00 x 2=30.00Hz

Example 3:

Pulse input frequency is 200Hz (03-31=0.20), duty cycle is 15%, frequency upper limit is 599Hz (00-12=599.00), and 03-32=500.0. AC Drive reference frequency is 15% x 599.00 x 5.00=499.25Hz

Note:

The examples are based on the digital inputs set for NPN input configuration. To use PNP, the relationship between duty cycle and AC Drive reference frequency is inverted, so 20% duty cycle translates to 80% AC Drive reference frequency.

03-02 =26: Pulse Input Frequency (Can only be used with Terminal S3)

The following parameters have to be set to use the Pulse Input Frequency function.

00-05=7: Pulse with speed control

03-02=26: Pulse input frequency

03-32=100.0 – 1000.0%: pulse input gain setting

AC Drive reference frequency= (Pulse input frequency) x (03-28) Hz, reference frequency limit is the AC Drive frequency upper limit

Example 1:

Pulse input frequency is 20Hz, frequency upper limit is 50Hz (00-12=50.00), and 03-32=100.0, AC Drive reference frequency is 20.00Hz.

Example 2:

Pulse input frequency is 50Hz, frequency upper limit is 50Hz (00-12=50.00), and 03-32=100.0, AC Drive reference frequency is 50.00Hz.

Example 3:

Pulse input frequency is 55Hz, frequency upper limit is 50Hz (00-12=50.00), and 03-32=100.0, AC Drive reference frequency is 50.00Hz.

Example 4:

Pulse input frequency is 599Hz, frequency upper limit is 599Hz (00-12=599.00), and 03-32=20.0, AC Drive reference frequency is 599 x 0.2 = 119.9Hz

Notes:

- Pulse Input frequency range is 0.05–25.00 kHz.
- Only terminal S3 can be used for pulse input.

Digital Inputs configured for PNP: (set switch JP1 to PNP)

The pulse output terminal (Y0) of PLC needs to connect to S3 terminal of AC Drive. The common terminal of the pulse generator (e.g. PLC) output needs to be connected to the +24V terminal of the AC Drive.

Digital Inputs configured for NPN: (set switch JP1 to NPN)

The pulse output terminal (Y0) of PLC needs to connect to S3 terminal of AC Drive. The common terminal of the pulse generator (e.g. PLC) output needs to be connected to the COM terminal of the AC Drive.

03-0X =27: Local / Remote selection.

Switch the AC Drive frequency reference source between Local (keypad) or Remote (control circuit terminals or RS485). Use parameter 00-05 (Main frequency command source selection) and 00-02 (Run command selection) to select the remote source.

Note:

To switch between local and remote the AC Drive has to be stopped.

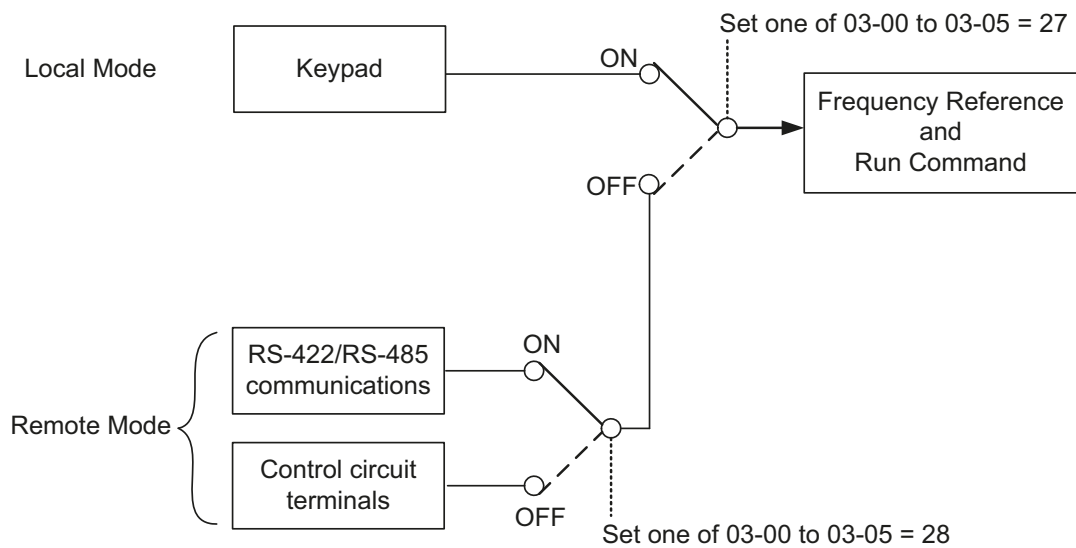
Input	Mode	Frequency Reference / Run/Stop Command Source
ON	Local	- Frequency reference and Run-Stop from keypad. - LEDs SEQ and REF are off.
OFF	Remote	- Frequency reference source selected by parameter 00-05 and Run-Stop source selected by parameter 00-02. - LEDs SEQ and REF are on.

03-0X =28: Local/Remote selection

Switch between terminal source and communication (RS-485) source for frequency reference and operation command.

In Remote mode, indicators of SEQ and REF are on; you can use terminals AI1 and AI2 to control the frequency command, and use terminals S1 and S2 or communication terminal RS-485 to control the operation command.

Input1	Mode	Frequency Reference / Run/Stop Command Source
ON	Communication	- Frequency reference and run/stop command control via communication (RS-422/RS-485).
OFF	Terminal	- Frequency reference source from AI1 / AI2 input (00-05=1) and Run-Stop command from terminals S1 / S2 (00-02=1).

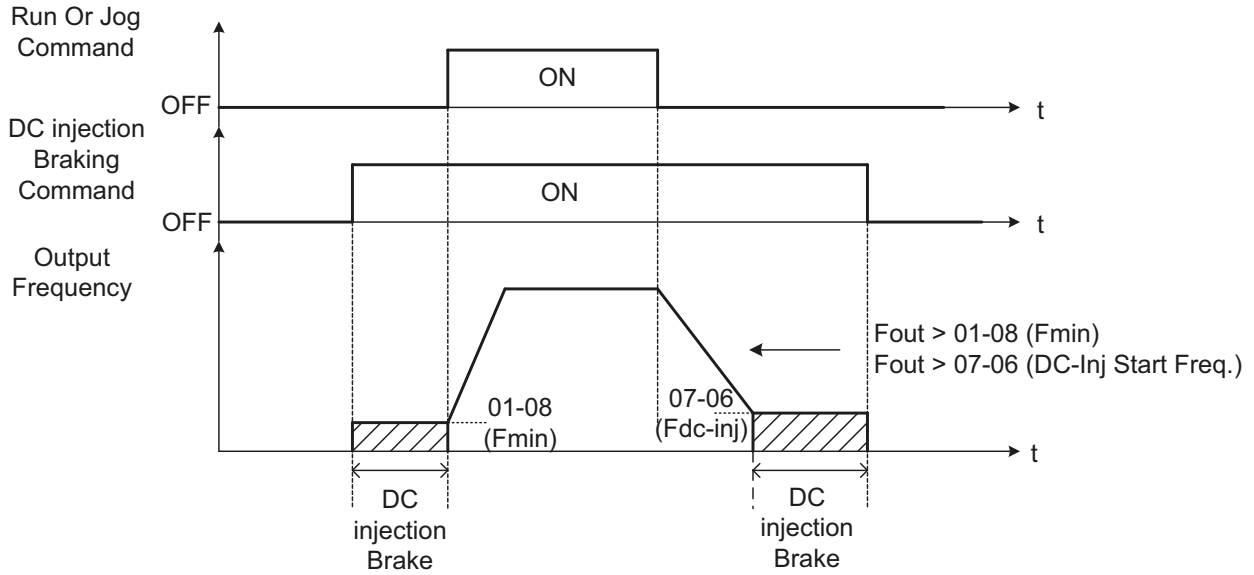


03-0X =29: Jog Frequency Selection

When jog frequency selection is on, the AC Drive will depend on the parameter 00-18 (jog frequency) as the command.

03-0X =33: DC braking

When input is active, DC-Injection braking is enabled during starting and stopping of the AC Drive. DC Injection braking is disabled when a run or jog command is active. Refer to the DC braking time diagram below.



03-0X =34: Speed Search
 Activate speed search function

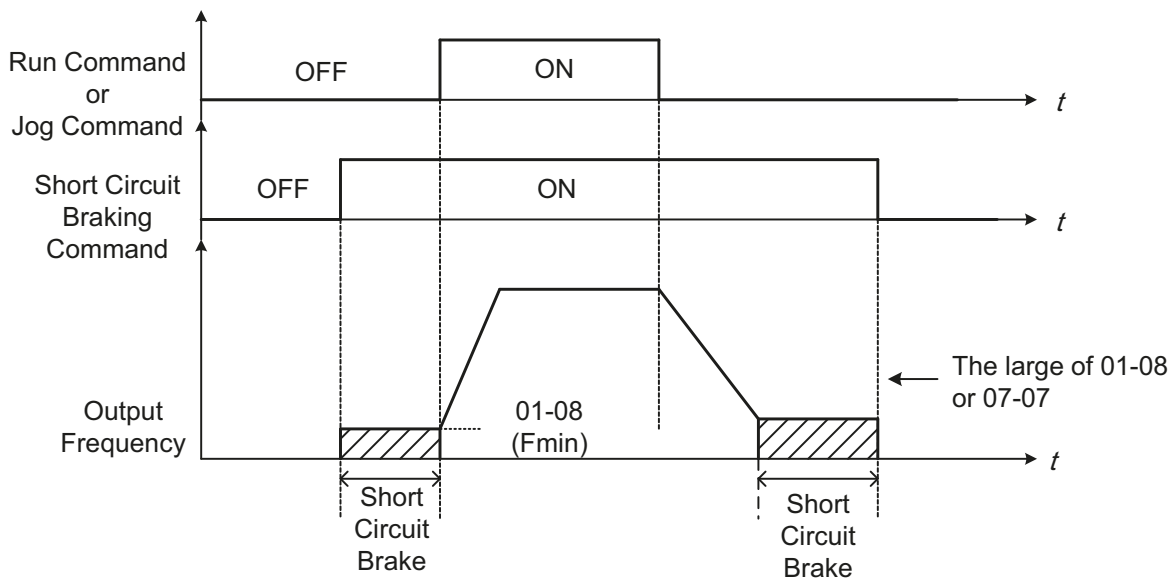
03-0X =40: Motor 2 Selection
 Motor 1 or motor 2 can be selected via the digital input. This function is only available in V/F control mode.

03-05 =47: Fire mode
 Fire Mode must first be enabled with parameter 08-48. When fire mode is enabled 08-48, digital input S6 (03-05) will be locked to function 47. When input is active all AC Drive warning and hardware protections are disabled. This function is commonly used in commercial applications where the AC Drive controls an exhaust fan and needs run to destruction in case of a fire.

03-0X =48: KEB acceleration
 When input is active enables KEB (Kinetic Energy Braking) to accelerate back to the preset frequency after braking. Refer to the parameter description of 11-47 and 11-48 for more details on KEB.
Note: Parameter 11-47 to a value greater than 0 before setting 03-0X=48.

03-0X =65: Short Circuit braking

When active stops AC Drive by turning on Short-circuit braking. Short-circuit braking is disabled when a run or jog



03-0X=66: PID control disabled.

03-0X=68: External Fault

Activating the external fault input will turn off the AC Drive output and the motor will coast to a stop. The keypad displays the external fault message “EFn Ext. Fault (Sn)”, where n is the input terminal number.

03-04=69: Fire Mode External Overload

Fire Mode must first be enabled with parameter 08-48. Used as an input for an external motor overload signal. N.C. = Run. N.O. = Fault. Function 69 is only available for digital input S5 (03-04)

03-0X=70: 2-wire Jog

Allows for a jog command to be used with 2-wire control.

Example:

00-04=1 (Run/Stop-Forward/Reverse)

03-00=0 (2-wire forward operation)

03-01=1 (2-wire reverse operation)

03-02=70 (2-wire JOG control)

S1 frequency command comes from 00-05

S3 frequency command comes from 00-18

S1 and S3 terminal direction can be controlled by S2, the priority of S3 is higher than S1.

03-08	(S1–S6) scan time	Default: 1
Range	1–200 (x2ms)	

Set the digital input CPU scan time. The digital input signal needs to be present for the minimum scan time to qualify as a valid command.

Note:

- For noisy environments select scan time of 8ms (results in a slower response time).
- Scan period unit is 2ms.

03-09	Multi-function terminal S1-S4 type selection	Default: 0000b
Range	xxx0b: S1 A contact xxx1b: S1 B contact xx0xb: S2 A contact xx1xb: S2 B contact x0xxb: S3 A contact x1xxb: S3 B contact 0xxxb: S4 A contact 1xxxb: S4 B contact	

03-10	Multi-function terminal S5-S6 type selection	Default: 0000b
Range	xxx0b: S5 A contact xxx1b: S5 B contact xx0xb: S6 A contact xx1xb: S6 B contact	

Parameter 03-09 and 03-10 selects the digital input type between a normally open and a normally closed switch/contact.

Each bit of 03-09/03-10 represents an input:

03-09= 0 0 0 0 **0:** normally open switch
 s4 **s3** **s2** **s1** **1:** normally closed switch

03-10= 0 0 0 0 **0:** normally open switch
 s6 **s5** **1:** normally closed switch

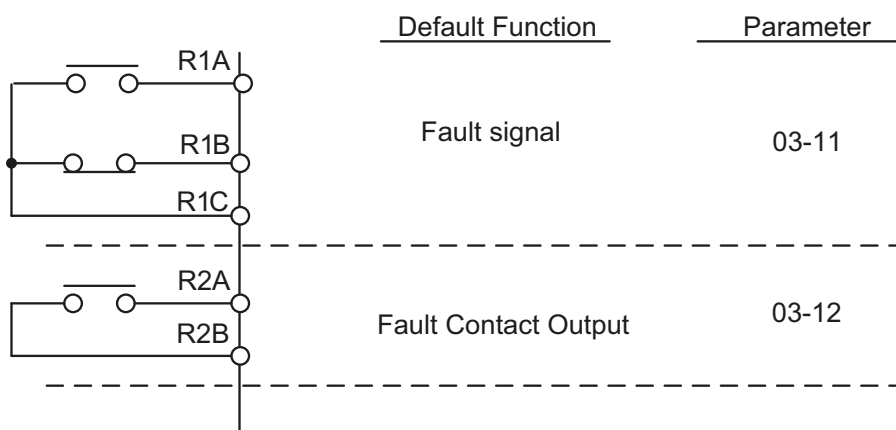
Example: S1 and S2 wired to a normally closed contact / switch set 03-09=0011.



Do not set the operation command parameter 00-02 to terminal control before setting the digital input type. Failure to comply may cause death or serious injury.

Functions of Multi-function Digital Output

Param. #	Parameter Name	Default	Range
03-11	Relay (R1A-R1C) Output	1	【0】 : During Running 【1】 : Fault Contact Output 【2】 : Frequency Agree 【3】 : Setting Frequency Agree (03-13 ± 03-14) 【4】 : Frequency Detection 1 (\geq 03-13, hysteresis range is the setting value of 03-14) 【5】 : Frequency Detection 2 (\leq 03-13, hysteresis range is the setting value of 03-14) 【6】 : Automatic Restart 【7】 : Momentary AC Power Loss 【8】 : Rapid Stop 【9】 : Base Block 【10】 : Motor Overload Protection (OL1) 【11】 : Drive Overload Protection (OL2) 【12】 : Over Torque Threshold Level (OL3) 【13】 : Preset Output Current Reached 【14】 : Brake Control 【15】 : PID Feedback Signal Loss 【16】 : Single Pre-set Count (03-22–03-23) 【17】 : Dual Pre-set Count (03-22–03-23) 【18】 : PLC Status Indicator (00-02) 【19】 : PLC Control 【20】 : Zero Speed 【30】 : Motor 2 Selection 【54】 : Turn On Short-Circuit Braking 【55】 : Low Current Detection 【59】 : OH Detection
03-12	Relay (R2A-R2B) Output	0	【0】 : During Running 【1】 : Fault Contact Output 【2】 : Frequency Agree 【3】 : Setting Frequency Agree (03-13 ± 03-14) 【4】 : Frequency Detection 1 (\geq 03-13, hysteresis range is the setting value of 03-14) 【5】 : Frequency Detection 2 (\leq 03-13, hysteresis range is the setting value of 03-14) 【6】 : Automatic Restart 【7】 : Momentary AC Power Loss 【8】 : Rapid Stop 【9】 : Base Block 【10】 : Motor Overload Protection (OL1) 【11】 : Drive Overload Protection (OL2) 【12】 : Over Torque Threshold Level (OL3) 【13】 : Preset Output Current Reached 【14】 : Brake Control 【15】 : PID Feedback Signal Loss 【16】 : Single Pre-set Count (03-22–03-23) 【17】 : Dual Pre-set Count (03-22–03-23) 【18】 : PLC Status Indicator (00-02) 【19】 : PLC Control 【20】 : Zero Speed 【30】 : Motor 2 Selection 【54】 : Turn On Short-Circuit Braking 【55】 : Low Current Detection 【59】 : OH Detection



Value	Function		Contents	Control mode		
	Name	LCD display		V/F	SLV	PM/SLV
0	During Running	Running	ON:During running (Run command is ON)	○	○	○
1	Fault Contact Output	Fault	ON:Fault contact output (except CF00 and CF01)	○	○	○
2	Frequency Agree	Freq. Agree	ON:Frequency agree (frequency agree width detection is set by 03-14)	○	○	○
3	Setting Frequency Agree (03-13 ± 03-14)	Setting Freq Agree	ON:Output frequency = allowed frequency detection level (03-13) ± frequency bandwidth (03-14)	○	○	○
4	Frequency Detection 1 (≥ 03-13, hysteresis range is the setting value of 03-14)	Freq. Detect 1	ON:Output frequency ≥ 03-13, Hysteresis range is 03-14	○	○	○
5	Frequency Detection 2 (≤03-13, hysteresis range is the setting value of 03-14)	Freq. Detect 2	OFF:Output frequency ≤ 03-13, Hysteresis range is 03-14	○	○	○
6	Automatic Restart	Auto Restart	ON:the period of automatic restart	○	○	○
7	Momentary AC Power Loss	Invalid DO Func.	Reserved	○	○	○
8	Rapid Stop	Invalid DO Func.	Reserved	○	○	○
9	Base Block	Baseblock	ON:During Baseblock	○	○	○
10	Motor Overload Protection (OL1)	Invalid DO Func.	Reserved	○	○	○
11	Drive Overload Protection (OL2)	Invalid DO Func.	Reserved	○	○	○
12	Over Torque Threshold Level (OL3)	Over Torque	ON:Over torque detection is ON	○	○	○
13	Preset Output Current Reached	Current Agree	ON:When output current > 03-15 is ON	○	○	○
14	Brake Control	Invalid DO Func.	ON:Mechanical braking release frequency OFF:Mechanical braking run frequency	○	○	○
15	PID Feedback Signal Loss	Invalid DO Func.	Reserved	○	○	○
16	Single Pre-set Count (03-22 & 03-23)	Invalid DO Func.	Reserved	○	○	○
17	Dual Pre-set Count (03-22 & 03-23)	Invalid DO Func.	Reserved	○	○	○
18	PLC Status Indicator (00-02)	PLC statement	ON:When 00-02 is set to 3 (PLC operation command source)	○	○	○
19	PLC Control	Control From PLC	ON:Control from PLC	○	○	○
20	Zero Speed	Zero Speed	ON:Output frequency < Minimum output frequency (Fmin)	○	○	○
30	Motor 2 Selection	Motor 2 Selection	ON:Switch to Motor 2	○	○	X
37	Detection Output of PID Feedback Loss	Fb	ON:When PID feedback falls below specified level in 10-12	○	○	○
54	Turn On Short-Circuit Braking	SC Brk	ON:Turn on short-circuit braking	X	X	○
55	Low Current Detection	Low Current Detect	ON:Output Current ≤ 03-48 Low Current detection level	-	-	-
59	OH Detection	OH	ON: AC drive temperature > 08-46	-	-	-

03-1X=0: During Running

ON: Run command is ON or output frequency is greater than 0

OFF: Run command is OFF and the AC Drive is stopped.

03-1X=1: Fault contact output

Output is active during fault condition. Communication error (CF00, CF01) does not activate the fault contact.

03-1X=2: Frequency Agree

Output is active when output frequency falls within frequency reference minus the frequency detection width (03-14).

03-1X=3: Setting Frequency Agree

Output is active when the output frequency falls within the frequency detection width (03-14) of the set frequency detection level (03-13).

03-1X=4: Frequency detection 1

Output is active when the output frequency rises above the frequency detection level (03-13) + frequency detection width (03-14) and deactivates when the output frequency falls below frequency detection level (03-13).

03-1X=5: Frequency detection 2

Output is active when the output frequency is below the frequency detection level (03-13) + frequency detection width (03-14) and turns off when the output frequency falls below frequency detection level.

Refer to "Functions of Multi-function Digital Output" table for the operation of frequency detection.

03-1X=6: Automatic restart.

Output is active during an auto-restart operation.

03-1X=7: Momentary AC power loss

Output is active during a momentary AC power loss

03-1X=8: Rapid Stop

Output is active during a rapid stop

03-1X=9: Baseblock (B.B.)

Output is active when the AC Drive output is turned off during a Baseblock command.

03-1X=10: Motor Overload Protection (OL1)

Output is active during motor overload detection (OL1)

03-1X=11: Drive Overload Protection (OL2)

Output is active during AC Drive overload detection (OL2)

03-1X=12: Over torque threshold level (OC3)

Output is active during an over torque detection see parameters 08-13 – 08-16.

03-1X=13: Preset Output Current Reached

When output current > 03-15 for duration > 03-16, output is ON.

03-1X=14: Brake control

Output is active when brake control is active

03-1X=15: PID feedback signal loss

Output is active when PID feedback signal is lost (e.g. wire break)

03-1X=16: Single pre-set count

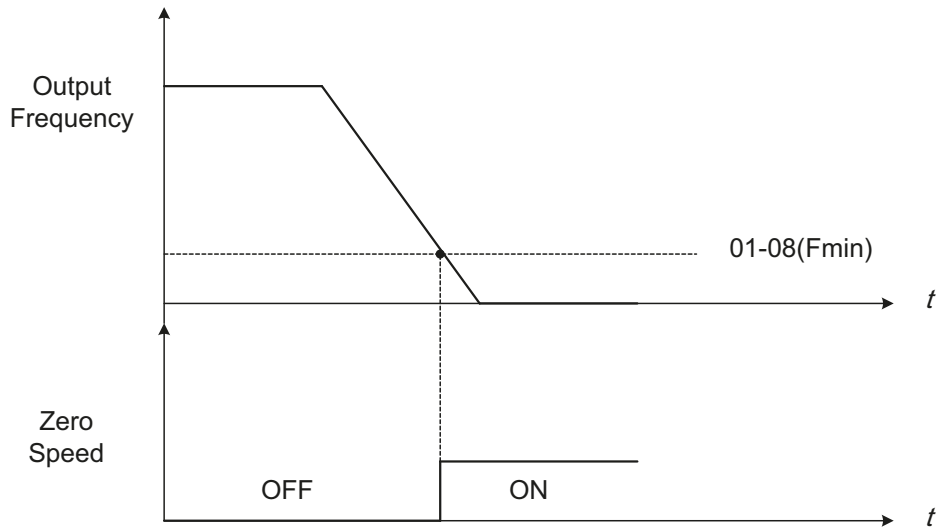
03-1X=17: Dual pre-set count

03-1X=18: PLC status (setting =18)

Output is active when operation command parameter (00-02) is set to 3: PLC Control.

03-1X=19: PLC control contact
Output is controlled by the PLC logic

03-1X=20: Zero-speed
Output is active during zero-speed when output frequency \leq minimum output frequency (01-08).



03-1X=30: Motor 2 Selection
Output is active when motor 2 is selected

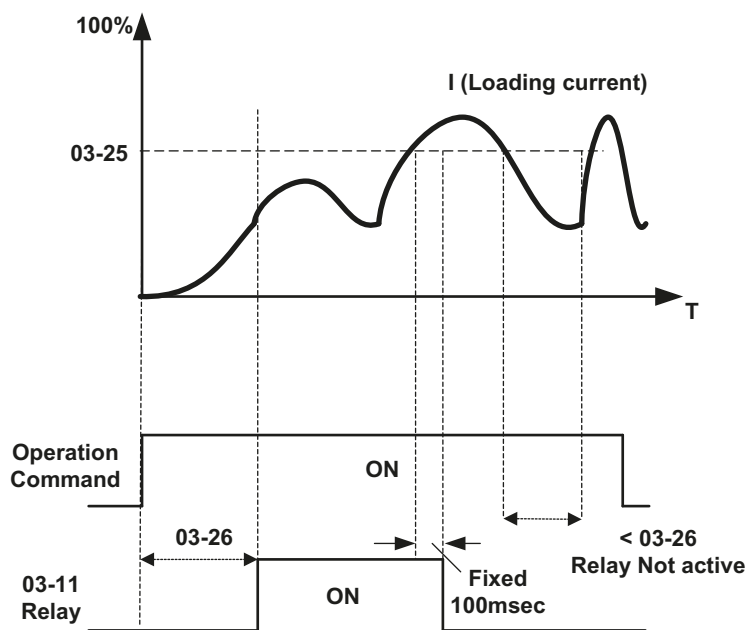
03-1X=37: Detection Output of PID Feedback Loss
Turns ON when PID feedback loss occurs.

03-1X=54: Short Circuit Braking
Output is active during short circuit braking

03-1X=55: Low Current Detection
Relay ON: When output current \leq 03-25 for the time specified in 03-26.
Relay OFF: When output current $>$ 03-25 for the time specified in 03-26.

03-1X=59: Overheat Detection
Relay ON: When AC drive temperature is $>$ 08-46
Relay OFF: When AC drive temperature is $<$ 08-47

Example:



Frequency Agree Detection Functions

03-13	Frequency detection level	Default: 0
Range	【0.0–599.0】 Hz	
03-14	Frequency detection width	Default: 2
Range	【0.1–25.5】 Hz	

Frequency detection Level: set the multi-function output terminals R1A-R1C, R2A-R2C or PH1 (03-11, 03-12) to the desired detection level and bandwidth for use with multi-function output functions 1 to 6.

The time charts for the Frequency Agree Detection operation are shown in the following table.

Function	Frequency Detection Function	Description
Frequency agree		<p>Output is active when the output frequency falls within the frequency reference minus the frequency detection width (03-14).</p> <p>Any of the digital outputs function (03-11, 03-12 or 03-32) can be set to 2 (Frequency agree).</p>
Set frequency agree		<p>Output is active when the output frequency falls within the frequency detection width (03-14) of the set frequency detection level (03-13).</p> <p>Any of the digital outputs function (03-11, 03-12 or 03-32) can be set to 3 (Set frequency agree).</p>

Function	Frequency Detection Function	Description
Output frequency detection 1		<p>Output is active when the output frequency rises above the frequency detection level (03-13) + frequency detection width (03-14) and deactivates when the output frequency falls below frequency detection level (03-13).</p> <p>Any of the digital outputs function (03-11, 03-12 or 03-32) can be set to 4 (Output frequency detection 1).</p>
Output frequency detection 2		<p>Output is active when the output frequency is below the frequency detection level (03-13) + frequency detection width (03-14) and turns off when the output frequency falls below frequency detection level.</p> <p>Any of the digital outputs function (03-11, 03-12 or 03-32) can be set to 5 (Output frequency detection 2).</p>
Frequency Output		<p>Output is active when the AC Drive output frequency is greater than 0.</p>

03-15	Current Agree Level	Default: 0.1
Range	【0.1–999.9】 A	
03-16	Delay Time of Current Agree Detection	Default: 0.1
Range	【0.1–10.0】 Sec	

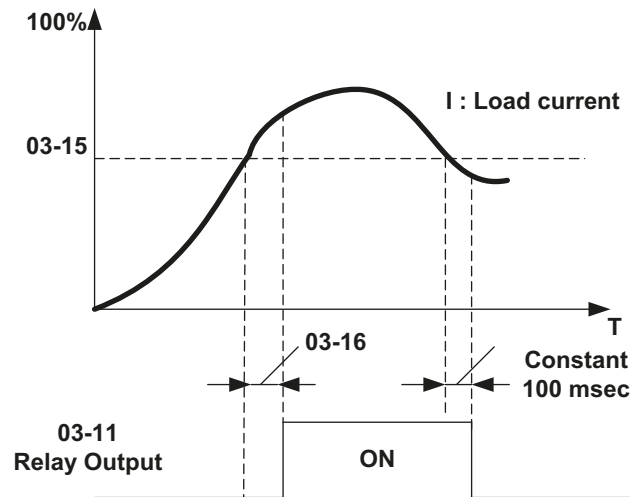
03-11=13: Output is active when the output current > 03-15 for time specified in 03-16.

03-15: Sets the output current detection level.

03-16: Output Current detection delay time

ON: Output current has to rise above specified level (03-15) for time specified in 03-16.

OFF: Output current has to fall below specified level (03-15) for time specified in 03-16.

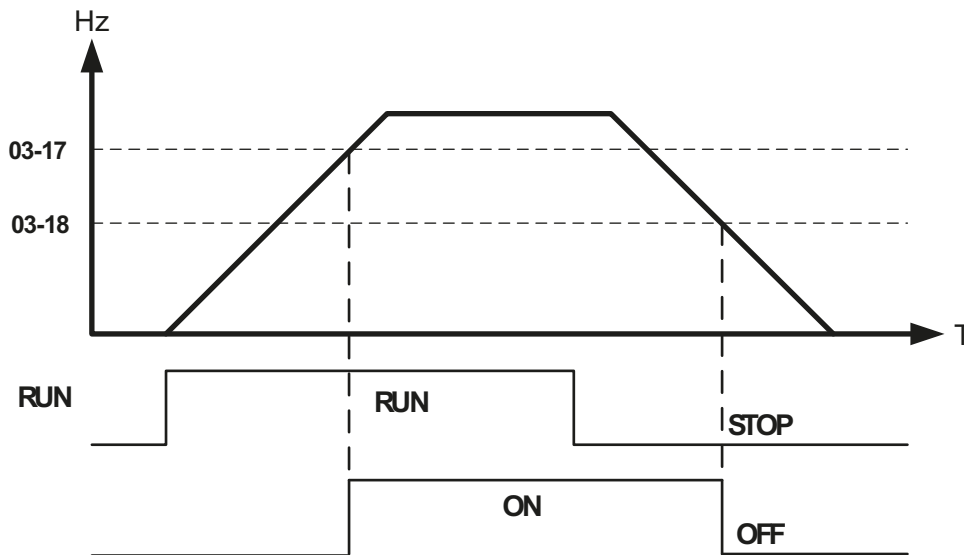


03-17	Mechanical Braking Release Level	Default: 0
Range	【0.00–20.00】 Hz	
03-18	Mechanical Braking Set Level	Default: 0
Range	【0.00–20.00】 Hz	

When 03-11=14, when the output frequency is greater or equal to the value set in 03-18 (Brake Set Level) during acceleration, the relay output will activate.

When 03-11=14, when the output frequency falls below the value set in 03-17 (Brake Release Level) during deceleration, the relay output will de-activate.

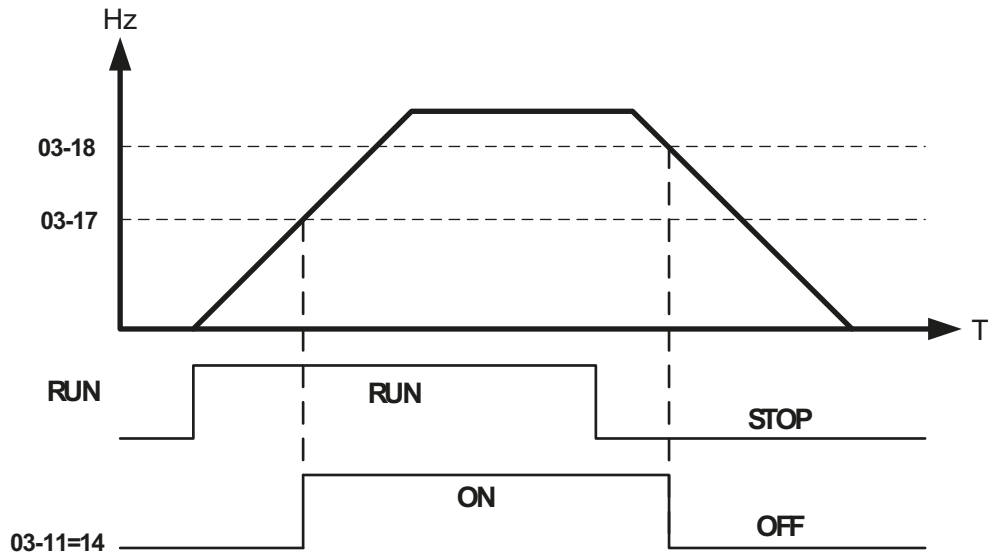
When $03-18 \leq 03-17$, the following sequence applies:



Note:

If the maximum output frequency of motor is over 300Hz, the frequency resolution is changed to 0.1Hz.

When 03-18≥03-17, the following sequence applies:



03-19	Relay (R1A-R2A) Type	Default: 0000b
Range	xxx0b: R1 A contact xxx1b: R1 B contact xx0xb: R2 A contact xx1xb: R2 B contact	

Parameter 03-19 selects the digital output type between a normally open and a normally closed contact.

Each bit of 03-19 represents an output:

03-19 = 0 0 0: normally open contact
 R2 R1 1: normally closed contact

Example:

To have R1 normally open and R2 normally closed, set 03-19=xxx01.

03-20	Internal / External Multi-function Input Terminal	Default: 0
Range	【0-63】	
03-21	Action to Set Internal Multi-function Input Terminals	Default: 0
Range	【0-63】	
03-22	Pre-set Count 1	Default: 0
Range	【0-9999】	
03-23	Pre-set Count 2	Default: 0
Range	【0-9999】	
03-24	Output Under Current Detection	Default: 0
Range	【0】 : Invalid 【1】 : Valid	
03-25	Output Under Current Detection Level	Default: 0.1
Range	【0-999.9】 A	
03-26	Output Under Current Detection Delay Time	Default: 0.01
Range	【0.0-655.35】 Sec	
03-27	UP/DOWN Frequency Hold/Adjust Selection	Default: 0
Range	【0】 : Hold last set frequency when stopped 【1】 : Set frequency to 0 when stopped 【2】 : Allow speed changes from last set frequency when stopped 【3】 : Refresh frequency at acceleration	

03-27=0: When the run command is removed, the External UP/DOWN frequency reference from before deceleration is stored. The next time the run command is applied, the output frequency will ramp up to the previously stored frequency reference. Adjustments to frequency reference can only be made after previously stored reference is reached.

03-27=1: When the run command is removed, the External UP/DOWN frequency reference command is cleared (set to 0). The next time the run command is applied, the output frequency will start at 0.

03-27=2: UP/DOWN command is active when run command is not active.

03-27=3: When the run command is removed, the External UP/DOWN frequency reference from before deceleration is stored. When run command is applied, the output frequency will ramp up to the previously stored frequency reference. Adjustments to frequency reference can be made at any time during run, but before the set frequency is reached.

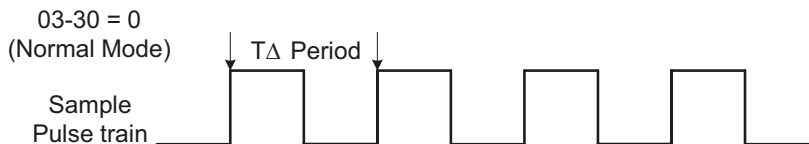
03-30	Pulse Input Selection	Default: 0
Range	【0】 : General Pulse Input 【1】 : PWM	

There are two ways to use the pulse input:

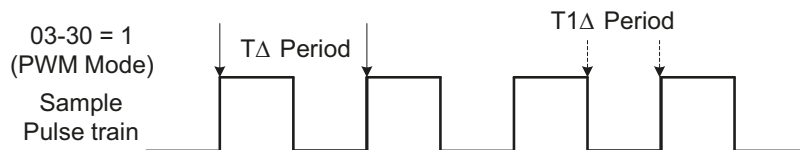
1. Pulse Frequency (Frequency reference = pulse frequency divided by 03-27 x max. frequency (01-02))

2. PWM (Frequency reference = pulse duty cycle (%) x max. frequency (01-02))

Note: The time deviation in PWM mode is $\pm 12.5\%$. If pulse PWM is outside of the deviation range the pulse input is not active.



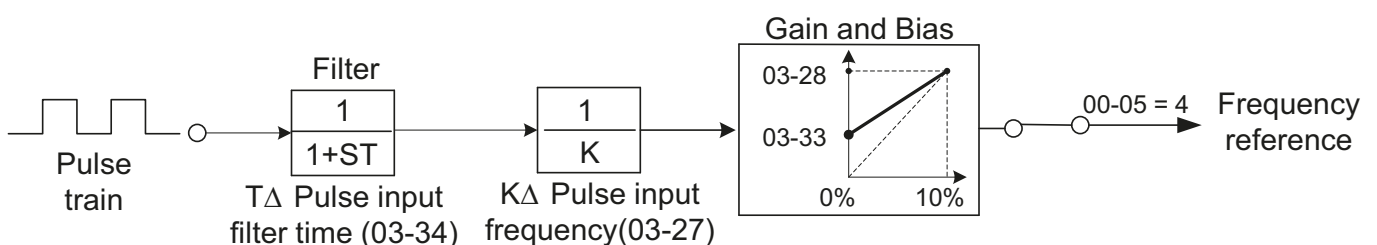
$$F = \frac{1}{T(\text{Period})} \quad \text{Pulse command} = \frac{\text{Frequency}}{\text{Pulse Frequency (03-27)}} \times 100\% (01-02)$$



$$\text{Pulse Input Command} = \frac{T1(\text{Period})}{T(\text{Period})} \times 100\% (01-02)$$

03-31	Pulse Frequency	Default: 1000
Range	【50–25000】 Hz	
03-32	Pulse Input Gain	Default: 100
Range	【0.0–1000.0】 %	
03-33	Pulse Input Bias	Default: 0
Range	【-100.0–100.0】 %	
03-34	Filter Time of Pulse Input	Default: 0.1
Range	【0.00–2.00】 Sec	

* Refer to figure below for the pulse input specification.



Setup Pulse Input as Frequency Reference

Set parameters 00-05 = 4 and 03-30 = 0 to use the pulse input terminal (PI) as the frequency reference source. Next set the pulse input scaling (03-31), enter the pulse input frequency to match the maximum output frequency. Adjust the pulse input filter time (03-34) in case interference or noise is encountered.

03-40	UP/DOWN Frequency Width Setting	Default: 0.00
Range	【0.00–5.00】 Hz	

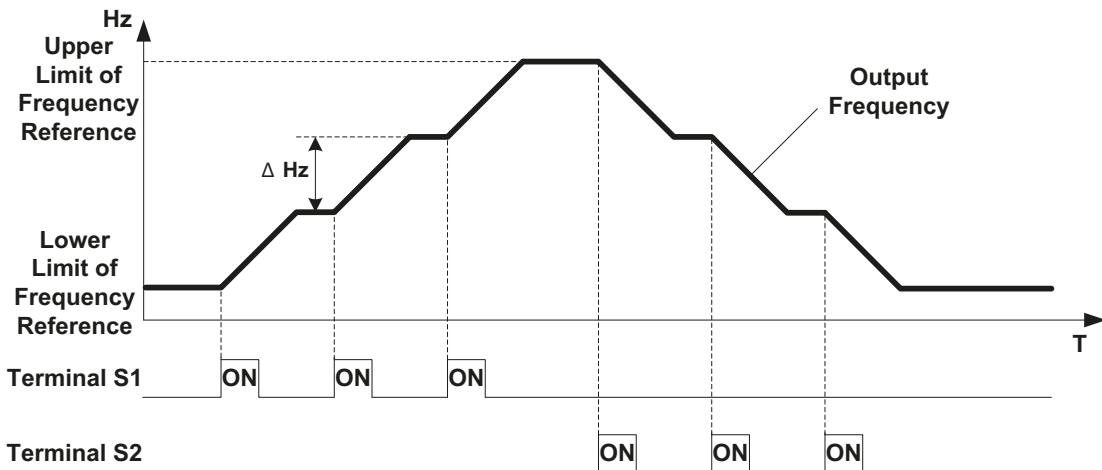
When 03-40=0 Hz, UP/DOWN function is maintained.

When 03-40>0 Hz, frequency command is the run frequency plus the value set in parameter 03-40.

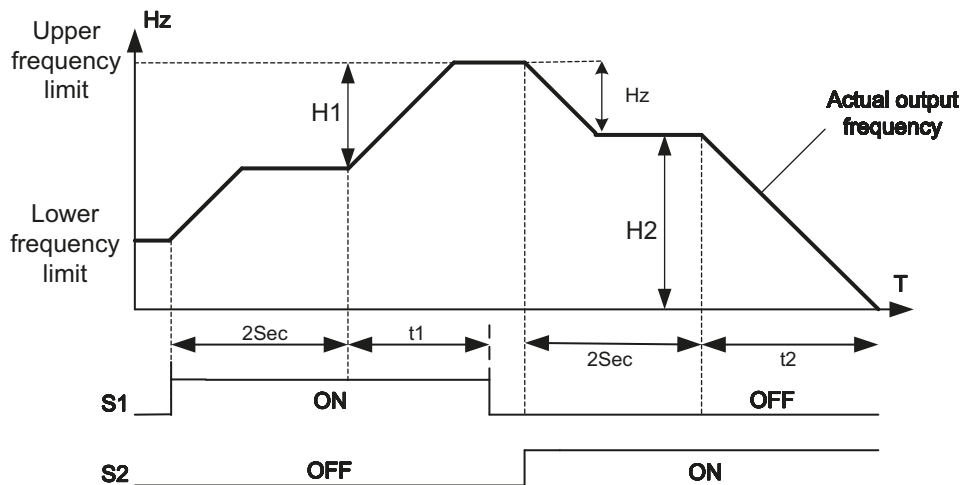
Example: Set terminal S1: 03-00=8 (Up frequency command), terminal S2: 03-01=9 (Down frequency command) and 03-40=ΔHz.

Mode 1: When 03-40=0 Hz, UP/DOWN function is maintained.

Mode 2: When 03-40>0 Hz and multi-function input terminals are active less than 2 sec, frequency change (ΔHz) is based on setting in parameter 03-40.



Mode 3: When 03-40>0 Hz and multi-function input terminals are active for more than 2 sec, frequency changes based upon acceleration / deceleration ramp.



03-53	Current Agree Level 2	Default: 0.0
Range	【0.0–999.9】 A	

03-53: Sets the second output current detection level.

Descriptions:

$\Delta H1$: frequency increase during acceleration, **t1**: Multi-function input active time during acceleration,
 $\Delta H2$: frequency increase during deceleration, **t2**: Multi-function input active time during deceleration.

$$\Delta H1 = \frac{\text{Upper Limit Frequency}}{\text{Acceleration Time 2}} = \text{Multi-function Input Active Time}(t1)$$

$$\Delta H2 = \frac{\text{Lower Limit Frequency}}{\text{Deceleration Time 2}} = \text{Multi-function Input Active Time}(t2)$$

04 Analog Signal Inputs / Analog Output

04-00	Analog Input Signal Type	Default: 1
Range	【0】 : AI1 0–10V / 0–20mA AI2 0–10V / 0–20mA 【1】 : AI1 0–10V / 0–20mA AI2 2–10V / 4–20mA 【2】 : AI1 2–10V / 4–20mA AI2 0–10V / 0–20mA 【3】 : AI1 2–10V / 4–20mA AI2 2–10V / 4–20mA	
04-01	AI1 Signal Scaling and Filter Time	Default: 0.03
Range	【0.00–2.00】 Sec	
04-02	AI1 Gain	Default: 100
Range	【0.0–1000.0】 %	
04-03	AI1 Bias	Default: 0
Range	【-100–100.0】 %	
04-04	AI1 Bias Selection	Default: 0
Range	【0】 : Positive 【1】 : Negative	
04-05	AI1 Slope	Default: 0
Range	【0】 : Positive 【1】 : Negative	
04-06	AI2 Signal Scaling and Filter Time	Default: 0.03
Range	【0.00–2.00】 : Positive	
04-07	AI2 Gain	Default: 100
Range	【0.0–1000.0】 %	
04-08	AI2 Bias	Default: 0
Range	【0–100.0】 %	
04-09	AI2 Bias Selection	Default: 0
Range	【0】 : Positive 【1】 : Negative	
04-10	AI2 Slope	Default: 0
Range	【0】 : Positive 【1】 : Negative	

Analog input signal type (04-00):

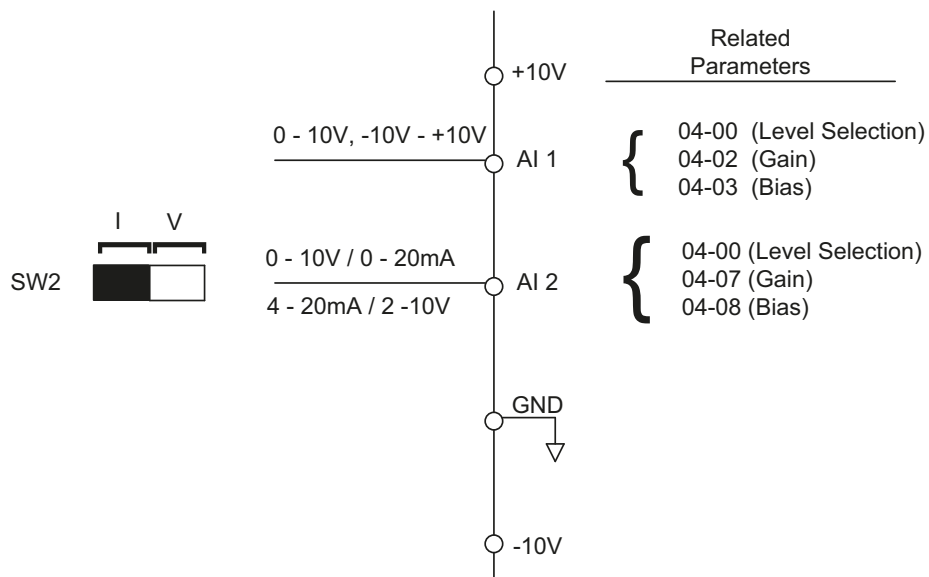
- AI1 is 0–10V, switch JP2 of control board to V, set parameter 04-00 to 0 or 1.
- AI1 is 2–10V, switch JP2 of control board to V, set parameter 04-00 to 2 or 3.
- AI1 is 0–20mA, switch JP2 of control board to I, set parameter 04-00 to 0 or 1.
- AI1 is 4–20mA, switch JP2 of control board to I, set parameter 04-00 to 2 or 3.

- AI2 is 0–10V, switch JP3 of control board to V, set parameter 04-00 to 1 or 3.
- AI2 is 2–10V, switch JP3 of control board to V, set parameter 04-00 to 2 or 4.
- AI2 is 0–20mA, switch JP3 of control board to I, set parameter 04-00 to 1 or 3.
- AI2 is 4–20mA, switch JP3 of control board to I, set parameter 04-00 to 2 or 4.

(1) Analog Input Level Adjustment AI1, AI2 (04-02, 04-03, 04-07, 04-08)

Each analog input AI1 and AI2 has a separate gain and bias parameter associated with it.

Analog input signal AI1 can be adjusted with parameter 04-02 and 04-03; Analog input signal AI2 can be adjusted with parameter 04-07 and 04-08. Refer to figure below.



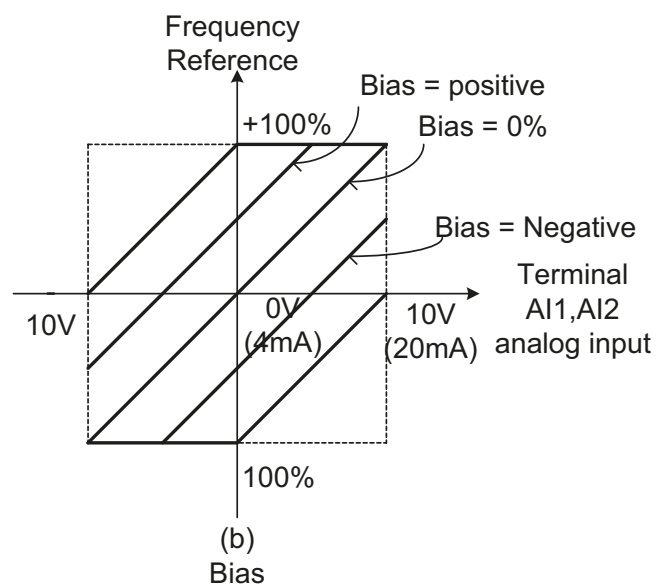
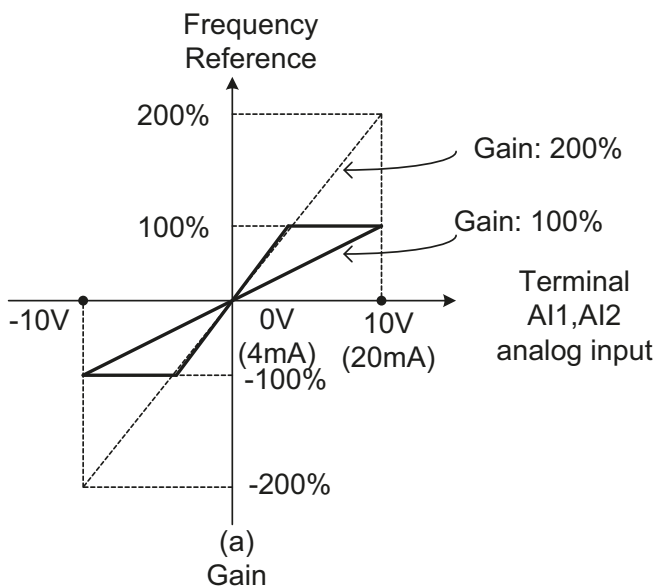
Gain setting: Sets the level in % that corresponds to a 10V, -10V or 20mA signal at the analog input.

(Set the maximum output frequency 01-02 to 100 %)

Bias setting: Sets the level in % that corresponds to a 0V or 4mA signal at the analog input.

(Set the maximum output frequency 01-02 to 100%)

Use both gain and bias setting to scale the input signal.



(2) AI1 signal filtering time (04-01)

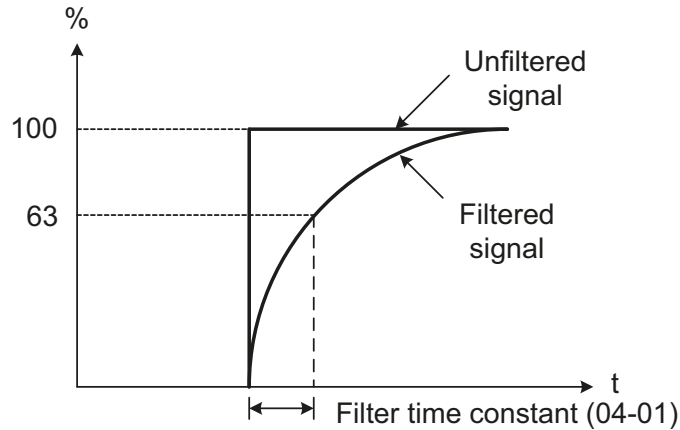
(3) AI2 signal filtering time (04-06)

All analog inputs (AI1, AI2) have a 1st order programmable input filter that can be adjusted when noise is present on each of the incoming analog signal to prevent erratic drive control.

The filter time constant (range: 0.00 to 2.00 seconds) is defined as the time that the input step signal reaches 63% of its final value.

Note:

Increasing the filter time causes the drive operation to become more stable but less responsive to change to the analog input.



04-11	Analog Output (AO) Mode	Default: 0
Range	【0】 : Output frequency 【1】 : Frequency command 【2】 : Output voltage 【3】 : DC voltage 【4】 : Output current	
04-12	AO gain	Default: 100
Range	【0.0–1000.0】 %	
04-13	AO bias	Default: 0
Range	【0.0–100.0】 %	
04-14	AO Bias Selection	Default: 0
Range	【0】 : Positive 【1】 : Negative	
04-15	AO Slope	Default: 0
Range	【0】 : Positive 【1】 : Negative	

Analog output terminal function (04-11)

Please refer to the following table below.

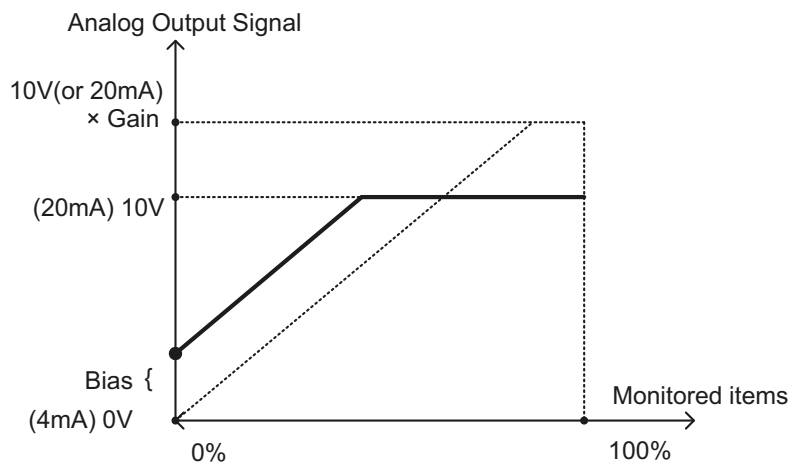
04-11 parameter setting	Function (Keypad display)	Monitoring Parameters 12 Group	Control Mode		
			VF	SLV	PMSLV
0	Output Freq	12-17	○	○	○
1	Freq Ref	12-16	○	○	○
2	Output Voltage	12-19	○	○	○
3	DC Voltage	12-20	○	○	○
4	Output Current	12-06	○	○	○

Analog output AO adjustment (04-12, 04-13 and 04-15)

Signal: Use parameter 04-11 to select the analog output signal for AO.

Gain: Use parameter 04-12 to adjust the gain for AO. Adjust the gain so that the analog output (10V) matches 100% of the selected analog output signal (04-11 for AO).

Bias: Use parameter 04-13 to adjust the bias for AO. Adjust the bias so that the analog output (0V) matches 0% of the selected analog output signal (04-11 for AO).



04-20	AO signal scanning and filtering time	Default: 0
Range	【0.00–0.50】 Sec	

Parameter 04-20 can be used to filter momentary changes in the analog output signal.

Note:

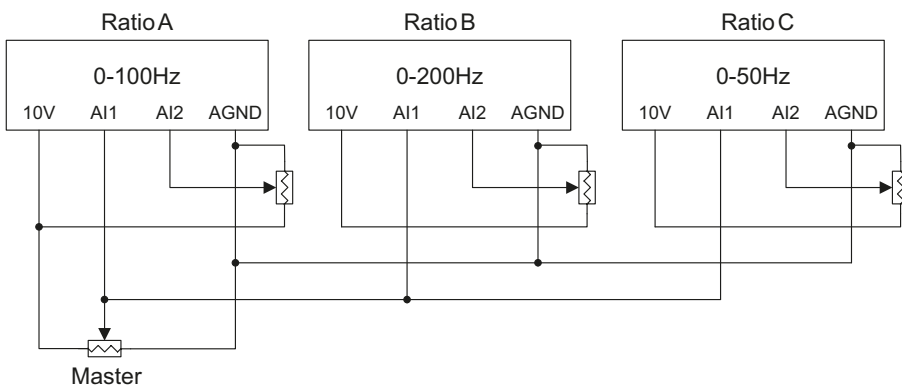
Increasing the filter time results in a slower system response, decreasing the filter time may cause instability of the analog output signal.

04-22	F-Gain	Default: 0
Range	【0】 : Disable 【1】 : Enable	

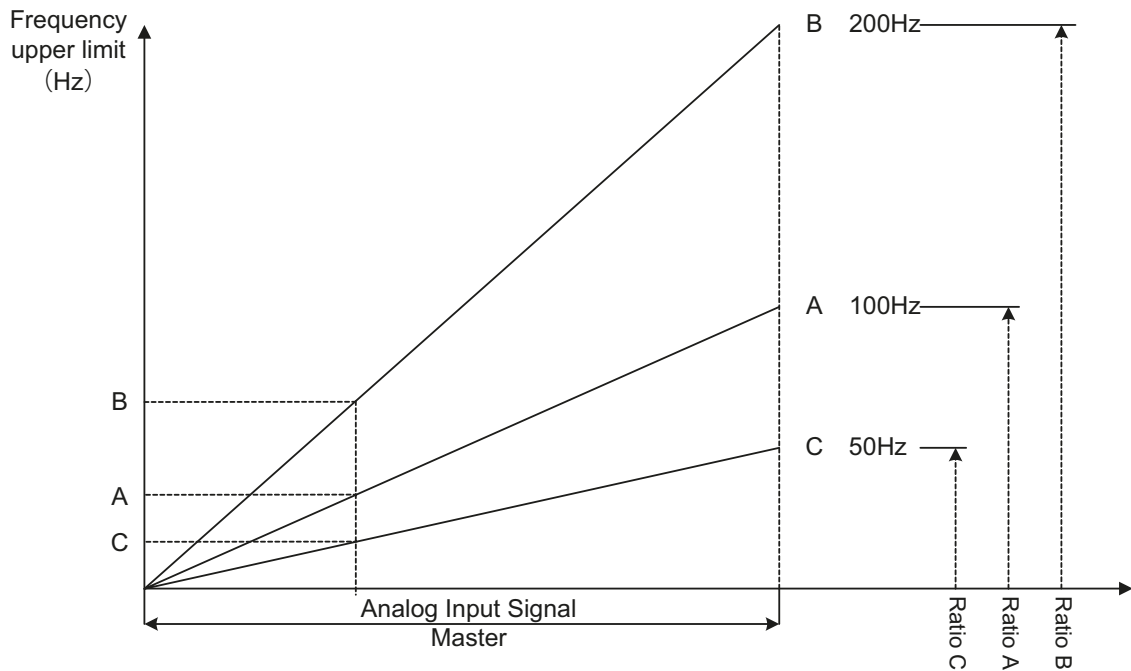
F-Gain Function:

The F- Gain function offers the ability to use a single frequency reference set by a master potentiometer to more than one AC Drive. The master frequency can be scaled by three individual potentiometers for each AC Drive as shown in the diagram below.

To enable set parameter 04-22=1 and set parameter 00-05 =2 (external Analog input AI1). Analog input 2 (AI2) can now be used for external scaling (potentiometer).



A	B	C
00-05=2	00-05=2	00-05=2
00-12=100	00-12=200	00-12=50
04-22=1	04-22=1	04-22=1



04-25	AO Voltage Auto Tuning	Default: 0
Range	【0】 : Disable 【1】 : Enable	

Parameter 04-25 can be used to compensate for inaccuracies in the analog output. These may be caused by voltage drop or impedance mismatch between the AC drive and the other device.

To auto tune the analog output, adjust as follows:

1. Disconnect external equipment and short AI2 and AO together
2. Set 04-25=1
3. Remove short, re-connect external equipment and test if inaccuracy has been corrected.

Note: 04-25 will reset to **【0】** after auto-tuning is complete.

05 Preset Frequency Parameters

05-00	Preset Speed Control mode Selection	Default: 0
Range	【0】 : Acceleration and deceleration time 1 – 4 used. 【1】 : Use independent acceleration and deceleration time for each multi-speed setting.	

Param. #	Parameter Name	Default	Range
05-01	Preset Speed 0 (Keypad Frequency)	5	【0.00 – 599.00】 Hz
05-02	Preset Speed 1	5	
05-03	Preset Speed 2	10	
05-04	Preset Speed 3	20	
05-05	Preset Speed 4	30	
05-06	Preset Speed 5	40	
05-07	Preset Speed 6	50	

Param. #	Parameter Name	Default	Range	
05-08	Preset Speed 7	50	【0.00 – 599.00】 Hz	
05-09	Preset Speed 8	5		
05-10	Preset Speed 9	5		
05-11	Preset Speed 10	5		
05-12	Preset Speed 11	5		
05-13	Preset Speed 12	5		
05-14	Preset Speed 13	5		
05-15	Preset Speed 14	5		
05-16	Preset Speed 15	5		
05-17	Preset Speed 0 Acceleration time	10		【0.1 – 3600.0】 Sec
05-18	Preset Speed 0 Deceleration time	10		
05-19	Preset Speed 1 Acceleration time	10		
05-20	Preset Speed 1 Deceleration time	10		
05-21	Preset Speed 2 Acceleration time	10		
05-22	Preset Speed 2 Deceleration time	10		
05-23	Preset Speed 3 Acceleration time	10		
05-24	Preset Speed 3 Deceleration time	10		
05-25	Preset Speed 4 Acceleration time	10		
05-26	Preset Speed 4 Deceleration time	10		
05-27	Preset Speed 5 Acceleration time	10		
05-28	Preset Speed 5 Deceleration time	10		
05-29	Preset Speed 6 Acceleration time	10		
05-30	Preset Speed 6 Deceleration time	10		
05-31	Preset Speed 7 Acceleration time	10		
05-32	Preset Speed 7 Deceleration time	10		
05-33	Preset Speed 8 Acceleration time	10		
05-34	Preset Speed 8 Deceleration time	10		
05-35	Preset Speed 9 Acceleration time	10		
05-36	Preset Speed 9 Deceleration time	10		
05-37	Preset Speed 10 Acceleration time	10		
05-38	Preset Speed 10 Deceleration time	10		
05-39	Preset Speed 11 Acceleration time	10		
05-40	Preset Speed 11 Deceleration time	10		
05-41	Preset Speed 12 Acceleration time	10		
05-42	Preset Speed 12 Deceleration time	10		
05-43	Preset Speed 13 Acceleration time	10		
05-44	Preset Speed 13 Deceleration time	10		
05-45	Preset Speed 14 Acceleration time	10		
05-46	Preset Speed 14 Deceleration time	10		
05-47	Preset Speed 15 Acceleration time	10		
05-48	Preset Speed 15 Deceleration time	10		

05-00=0: Standard Acceleration and deceleration times parameters 00-14 – 00-17 apply to all preset speeds.

05-00=1: Each multi-speed uses a dedicated acceleration and deceleration time parameters 05-17 – 05-48. There are two different modes for acceleration / deceleration timing when 05-00 is set to 1, see time example on the next page.

Acceleration time calculation formula

$$\text{Time it takes to reach set frequency} = \frac{\text{Acceleration time} \times (\text{set frequency} - \text{output frequency})}{\text{Maximum output frequency}}$$

Deceleration time calculation formula

$$\text{Time it takes to reach set frequency} = \frac{\text{Deceleration time} \times (\text{output frequency} - \text{set frequency})}{\text{Maximum output frequency}}$$

Maximum output frequency:

Parameter 01-00=F, maximum output frequency set by 01-02, 01-00 ≠ F, maximum output frequency determined by V/F curve selected (50.0 / 60.0 / 90.0 / 120.0 / 180.0).

Example: 01-00=0 (50Hz (maximum output frequency), 05-02=10 Hz (multi-step speed 0), 05-17=5.0s (Acceleration time), 05-18=20.0 sec. (Deceleration time).

Acceleration time calculation formula

$$\text{Time it takes to reach set frequency} = \frac{5.0 \times 10 \text{ Hz}}{50 \text{ Hz}} = 1.0 \text{ sec.}$$

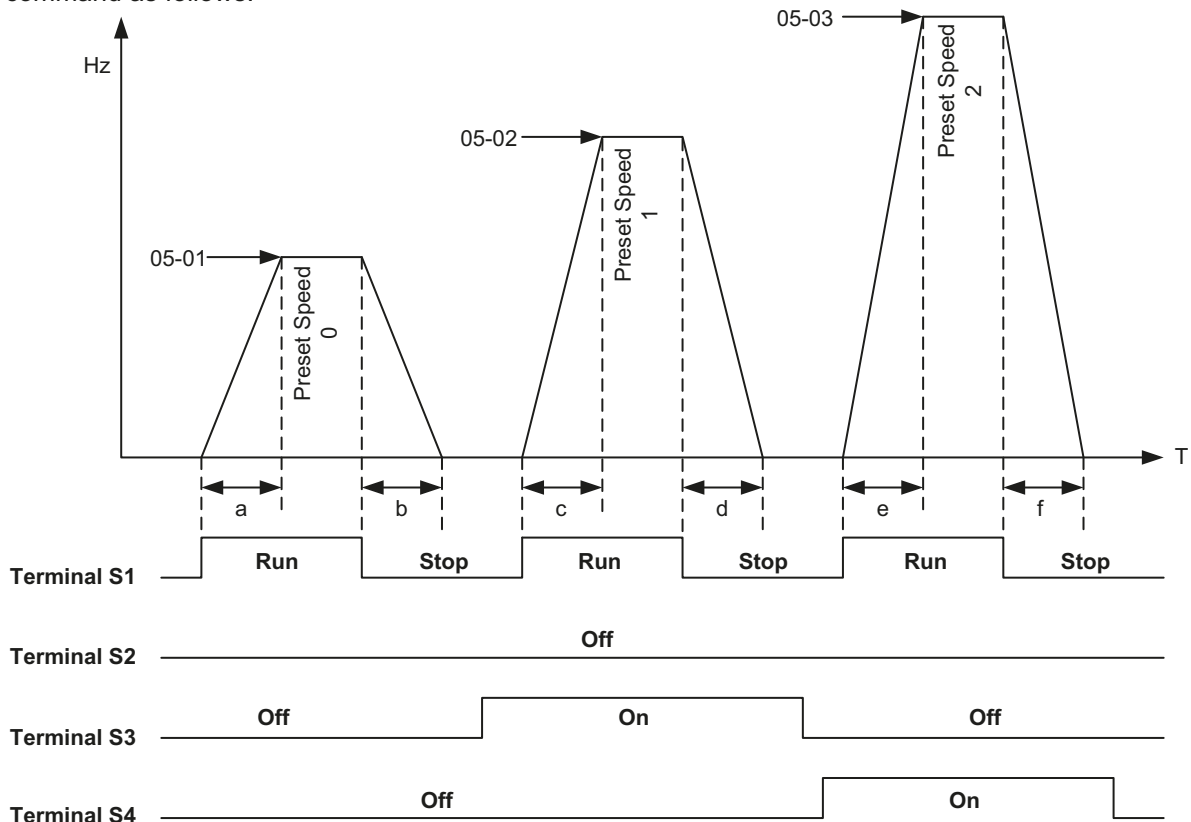
Deceleration time calculation formula

$$\text{Time it takes to reach set frequency} = \frac{20.0 \times 10 \text{ Hz}}{50 \text{ Hz}} = 4.0 \text{ sec.}$$

Example: Acceleration / deceleration timing when 05-00 is set to 1. In this example the following parameters are set:

- 00-02= **【1】** (External Terminal Operation)
- 00-04= **【1】** (Operation Mode: Run/Stop-Forward/Reverse).
- 03-00= **【0】** (Terminal S1: Run /Stop)
- 03-01= **【1】** (Terminal S2: Reversal /Stop)
- 03-02= **【2】** (Terminal S3: Preset Speed 1)
- 03-03= **【3】** (Terminal S4: Preset Speed 2)
- 03-03= **【4】** (Terminal S5: Preset Speed 3)

If the run command is cycled on and off, acceleration and deceleration time (a – f) is calculated based on the active speed command as follows:

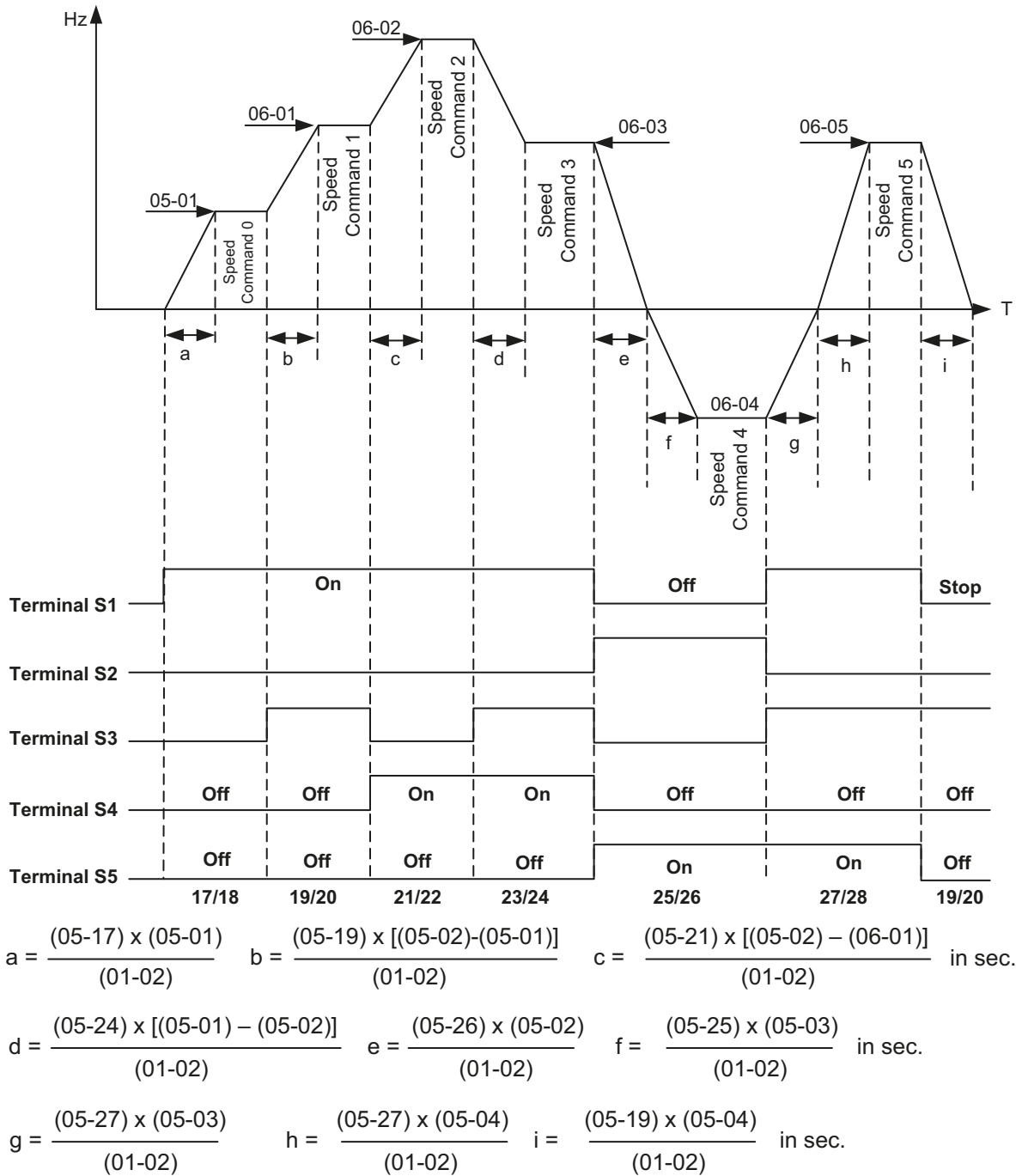


$$a = \frac{(05-17) \times (05-01)}{(01-02)} \quad b = \frac{(05-18) \times (05-01)}{(01-02)} \quad c = \frac{(05-19) \times (05-02)}{(01-02)} \quad \text{in sec.}$$

$$d = \frac{(05-20) \times (05-02)}{(01-02)} \quad e = \frac{(05-21) \times (05-02)}{(01-02)} \quad f = \frac{(05-22) \times (05-03)}{(01-02)} \quad \text{in sec.}$$

Acceleration / Deceleration Calculation Mode 2:

If the run command remains on, acceleration and deceleration time (a – f) are calculated based on the active speed command as follows:



Note:

For parameters 05-01 to 05-16, if the maximum output frequency of motor is over 300Hz, the frequency resolution is changed to 0.1Hz.

06 Automatic Program Operation

06-00	Auto Run Mode Select	Default: 0
Range	<p>【0】 : Disabled</p> <p>【1】 : Execute a single cycle operation. Restart speed is based on the previous stopped speed.</p> <p>【2】 : Execute continuous cycle operation. Restart speed is based on the previous cycle stop speed.</p> <p>【3】 : After completion of a single cycle, the on-going operation speed is based on the speed of the last stage. Restart speed is based on the previous stopped speed.</p> <p>【4】 : Execute a single cycle operation. Restart speed is based on the Speed-Stage 0.</p> <p>【5】 : Execute continuous cycle operation. Restart speed is based on the Speed-Stage 0.</p> <p>【6】 : After completion of a single cycle, the on-going operation speed is based on the speed of the last stage. Restart speed is based on the Speed-Stage 0</p>	

Param. #	Parameter Name	Default	Range
06-01	Frequency setting speed-stage 1	0	【0.00–599.00】 Hz
06-02	Frequency setting speed-stage 2	0	
06-03	Frequency setting speed-stage 3	0	
06-04	Frequency setting speed-stage 4	0	
06-05	Frequency setting speed-stage 5	0	
06-06	Frequency setting speed-stage 6	0	
06-07	Frequency setting speed-stage 7	0	
06-08	Frequency setting speed-stage 8	0	
06-09	Frequency setting speed-stage 9	0	
06-10	Frequency setting speed-stage 10	0	
06-11	Frequency setting speed-stage 11	0	
06-12	Frequency setting speed-stage 12	0	
06-13	Frequency setting speed-stage 13	0	
06-14	Frequency setting speed-stage 14	0	
06-15	Frequency setting speed-stage 15	0	
06-16	Operation time setting speed-stage 0	0	【0.0–6000.0】 Sec
06-17	Operation time setting speed-stage 1	0	
06-18	Operation time setting speed-stage 2	0	
06-19	Operation time setting speed-stage 3	0	
06-20	Operation time setting speed-stage 4	0	
06-21	Operation time setting speed-stage 5	0	
06-22	Operation time setting speed-stage 6	0	
06-23	Operation time setting speed-stage 7	0	
06-24	Operation time setting speed-stage 8	0	
06-25	Operation time setting speed-stage 9	0	
06-26	Operation time setting speed-stage 10	0	
06-27	Operation time setting speed-stage 11	0	
06-28	Operation time setting speed-stage 12	0	
06-29	Operation time setting speed-stage 13	0	
06-30	Operation time setting speed-stage 14	0	
06-31	Operation time setting speed-stage 15	0	

Note:

For parameters 06-01 to 06-16, if the maximum output frequency of motor is over 300Hz, the frequency resolution is changed to 0.1Hz.

Param. #	Parameter Name	Default	Range
06-32	Operation direction speed-stage 0	0	【0】 : Stop 【1】 : Forward 【2】 : Reverse
06-33	Operation direction speed-stage 1	0	
06-34	Operation direction speed-stage 2	0	
06-35	Operation direction speed-stage 3	0	
06-36	Operation direction speed-stage 4	0	
06-37	Operation direction speed-stage 5	0	
06-38	Operation direction speed-stage 6	0	
06-39	Operation direction speed-stage 7	0	
06-40	Operation direction speed-stage 8	0	
06-41	Operation direction speed-stage 9	0	
06-42	Operation direction speed-stage 10	0	
06-43	Operation direction speed-stage 11	0	
06-44	Operation direction speed-stage 12	0	
06-45	Operation direction speed-stage 13	0	
06-46	Operation direction speed-stage 14	0	
06-47	Operation direction speed-stage 15	0	

- Enable Auto Run (sequencer) by setting any of the multi-function inputs S1-S5 (parameters 03-00 to 03-05) to selection 18.
- Various Auto Run (sequencer) modes can be selected with parameter 06-00.
- Auto Run frequency commands 1 to 15 are set by parameters 06-01 – 06-15.
- Sequence run times are set by parameters 06-16 – 06-31.
- FWD/REV Direction for each sequence can be set with parameters 06-32 – 06-47.
- Auto sequence 0, frequency is set from keypad using parameter 05-01; sequence run time and direction are set by parameters 06-16 and 06-32
- Auto run mode uses acceleration parameters 00-14 / 00-15 and deceleration time parameters 00-16 / 00-17.
- In auto run mode, multi-speed frequency references of external signal 1–4 (03-00 to 03-05=2 to 5) are disabled.

Note:

The automatic operation mode is disabled when any of the following functions are enabled:

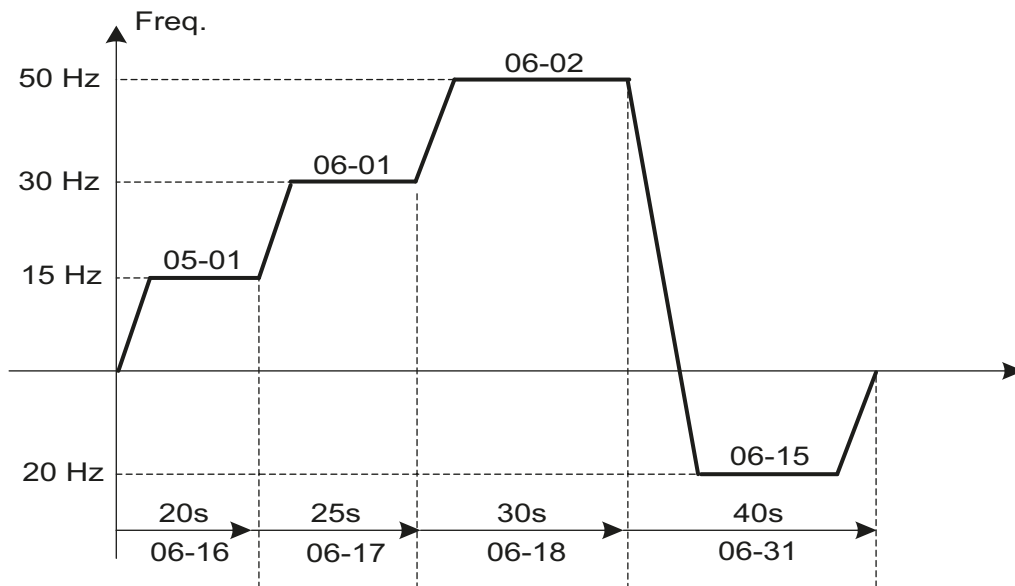
- PID function
- Parameters 06-16 to 06-31 are set to 0.

Example 1: Automatic operation mode – Single cycle

In this example the AC Drive executes a single cycle and then stops.

Parameter Settings:

06-00 =	1 or 4 (Single cycle operation)
06-32–06-34=	1 (Forward for multi-step speed 0 - 2)
06-47=	2 (Reversal for multi-step speed 15)
06-35–06-46=	0 (Stop for multi-step speed 3 - 14)
05-01=	15 Hz (Multi-step speed 0:15 Hz)
06-01=	30 Hz (Multi-step speed 1:30 Hz)
06-02=	50 Hz (Multi-step speed 2:50 Hz)
06-15=	20 Hz (Multi-step speed 15:20 Hz)
06-16=	20 sec (Operation time stage 0:20 sec)
06-17=	25 sec (Operation time stage 0:25 sec)
06-18=	30 sec (Operation time stage 0:30 sec)
06-31=	40 sec (Operation time stage 15:40 sec)

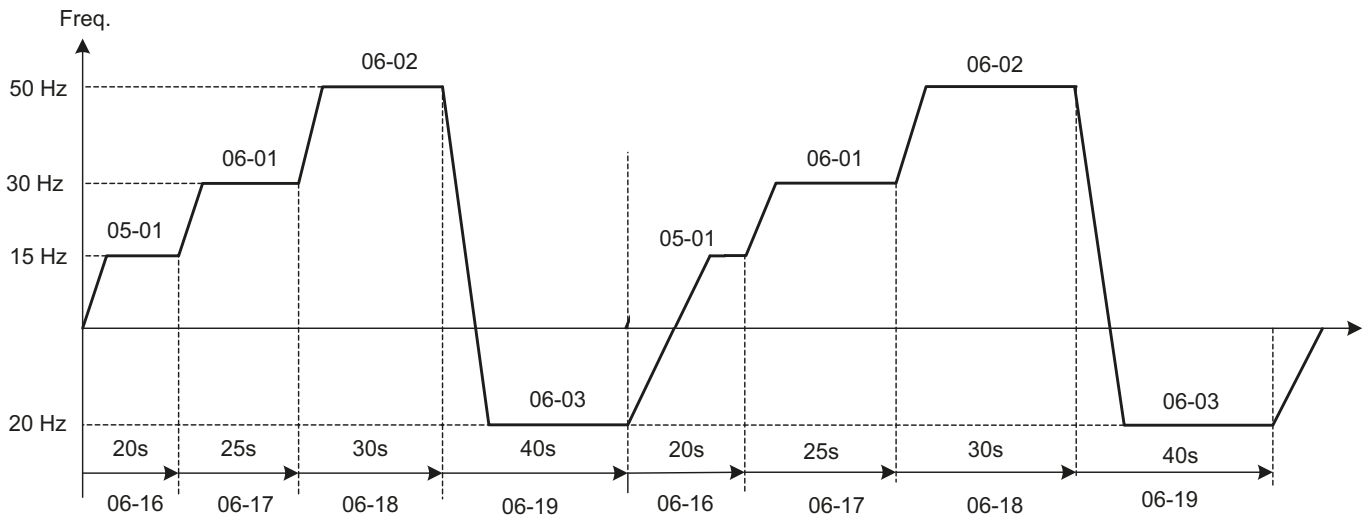


Example 2: Automatic operation mode – Continuous cycle

In this example the AC Drive repeats the same cycle.

Parameter Settings:

06-00 = 2 or 5 (Continuous cycle operation)
 06-01 to 06-47= Enter same setting as that of Example 1.

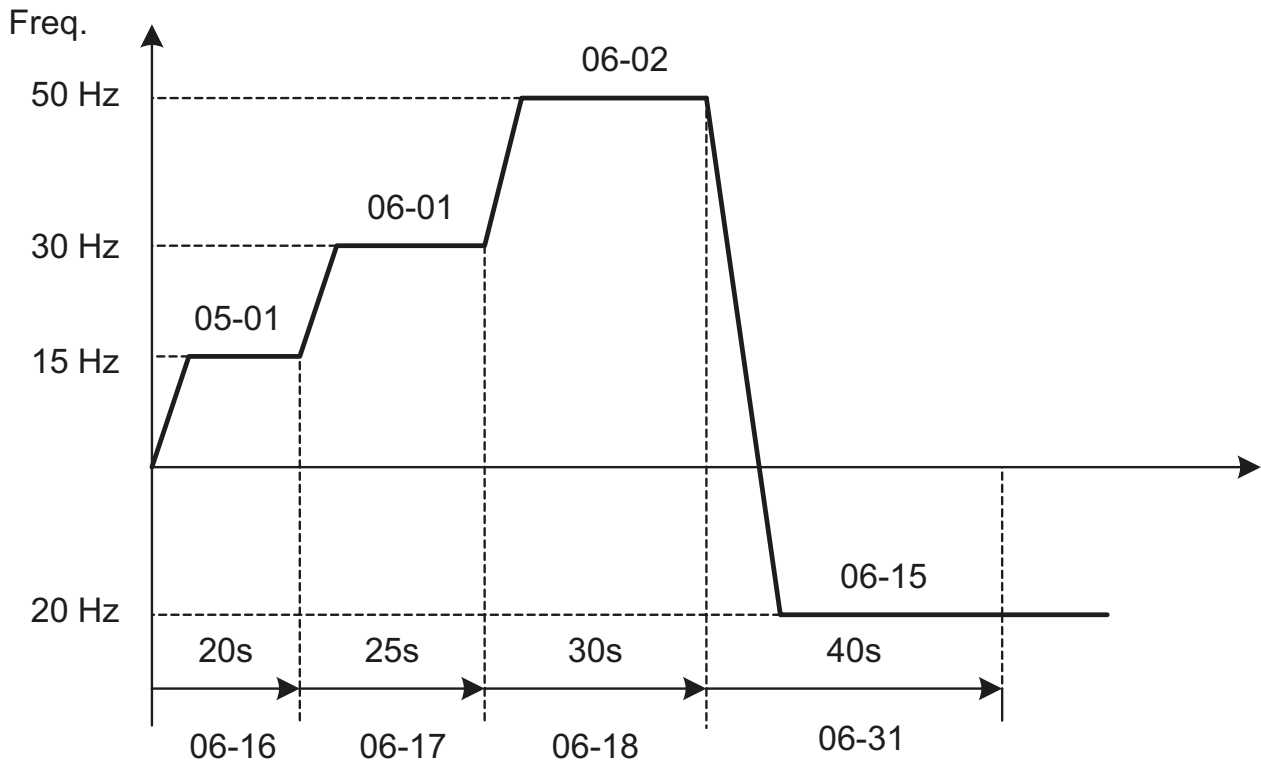


Example 3: Automatic operation mode – Single cycle and continue running at last speed of the cycle

In this example the AC Drive executes a single cycle and continue running at last speed of the cycle.

Parameter Settings:

06-00= 3 or 6 (Single cycle operation)
 06-32 to 06-35= 1 (Forward)
 06-36 to 06-47= 0
 Other parameter = Enter same setting as that of Example 1.

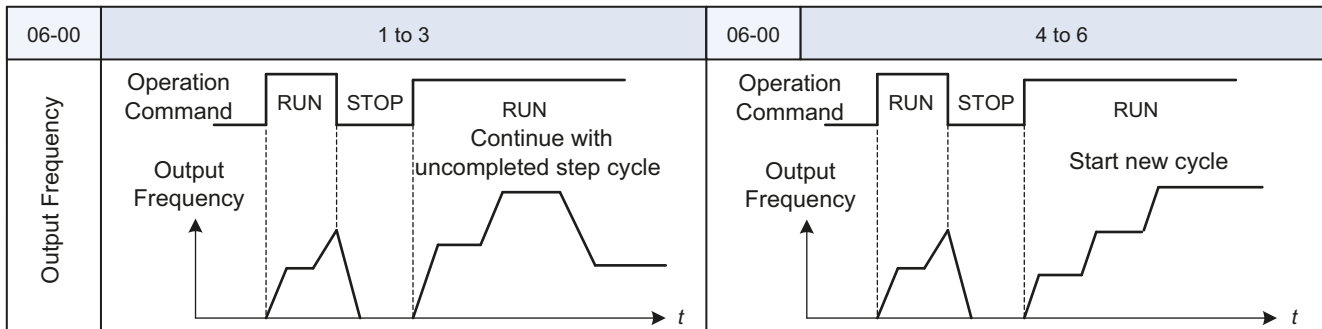


06-00= 1 to 3:

After a stop the AC Drive will start with the incomplete step when run command is re-applied.

06-00= 4 to 6:

After a stop the AC Drive will start with the first step of the cycle when run command is re-applied.

**Notes:**

- ACC/DEC time in Auto run mode will be according to the settings of 00-14 & 00-15.
- When Auto sequence is set to 0, run frequency used is the keypad frequency set by parameter 05-01. Parameters 06-16 and 06-31 are used to set the sequence Run time and Run direction.

07 Start/Stop Parameters

07-00	Momentary power loss and restart	Default: 0
Range	【0】 : Disabled 【1】 : Enabled	
07-01	Fault reset time	Default: 0
Range	【0-7200】 Sec	
07-02	Number of restart attempts	Default: 0
Range	【0-10】	

AC Drive output will be turned off during a sudden drop in input voltage below the under voltage level.

07-00=0: AC Drive trips on “UV” fault on power loss and will not restart.

07-00=1: After power has been restored, AC Drive resumes operation at half of the output frequency before power-loss. There is no limitation on the number of restarts.

The momentary power loss function is enabled as long as the AC Drive CPU still has power. The AC Drive will restart when power is restored based on the setting of parameters 00-02, 07-04 and status of External run command.

Caution: AC Drive will automatically start when power is restored after a power loss and Run mode is set to External Run (00-02=1) and Direct start on power up is enabled (07-04=0).

To ensure safety of operators and to avoid any damages to the machinery, all necessary safety measure must be taken and an AC Drive input disconnect switch must be used.

The automatic restart function can be used for the following faults. Please note that if the fault is not listed in the table, the AC Drive will not attempt an automatic restart.

Fault Code	Description	Number of Restarts
UV:	Under voltage	Unlimited
OC:	Over current	(07-02)
OCA:	Over current during acceleration	(07-02)
OCC:	Over current during constant speed	(07-02)
OCd:	Over current during deceleration	(07-02)
OL1:	Motor overload	(07-02)
UT:	Under torque detection	(07-02)
IPL:	Input phase loss	(07-02)
GF:	Ground fault	(07-02)
OV:	Overvoltage	(07-02)
OL2:	Inverter overload	(07-02)
OT:	Over-torque detection	(07-02)

Note: Auto restart after a fault will not function during DC injection braking or decelerating to stop.

Notes:

- (1) Fault restart function contains momentary power loss restart and auto reset restart.
- (2) Refer to chapter 10 for troubleshooting and fault diagnostics.
- (3) Refer to speed search function (07-19 to 07-24) for speed search modes selection when power is restored.

Fault reset time (07-01)

Time the AC Drive waits to reset fault.

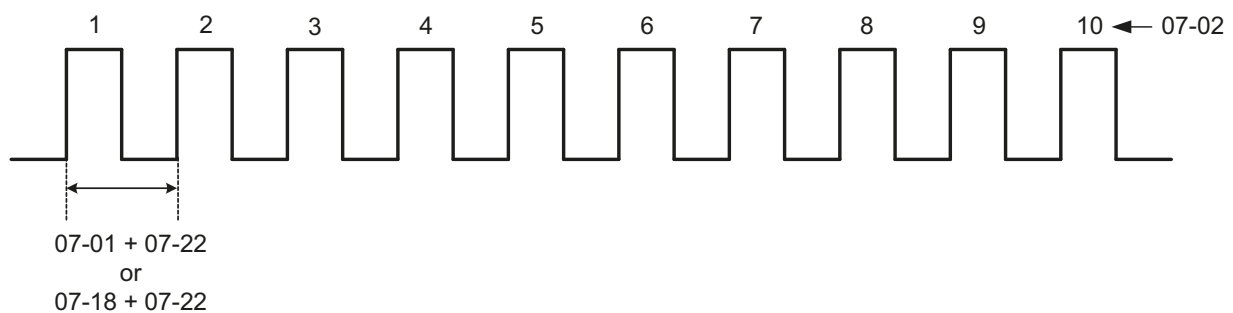
Momentary power loss restart time is the same as Fault reset time.

07-01 < 07-18: Automatic restart time interval is set by minimum baseblock time (07-18).

07-01 > 07-18: Automatic restart time interval is set by fault reset time (07-01).

Note: Total automatic restart interval time is: 07-18 plus 07-01 plus speed search delay time (07-22).

Refer to figure below for automatic restart interval time.



Number of restart attempts (07-02)

When the total number of restart attempts has exceeded the number of automatic restart attempts set in parameter 07-02, the AC Drive will turn off the output and the fault contact is activated. Manually resetting the AC Drive is required at this time.

When the automatic restart function is enabled, the internal automatic restart attempt counter is reset based on the following actions:

- 1.No fault occurs in 10 minutes or longer after the automatic restart
- 2.Reset command to clear fault via input terminal or using the keypad (press STOP/RESET key)
- 3.Power to the AC Drive is turned off and back on again

Note:

Multi-function digital output R1A-R1C, R2A-R2C can be programmed to activate during an automatic reset attempt, refer to parameter 03-11 or 03-12, function 06.

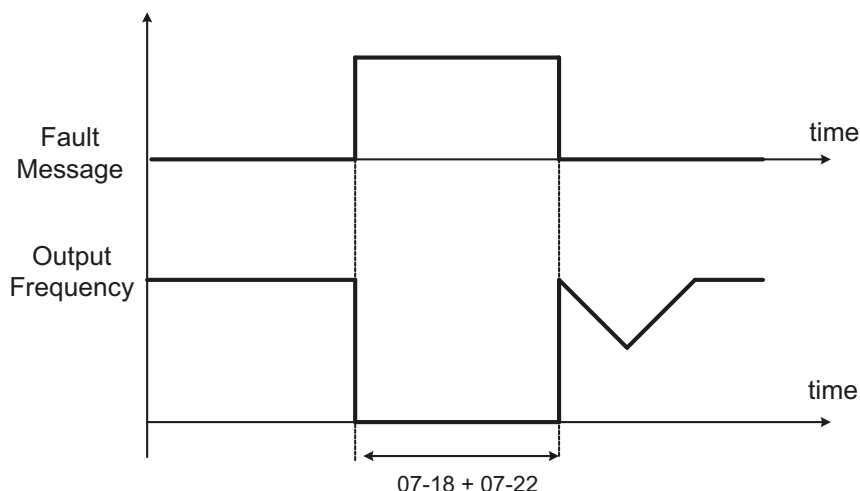
Automatic restart operation:

AC Drive trips and AC Drive output is turned off, keypad shows the active fault. Next, AC Drive waits for the minimum baseblock time parameter 07-18 to expire before accepting an automatic restart command.

After the minimum baseblock time (07-18) and speed search delay time have expired, the active fault is reset and a speed search operation is performed. The time between each fault restart attempt is set by parameter 07-01.

When the total number of restart attempts has exceeded the number of automatic restart attempts set in parameter 07-02, the AC Drive will turn off the output and fault contact is activated. Manually resetting AC Drive is required.

Please refer to figure below for the automatic restart operation.



07-03	Reset Mode Setting	Default: 0
Range	【0】 : Enable Reset Only when Run Command is Off 【1】 : Enable Reset when Run Command is On or Off	

07-03=0 Cycle input run command to reset and restart AC Drive.

Note:

Damage to the AC Drive may occur when the auto restart function is used frequently.

07-04	Momentary power loss and restart	Default: 1
Range	【0】 : Enable Direct Running on Power Up 【1】 : Disable Direct Running on Power Up	
07-05	Delay-ON Timer	Default: 1
Range	【1.0–300.0】 Sec	

When direct run on power up is enabled (07-04=0) and the AC Drive is set to accept an external run command (00-02 / 00-03=1), the AC Drive will automatically start when power is applied and the run switch is ON.

It is recommended to turn off the run switch when power to the AC Drive is turned off to avoid possibility of injury to operators and damage to machines when power is re-applied to the AC Drive.

Note:

If use of this mode is required, all safety measures must be taken to ensure safe operation, including adding and posting warning labels.

When direct run is disabled (07-04 =1) and the AC Drive is set to accept an external run command (00-02 / 00-03=1), the AC Drive will not start when power is applied. In this condition the display will flash with STP1. To start the AC Drive turn the run switch to OFF and back ON again.

07-06	DC Injection Braking Start Frequency	Default: 1.5
Range	【0.0–10.0】 : Hz	

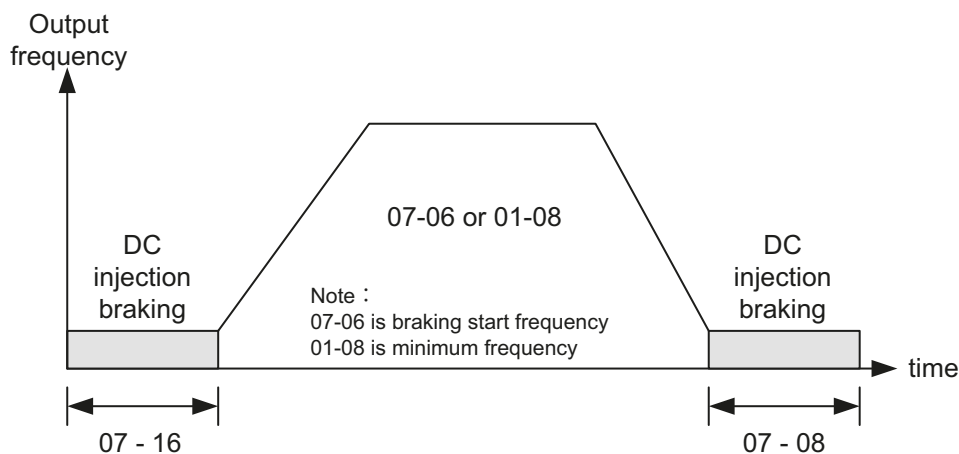
DC Injection braking functionality depends on the selected control mode (00-00), please refer to the description below for each control mode.

V/f or SLV Control mode (00-00 = 0, 2):

DC Injection Brake Start Frequency parameter (07-06) is the level the output frequency has to reach before DC braking injection function is de-activated at start and activated at stop.

DC Injection Brake Level (07-07) is set as percentage of the AC Drive rated current. Increasing this level will increase the amount of heat generated by the motor windings. Do not set this parameter higher than the level necessary to hold the motor shaft.

DC Injection Brake Time at Stop (07-08) specifies the time DC injection braking is active during a stop operation. DC injection braking at stop is disabled when parameter 07-08 is set to 0 sec.



Note:

When 07-06 < 01-08, DC injection braking starting frequency becomes frequency set in parameter 01-08.

PMSLV Control Mode (00-00=5):

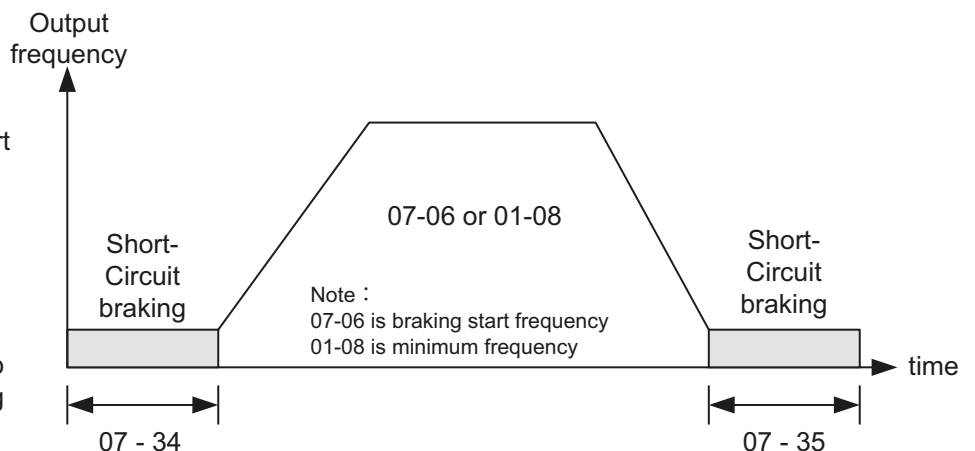
Short-circuit braking is available only in this control mode and functions by switching the IGBTs to produce braking torque.

Short Circuit Braking Start Frequency parameter (07-06) is the level the output frequency has to reach before Short Circuit Braking function is de-activated at start. The same level is used to activate Short Circuit Braking when the output frequency falls below this level.

DC Injection Brake Level (07-07) is set as percentage of the AC Drive rated current. Increasing this level will increase the amount of heat generated by the motor windings. Do not set this parameter higher than the level necessary to hold the motor shaft.

Start Short-circuit Braking Time (07-34) specifies the time short-circuit braking is active at start. Short Circuit Braking at stop is disabled when parameter 07-34 is set to 0 sec.

Stop Short-circuit Braking Time (07-35) specifies the time short-circuit braking is active during a stop operation. Start Short-circuit Braking Time at stop is disabled when parameter 07-35 is set to 0 sec.



Note:

- When 07-06 < 01-08, DC injection braking starting frequency becomes frequency set in parameter 01-08.
- Continuous use of short-circuit braking may damage internal IGBTs.
- Short-circuit braking is controlled by multi-function input option 65.

07-07	DC Injection Braking Level	Default: 50
Range	【0–100】 %	
07-08	DC Injection Braking Time	Default: 0.5
Range	【0.00–100.00】 Sec	

DC Injection Braking Operation (V/f + SLV Mode)

When DC Injection braking is active, DC voltage is applied to the motor, increasing the braking current and resulting in an increase in the strength of the magnetic field trying to hold the motor shaft.

To enable DC injection braking during a start operation, set the DC injection braking current (07-07) to a value greater than 0. DC injection braking at start can be used to prevent “wind milling effect” in fan applications.

To enable DC injection braking during a stop operation, set the DC injection braking current (07-07) and the DC injection braking time at stop (07-08) to a value greater than 0.

Notes:

- Increasing the DC braking time (07-08, 07-16) can reduce the motor stop time.
- Increasing the DC braking current (07-07) can reduce the motor stop time.

DC braking operation can be controlled by any of the multi-function input terminals (03-00 to 05) set to function 33.

See parameters 07-11 and 07-15 for more DC Injection options.

07-09	Stop Mode Selection	Default: 0
Range	【0】 : Deceleration to stop 【1】 : Coast to stop 【2】 : DC braking to stop 【3】 : Coast to stop with timer	

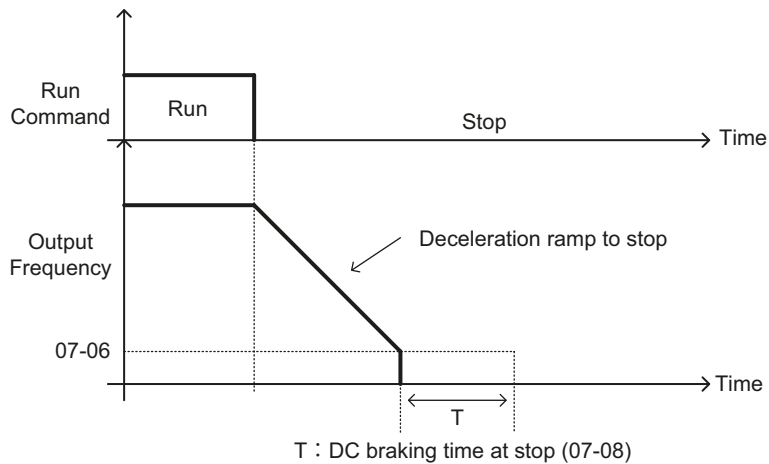
When a stop command is issued the AC Drive stops according to the stop method selected. There are four types of stop modes:

07-09 =0: Deceleration to stop

When a stop command is issued, the motor will decelerate to the minimum output frequency (01-08) F_{min} and then stop. Deceleration rate depends on the deceleration time (factory default: 00-15).

When the output frequency reaches the DC braking stop frequency (07-06) or the minimum output frequency (01-08), DC injection braking is activated and the motor stops.

$$\text{Deceleration time} = \frac{\text{Output frequency when stop command is issued}}{\text{Maximum output frequency } F_{max} \text{ (01-02)}} \times \text{deceleration time setting}$$

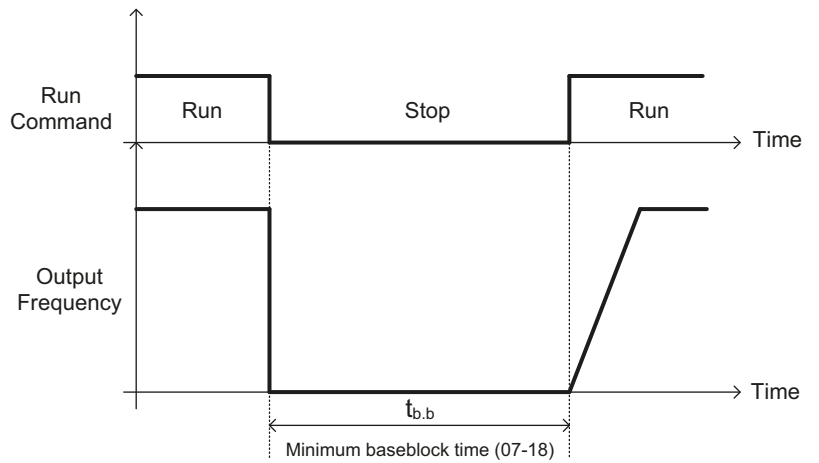


07-09 =1: Coast to stop

When a stop command is issued, the motor will coast to a stop. Stop time depends on motor load and friction of the system.

Notes:

- The AC Drive waits for the time set in the minimum baseblock time (07-18) before accepting the next run command.
- In SLV mode (00-00=2) the speed search function is automatically enabled upon the next run command.



07-09 =2: DC braking to stop

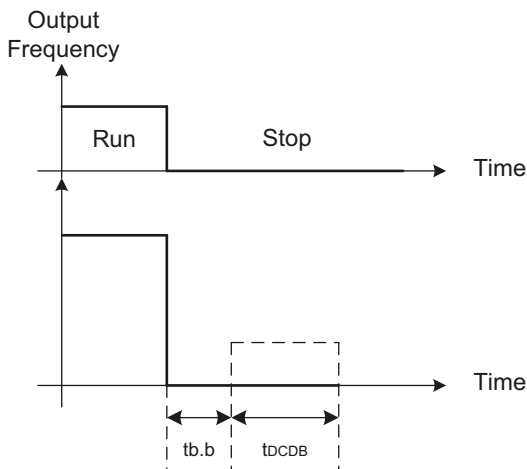
When a stop command is issued, the AC Drive will turn off the output (Baseblock) and activate DC braking (07-07) after the minimum Baseblock time (07-18) has expired.

The DC braking time (tDCDB) of the figure below is determined by the value of 07-08 (DC Braking start time) and the output frequency at the time the stop command was issued.

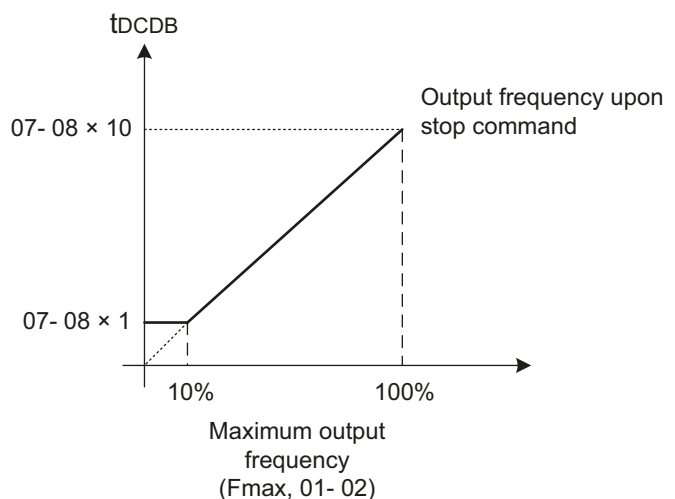
$$\text{DC Inj. Braking time} = \frac{(07-08) \times 10 \times \text{Output frequency}}{\text{Maximum output frequency } F_{\max} (01-02)} \times \text{deceleration time setting}$$

Note:

Increase the minimum Baseblock time (07-18) in case an Overcurrent trip occurs during the DC braking.



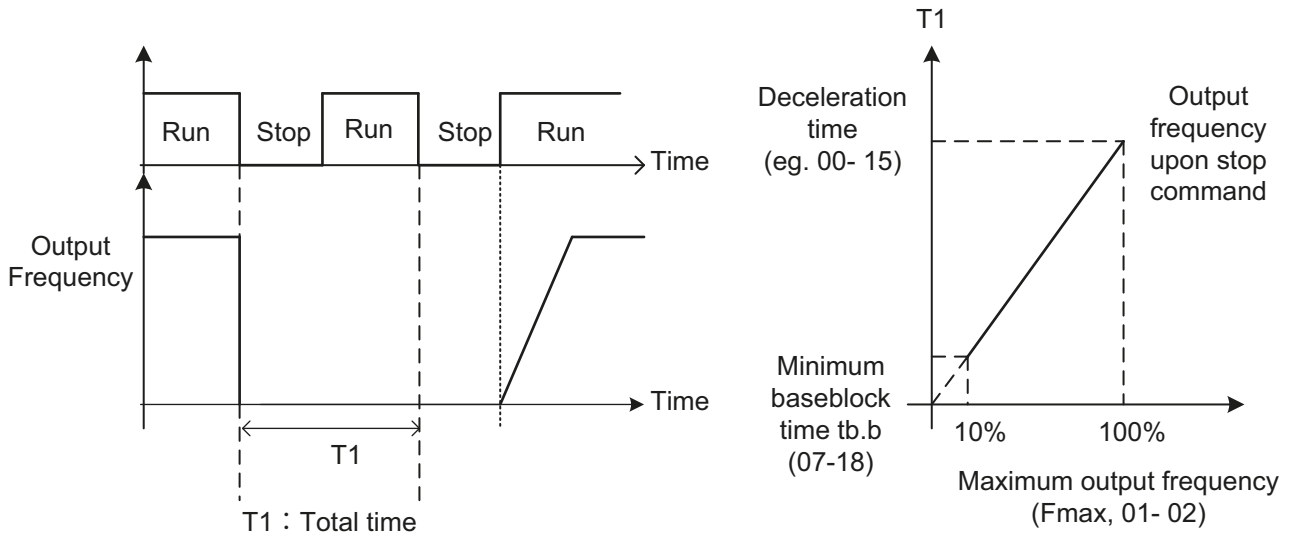
tb.b : Minimum baseblock time (07-18)
tDCDB : DC braking time



07-09 =3: Coast to stop with timer

When a stop command is issued the motor will coast to a stop after the minimum Baseblock time (07-18) has expired and the AC Drive ignores the run command until the timer has expired.

The total time of the timer is determined by the deceleration time (00-15, 17, 22 or 24) and the output frequency upon stop. Refer to figure below for details.



07-10	Speed Search mode Selection	Default: 0
Range	【0】 : Disabled 【1】 : Execute speed search once 【2】 : Speed Search Start	

07-10 = 0: Speed search is disabled and the AC Drive output frequency starts from min. frequency (01-08).

07-10 = 1: Speed search is enabled and activated only once after power-up and first run command.

07-10 = 2: Speed search is enabled and activated after every run command

Note:

Speed search function is unavailable for AC Drive size 1 and 2 and control mode set to PMSLV (00-00=5).

07-11	DC Braking Time at Start	Default: 0.00
Range	【0.00–100.00】 Sec	

07-13	Low voltage detection level	Default: 190 or 380
Range	【240V Class: 150–300V】 【480V Class: 250–600V】	

Parameter 07-13 low voltage detection level can be adjusted from 150 to 300 VDC (240V class) or 250 to 600 VDC (480V class).

When the AC input voltage is lower than the value set in 07-13 divided by 1.414 (AC voltage detection level) for the time specified in 07-25, a low-voltage error "UV" will be displayed. If 07-25 = 0.00 sec., the UV error will be displayed immediately.

Important Notes:

1. The AC Drive input voltage can limit the output voltage. The connected motor may stall if the input voltage drops excessively or if the load is too big.
2. If the input voltage drops below the value set in 07-13, then the AC Drive output is turned off momentarily. The AC Drive will not automatically start when power is restored.

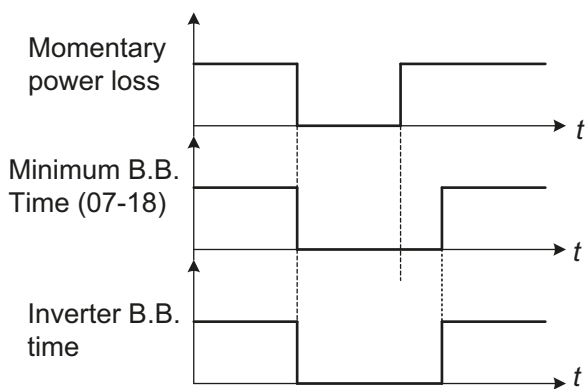
07-15	DC Injection Brake Mode	Default: 1
Range	【0】 : Voltage Mode 【1】 : Current Mode	

07-18	Minimum base block time	Default: 0.5
Range	【0.1–5.0】 Sec	

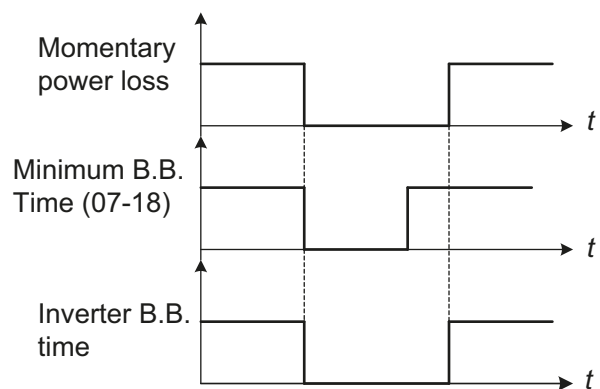
During a momentary power failure, the AC Drive continues to operate after power has been restored when parameter 07-00 is set to 1.

When a momentary power failure is detected, the AC Drive will automatically shut off the output and stay in base block mode (B.B.) for the time set in (07-18).

The AC Drive will automatically perform a speed search when power is restored and power outage time exceeded the minimum base block time (07-18); refer to the following figure below for additional information.



(a) Minimum baseblock time (07-18) greater than momentary power loss time



(b) Minimum baseblock time (07-18) is shorter than momentary power loss time

Notes:

- Minimum base block time (07-18) is also used by the DC injection braking function
- Set the minimum base block time as required (07-18).
- Increase minimum Baseblock time if over-current "OC" condition occurs.
- After speed search has ended the AC Drive returns to normal operation.

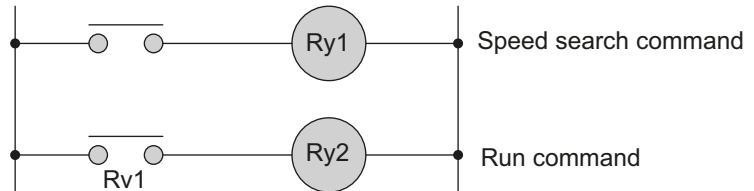
07-19	Speed Direction Search Operation Current	Default: 50
Range	【0–100】 %	
07-20	Speed Search Operating Current	Default: 20
Range	【0–100】 %	
07-21	Integral time of speed searching	Default: 2
Range	【0.1–10.0】 Sec	
07-22	Delay time of speed searching	Default: 0.2
Range	【0.0–20.0】 Sec	
07-23	Voltage recovery time	Default: 2
Range	【0.1–5.0】 Sec	
07-24	Direction-Detection Speed Search Selection	Default: 1
Range	【0】 : Disable 【1】 : Enable	

Speed search function is used to find the speed of a coasting motor and continue operation from that point. The speed search function is active after a momentary power loss.

Speed Search from Multi-function digital inputs

Set the multi-function digital input to external speed search command 1 or 2. External speed search command 1 (value = 19) and 2 (value = 34) cannot be set at the same time, otherwise "SE02" (digital input terminal error) warning occurs.

Speed search function must be enabled before applying the run command to ensure proper operation. See relay logic in figure at right.



Notes: Speed Search Operation

- The speed search cannot be used when the motor rated power is greater than the AC Drive rated power.
- The speed search cannot be used when the motor rated power is two AC Drive sizes smaller than the AC Drive currently used.
- Speed search cannot be used in combination with a high-speed motor.
- In V/F mode, it is necessary to perform a static auto-tune.
- In SLV mode, it is necessary to perform a rotational auto-tune. Perform a static auto-tune when using long motor leads.

07-19: Speed Direction Search Operating Current

- Used in bidirectional speed search only (07-24 = 1).
- Set bidirectional current level.
- Increase value if speed search is not successful at low speeds (above 5Hz)

Note: May cause DC braking effect if the value is too high.

07-20: Speed Search Operating Current

- Can be used for bidirectional (07-24 = 1) or unidirectional (07-24 = 0) speed search.
- Sets speed search current Level.
- The set value must be lower than the excitation current (02-09) and must be equal to the no-load current. If the no-load current is unknown it is recommended to set value at 20%.
- Excessive speed search current will cause AC Drive output to saturate.
- It is recommended to use speed search in case of a momentary power loss. Increase the minimum base block time (07-18) in case of an over-current condition.

07-21: Integral time of speed searching

- Can be used for bidirectional (07-24 = 1) or unidirectional (07-24 = 0) speed search.
- Set the integral time during speed search.
- If an OV fault occurs, increase the set value to increase the speed search time. Decrease the value if a quick start is required

07-22: Delay time of speed searching

- Use delay time when using a contactor on the AC Drive output side.
- The AC Drive speed search starts after the delay time expires.
- Speed search delay time is disabled when set to 0.0 sec. (07-22 = 0.0)

07-23: Voltage recovery time

- Sets the voltage recovery time.
- Sets time for the AC Drive to restore output voltage from 0V to specified V/f level after speed search is complete.

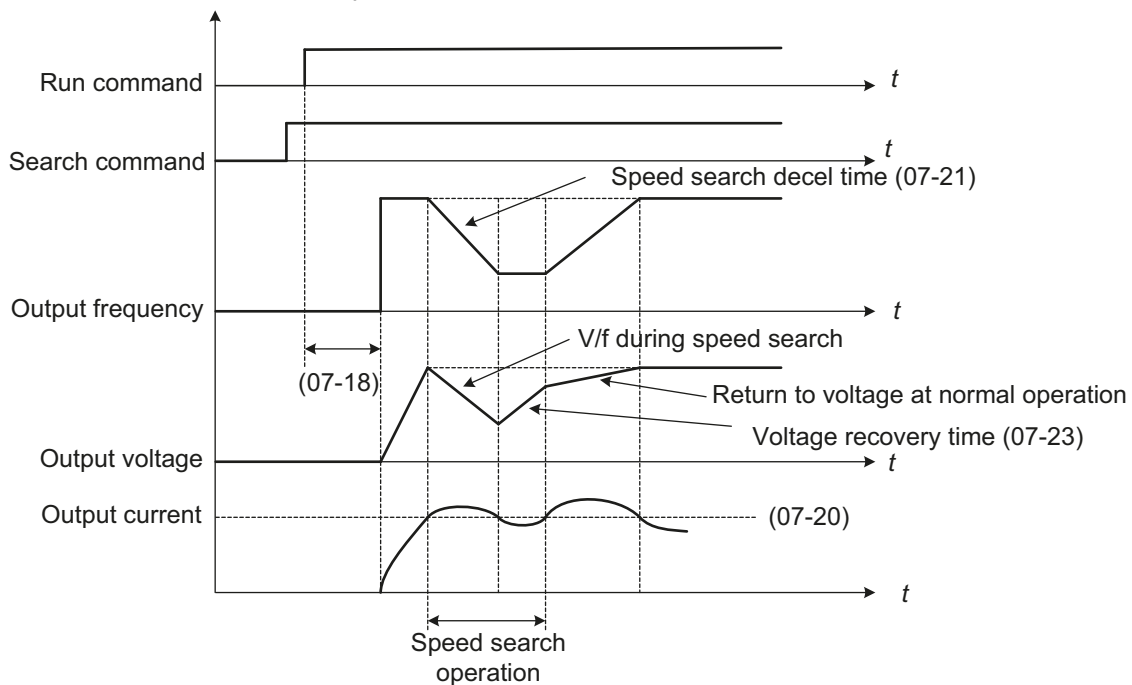
07-24: Direction-Detection Speed Search Selection

0: Disable Direction-Detection Speed Search

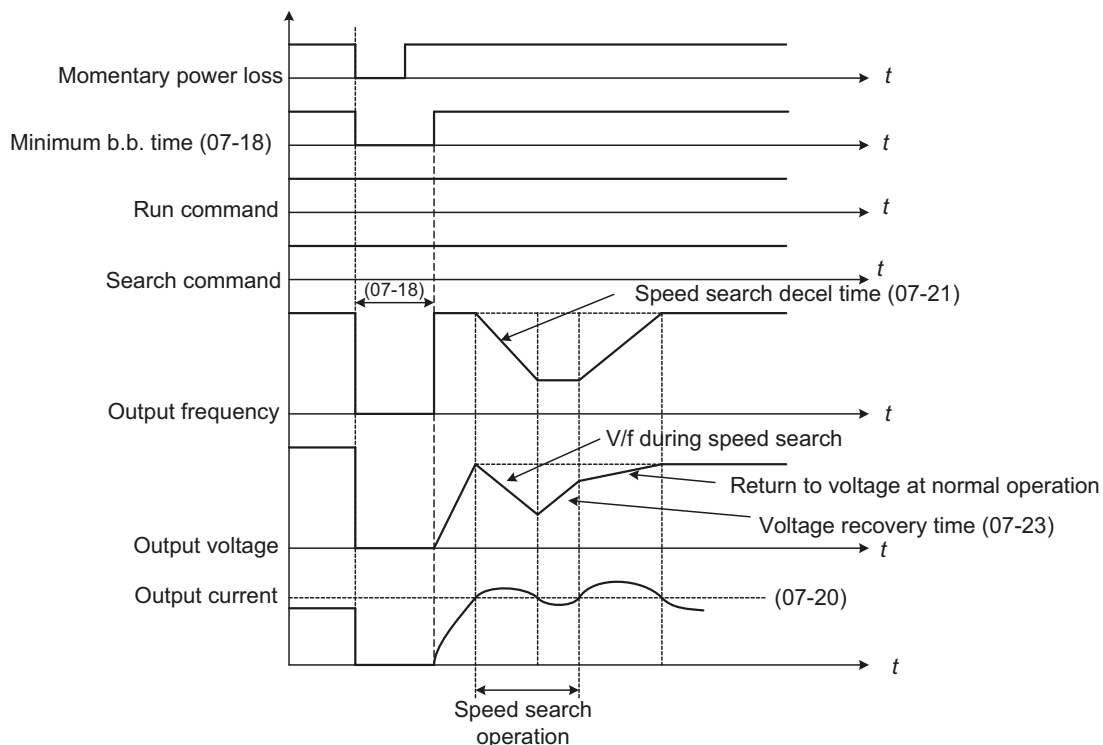
Speed search is executed using speed search operating current defined in parameter 07-20. In case speed search is not successful (e.g. motor speed is too low) a speed search time-out warning is displayed. Set 07-19 to value greater than 0 to enable DC braking at speed search if a time-out occurs frequently.

1: Enable Direction-Detection Speed Search

At start the current controller will send a step current to the motor (07-19) to determine the motor direction. Once direction is determined the current controller will perform a speed search using speed search operating current defined in parameter 07-20. Speed search is executed after a momentary power loss (external speed search command 2, 03-00 to 03-05 = 34) or from max. frequency (external speed search command 1, 03-00 to 03-05 = 19). Speed search direction will follow the speed command.



(b) Speed search in recovery period of momentary power failure



Notes:

If the minimum base block time (07-18) is longer than the momentary power failure time, the speed search starts operation after the minimum base block time (07-18).

If the minimum base block time (07-18) is too short, the speed search operation begins immediately after power has been restored.

07-25	Low voltage detection time	Default: 0.02
Range	【0.00–1.00】 Sec	

Note: See parameter 07-13 for details on Low Voltage Detection.

07-26	Start-up Mode of SLV Coast to Stop	Default: 0
Range	【0】 : Start with speed search 【1】 : Normal start	
07-27	Start after Fault During SLV Mode	Default: 0
Range	【0】 : Start with speed search 【1】 : Normal start	
07-28	Start after External Base-Block	Default: 0
Range	【0】 : Start with speed search 【1】 : Normal start	
07-29	Run Command at the Action of DC Braking	Default: 0
Range	【0】 : Not Allowed to Run 【1】 : Allowed to Run	
07-33	Start Frequency of Speed Search Selection	Default: 0
Range	【0】 : Maximum Output Frequency of Motor 【1】 : Frequency Command	

07-33: Start Frequency of Speed Search Selection

0: The speed search starts from the maximum output frequency of motor.

1: The speed search starts from frequency command.

07-34	Start short-circuit braking time	Default: 0
Range	【0.00–100.00】 Sec	
07-35	Stop Short-circuit braking time	Default: 0.5
Range	【0.00–100.00】 Sec	
07-36	Short-circuit braking current limited	Default: 100
Range	【0.0–200.0】 %	
07-37	Pre-excitation time	Default: 2
Range	【0.00–10.00】 Sec	
07-38	Pre-excitation initial level	Default: 100
Range	【50–200】 %	

If a high starting torque is required for the application, especially for large horsepower motors, the pre-excitation operation can be used to pre-flux (magnetize) the motor.

07-37 Pre-excitation time

When an operation command (forward or reverse) is activated, the AC Drive will automatically start pre-excitation based on the time set in parameter 07-37.

Notes:

1. The time for the flux to reach 100% is a function of the motor's electrical time constant, see figure below.
2. Electrical time constant can be calculated by using the motor parameter settings (group 02).

$$\text{Electrical time constant } T_2 = \frac{\text{Motor leakage inductance (02-17)} + \text{motor mutual inductance (02-18)}}{\text{Motor leakage resistance}}$$

Set the pre-excitation time (07-37) based on the electrical time constant T_2

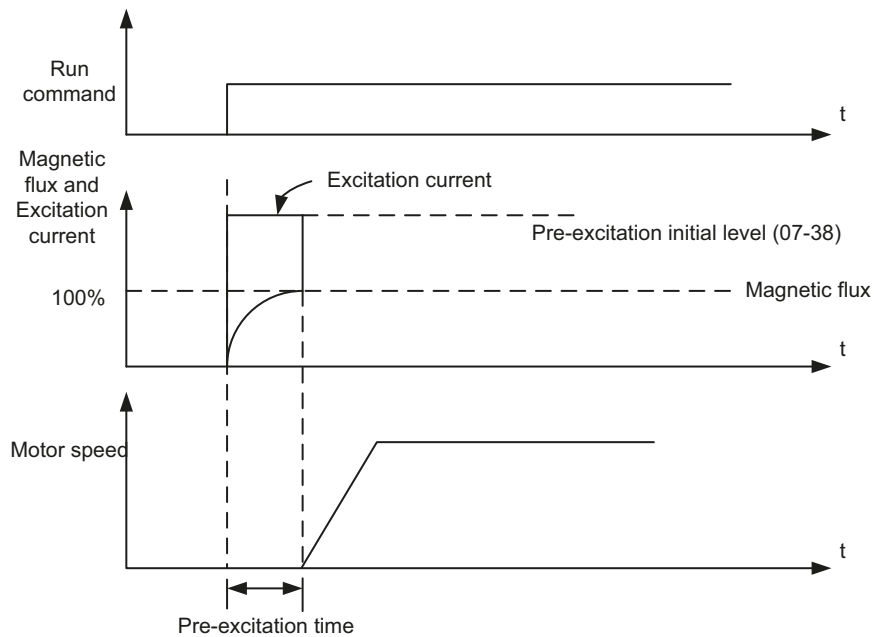
07-38 Pre-excitation initial level

Use the pre-excitation initial level (07-38) to provide a higher excitation current during pre-excitation time (07-37); this will increase the speed and stability for motors.

To quickly magnetize the motor, reduce the pre-excitation time (07-37) and set the pre-excitation level (07-38) to a high level. When the setting reaches 200%, magnetization is reduced by roughly half.

A high pre-excitation level (07-15) might result in excessive motor sound during pre-excitation.

When the flux reaches 100%, pre-excitation current reverts back to 100% and pre-excitation is completed; refer to figure on the right for more information.



07-39	Short-Circuit Braking Time of PM Motor Speed Search Function	Default: 100
Range	【0.00–100.00】 Sec	
07-40	Short-circuit Braking Time of PM Motor Speed Search Function	Default: 100
Range	【0.00–100.00】 Sec	
07-45	Terminal Stop Display	Default: 0
Range	【0】 : Enable 【1】 : Disable	

07-45: Terminal Stop Display

When Enabled, keypad will display “Terminal STOP” when 00-02=1 and external operation signal is tripped or when stop command is issued from keypad.

08 Protection Parameters

08-00	Stall prevention function	Default: 0000b
Range	【xxx0b】 : Stall prevention function is enabled during acceleration. 【xxx1b】 : Stall prevention function is disabled during acceleration. 【xx0xb】 : Stall prevention function is enabled during deceleration. 【xx1xb】 : Stall prevention function is disabled during deceleration. 【x0xxb】 : Stall prevention function is enabled during operation. 【x1xxb】 : Stall prevention function is disabled during run. 【0xxxb】 : Stall prevention function during run is based on the first acceleration time. 【1xxxb】 : Stall prevention function during run is based on the second acceleration time.	
08-01	Stall prevention level during acceleration	Default: HD:150, ND:120
Range	【20–200】 %	
08-02	Stall prevention level during deceleration	Default: 385 or 770
Range	240V : 【330V–410V】 480V : 【660V–820V】	
08-03	Stall prevention level during run	Default: HD:160, ND:120
Range	【30–200】 %	

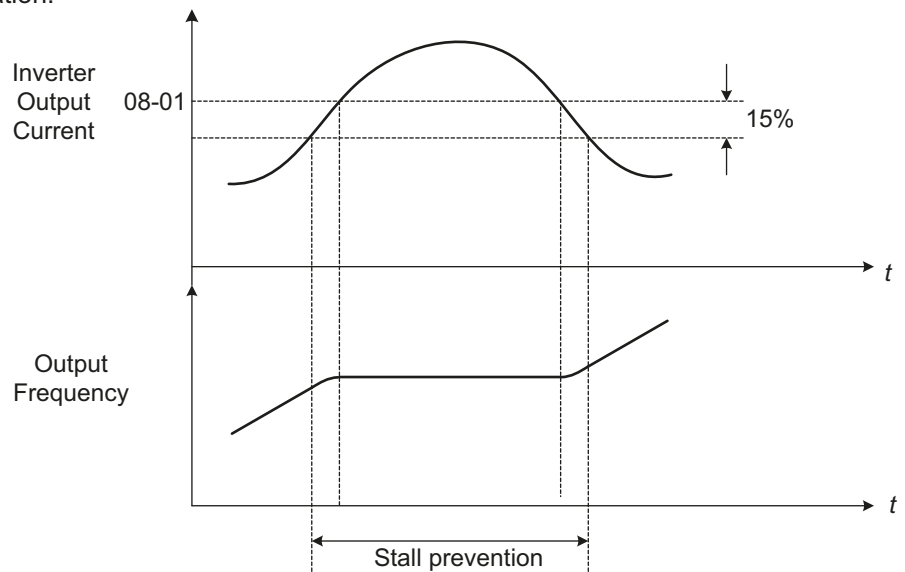
Stall prevention during acceleration (08-00=xxx0b)

Prevents the AC Drive from faulting (Overcurrent, Motor overload, AC Drive overload) when accelerating with heavy loads.

When the AC Drive output current reaches the level set in parameter 08-01 minus 15% the acceleration rate starts to decrease. When the AC Drive output current reaches the level set in parameter 08-01 the motor stops accelerating. Refer to figure below for more information.

Notes:

- Reduce stall prevention level during acceleration (08-01) in case the motor stalls (when the motor power is smaller than the AC Drive rating).
- The AC Drive rated output current should be set to 100%.



If the motor is used in the constant power (CH) region, the stall prevention level (08-01) is automatically reduced to prevent the stall.

Stall prevention level during acceleration (Constant horsepower)

$$\text{Stall Prev. Lev. Acceleration (CH)} = \frac{\text{Stall prevention level in acceleration (08-01)} \times \text{Fbase (01-12)}}{\text{Output frequency}}$$

Motor2 Acceleration Stall Prevention Level (08-40) and Motor2 Acceleration Stall Prevention Limit (08-41) are used when 03-00 to 03-07=40 (Switching between Motor 1/Motor 2)

Stall prevention during deceleration (08-00=xx0xb)

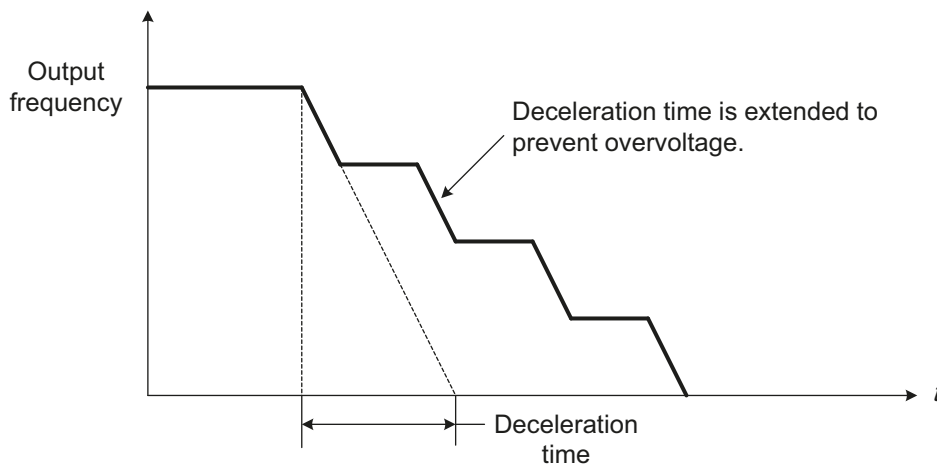
Stall prevention during deceleration automatically increases the deceleration time based on the DC-bus voltage to prevent over-voltage during deceleration. Refer to figure below for stall prevention during deceleration

When the DC-bus voltage exceeds the stall prevention level, deceleration will stop and the AC Drive will wait for the DC-bus voltage to fall below the stall prevention level before continuing deceleration.

Stall prevention level can be set by 08-02, see table below

AC Drive model	08-02 default value
240V class	385VDC
480V class	770VDC

Stall prevention during deceleration function (08-00 to xx1xb) must be set to disabled when using a braking resistor or braking module.



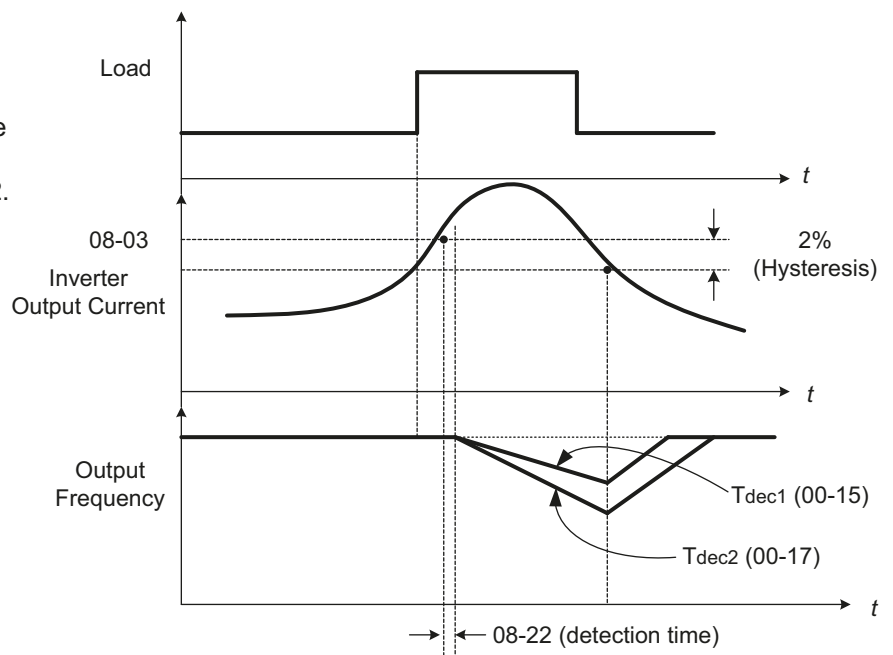
Stall prevention during run (08-00=x0xxb)

Stall prevention during run can only be used in V/F and SLV control mode.

This function prevents the motor from stalling by automatically reducing the output frequency during run.

If the AC Drive output current rises above the level set in parameter 08-03 for the time specified in parameter 08-22, the AC Drive output frequency is automatically decreased following deceleration time 1 (00-15) or deceleration time 2 (00-17).

When the AC Drive output current falls below the level set in parameter (08-03) minus 2%, normal operation continues and the output frequency increases to the frequency reference using the acceleration time 1 or acceleration time 2. Refer to the figure at right.



08-05	Motor overload protection (OL1)	Default: V/F & SLV:0001b, PMSLV:0101b
Range	【xxx0b】 : Motor overload is disabled 【xxx1b】 : Motor overload is enabled 【xx0xb】 : Cold start of motor overload 【xx1xb】 : Hot start of motor overload 【x0xxb】 : Standard motor 【x1xxb】 : Special motor 【0xxxb】 : Reserved 【1xxxb】 : Reserved	

The motor overload protection function estimates the motor overload level based on the output current, output frequency, motor characteristics and time. The motor overload trip time depends on the motor rated current when the output frequency is greater than 60Hz. The electronic thermal overload function is UL-recognized, so an external thermal overload relay is not required for single motor operation.

On AC Drive power-up the motor overload protection internal thermal accumulation register is automatically reset.

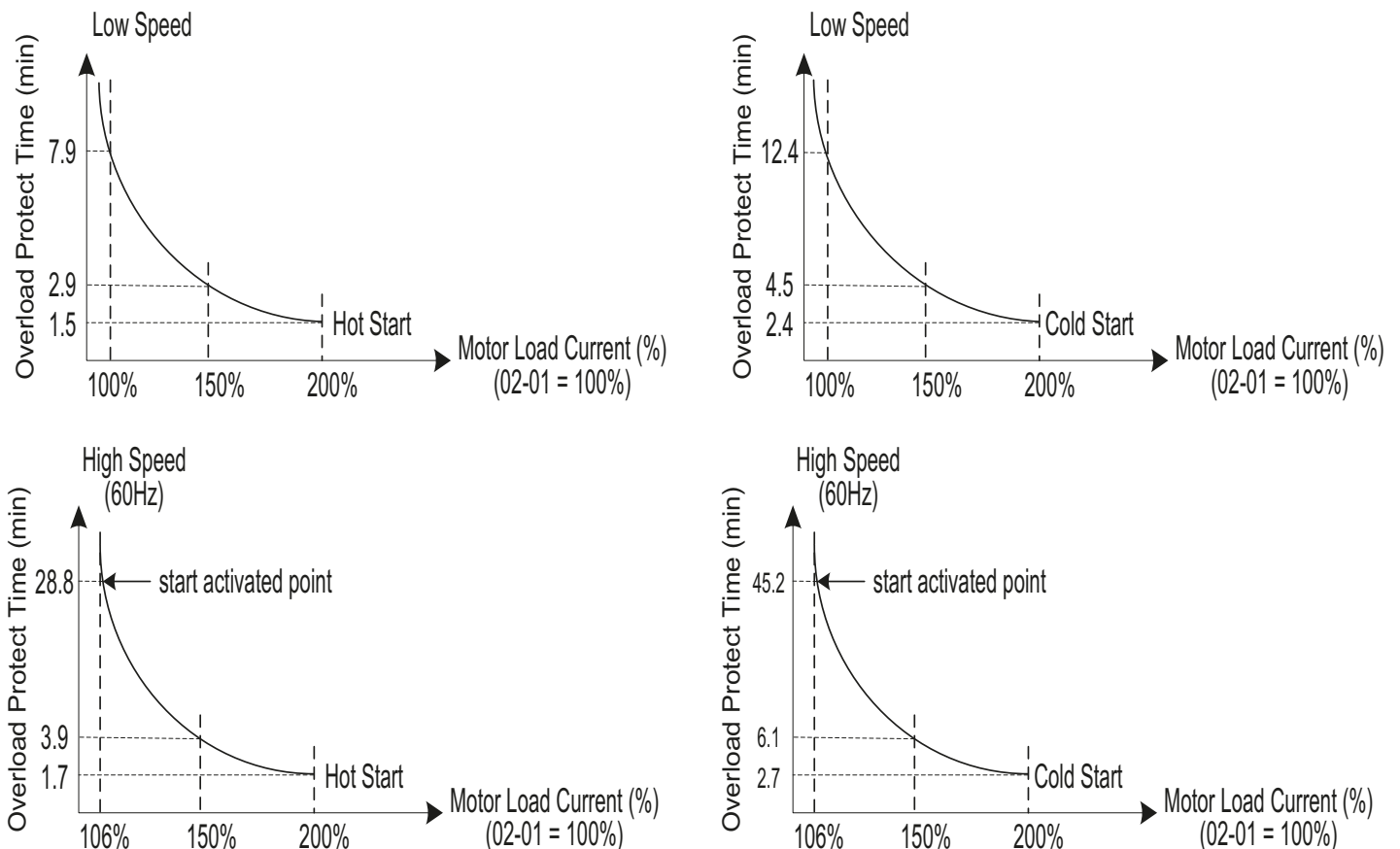
To use the built-in motor overload protection function, parameter 02-01 (motor rated current) has to match the motor rated current on the motor nameplate.

Turn off the motor overload protection when using two or more motors connected to the AC Drive (set **08-05 = xxx0b**), and provide external overload protection for each motor (e.g. thermal overload switch).

With cold start enabled (**08-05 = xx0xb**), motor overload protection occurs in 5.5 minutes when operating the motor at 150% of the motor rated current at an output frequency greater than 60Hz.

With hot start enabled (**08-05 = xx1xb**), motor overload protection occurs in 3.5 minutes when operating the motor at 150% of the motor rated current at an output frequency greater than 60Hz. Use hot start when the power supply is turned on and off frequently because the thermal values are reset each time power is turned off.

Refer to the following figure for an example of motor overload protection curve.

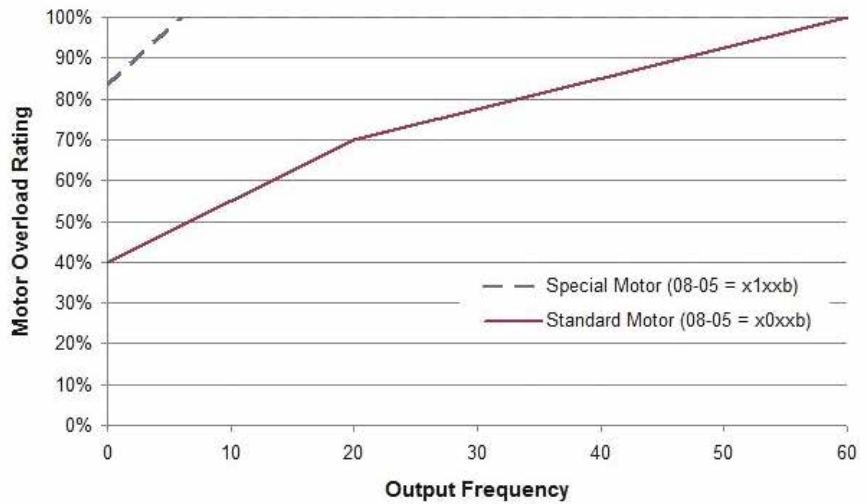


When using force cooled motors (Special AC Drive motor), thermal characteristics are independent of the motor speed, set **08-05 = x1xxb**.

When **08-05 = x1xxb**, overload protection function is based on motor rated current for output frequencies between 6 and 60Hz. If the output frequency is less than 1Hz, the overload protection function uses 83% of the motor rated current to determine an overload condition.

When **08-05 = x0xxb**, overload protection function is based on 70% of the motor rated current for an output frequency of 20Hz. If the output frequency is lower than 1Hz, the overload protection function uses 40% of the motor rated current to determine an overload condition.

Motor overload rating at different output frequencies is shown to the right.



08-06	Start-up mode of overload protection operation (OL1)	Default: 0
Range	【0】 : Stop output after overload protection 【1】 : Continuous operation after overload protection	

08-06=0: When the AC Drive detects a motor overload the AC Drive output is turned off and the OL1 fault message will flash on the keypad. Press RESET button on the keypad or activate the reset function through the multi-function inputs to reset the OL1 fault.

08-06=1: When the AC Drive detects a motor overload the AC Drive will continue running and the OL1 alarm message will flash on the keypad until the motor current falls within the normal operating range.

08-07	Overheat protection (cooling fan control)	Default: 1
Range	【0】 : Auto (Depends on temperature) 【1】 : Operate while in RUN mode 【2】 : Always Run 【3】 : Stop Operation	

Over heat protection (Cooling fan control) (08-07)

08-07=0: Fan turns on when the heat-sink temperature rises above the maximum heat-sink temperature. When the heat-sink temperature falls below the maximum heat-sink temperature for the time specified in 08-38, the fan turns off.

08-07=1: The fan turns on when the AC Drive is in run mode. When the AC Drive has stopped the fan stays running for the time specified in 08-38 before the fan is turned off.

08-07=2: Fan turns on when power is applied to the AC Drive.

Note:

The cooling fan stays running when 08-07=0 and the heatsink temperature is still above the maximum heat-sink temperature

08-08	Automatic voltage regulation (AVR)	Default: 0
Range	【0】 : AVR enabled 【1】 : AVR disabled	

Automatic voltage regulation stabilizes the motor voltage independent of fluctuation to the input voltage.

08-08=0: Automatic voltage regulation is active. It will limit the maximum output voltage. When three-phase input voltage fluctuates and the voltage is smaller than the value of 01-14, the output voltage will fluctuate in sync with the input voltage.

08-08=1: Automatic voltage regulation is not active, motor voltage follows the input voltage fluctuation. When three-phase input voltage fluctuates, the output voltage will not fluctuate in sync with the input voltage.

08-09	Phase loss protection	Default: 0
Range	【0】 : Disable 【1】 : Enable	

08-09=0: Input phase loss detection is disabled.

08-09=1: Input phase loss detection is enabled. Keypad shows "IPL input Phase Loss" (IPL), when an input phase loss is detected the AC Drive output is turned off and the fault contact is activated.

Note:

The input phase loss detection is disabled when the output current is less than 30% of the AC Drive rated current.

08-10	Output phase loss protection	Default: 0
Range	【0】 : Disable 【1】 : Enable	

08-10=0: Output phase loss detection is disabled.

08-10=1: Output phase loss detection is enabled. When an output phase loss is detected the AC Drive output is turned off , AC Drive fault contact is activated and the keypad shows "OPL Output Phase Loss" (OPL),

Note:

The output phase loss detection is disabled when the output current is less than 10% of the AC Drive rated current.

Over-torque Detection

The over torque detection function monitors the AC Drive output current or motor torque and can be used to detect an increase in AC Drive current or motor torque (e.g. heavy load).

The torque detection level (08-15) is based on the AC Drive rated output current (100% = AC Drive rated output current) when operating the AC Drive in V/F control and motor output torque (100% = motor rated torque) when operating the AC Drive in SLV control.

08-13	Over-torque detection	Default: 0
Range	【0】 : Over-torque detection is disabled 【1】 : Start detection when reaching the set frequency 【2】 : Start detection during run mode	
08-14	Over-torque action	Default: 0
Range	【0】 : Deceleration to stop when over-torque is detected. 【1】 : Displays warning when over-torque is detected. Continue operation. 【2】 : Coast to stop when over-torque is detected	
08-15	Level of over-torque detection	Default: 160
Range	【0-300】 %	
08-16	Time of over-torque detection	Default: 0.1
Range	【0.0-10.0】 Sec	

Parameter 08-13 selects over-torque detection function. An over-torque condition is detected when the output current / torque rises above the level set in parameter 08-15 (Over-torque detection level) for the time specified in parameter 08-16 (Over-torque detection time).

08-13=0: Over-torque detection is disabled.

08-13=1: Over-torque detection is enabled when the output frequency reaches the set frequency.

08-13=2: Over-torque detection is enabled during run mode.

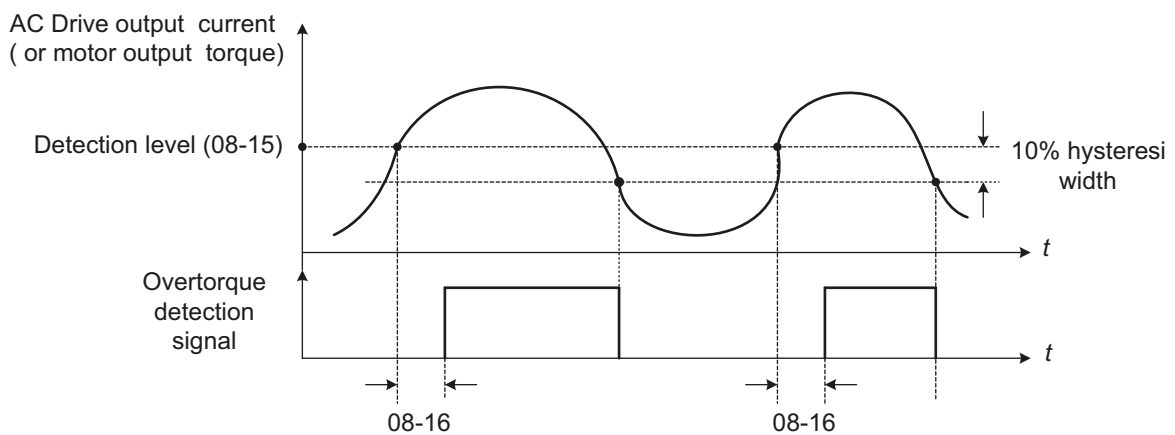
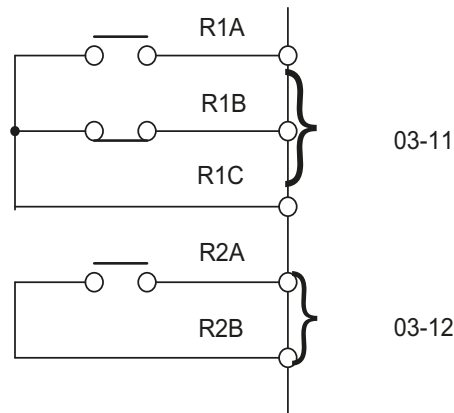
Parameter 08-14 selects the way the AC Drive acts when an over-torque condition is detected.

08-14=0: When an over-torque condition is detected the AC Drive displays an over-torque detection fault and the motor decelerates to a stop.

08-14=1: When an over-torque condition is detected the AC Drive displays an over-torque detection alarm and continues to run.

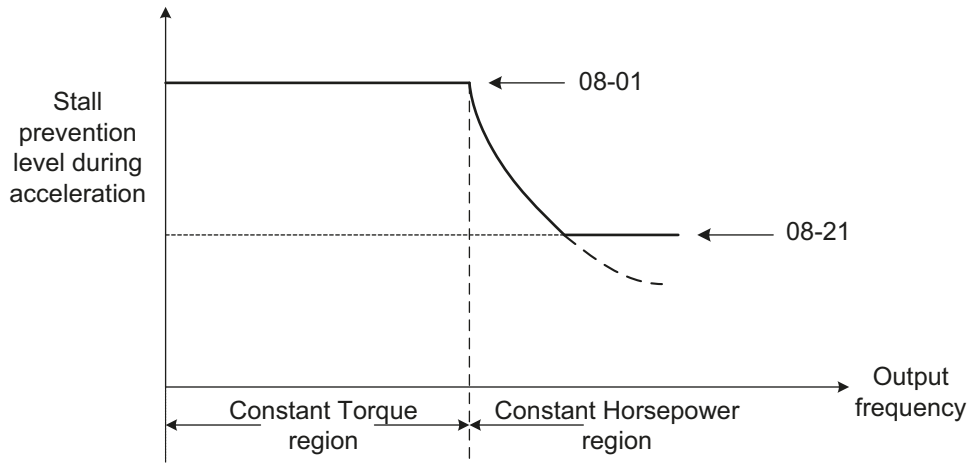
08-14=2: When an over-torque condition is detected the AC Drive displays an over-torque detection fault and the motor coasts to a stop

Multi-function digital outputs (R1A-R1C, R2A-R2C) can be set to an over torque detection condition by setting parameters 03-11 or 03-12 to 12. Refer to the following figure.



08-21	Limit of stall prevention during acceleration	Default: 50
Range	【1-100】 %	
08-22	Stall prevention detection time during run	Default: 100
Range	【2-100】 ms	

Parameter 08-21 is the stall prevention limit value in Constant Horsepower region. Refer to figure below.



08-23	Ground Fault (GF) Selection	Default: 0
Range	【0】 : Disabled 【1】 : Enabled	

If the AC Drive leakage current is greater than 60% of AC Drive rated current (adjustable using parameter 08-61) and the ground fault function is enabled (08-23=1), the keypad will display "GF", motor will coast to a stop, and fault contact is activated.

08-24	Operation of External Fault	Default: 0
Range	【0】 : Deceleration to Stop 【1】 : Coast to Stop 【2】 : Continuous Operation	
08-25	Detection of External Fault	Default: 0
Range	【0】 : Immediately Detect When the Power is Supplied 【1】 : Start to Detect during Operation	
08-35	Motor Overheat Fault Selection	Default: 0
Range	【0】 : Disabled 【1】 : Deceleration to Stop 【2】 : Free run to Stop 【3】 : Continue Running	

Motor Overheat Fault Selection

Enable the motor overheat protection by using the PTC resistor built-into the motor. Connect the PTC resistor between AI2 and GND and a resistor R between AI2 and +10V, see figure below.

08-35=0: Motor overheats fault function is off.

08-35=1: When the motor is overheating, decelerate to stop.

08-35=2: When the motor is overheating, coast to stop.

08-35=3: When the motor is overheating, continue running until value set in 08-42 is reached.

08-35=1 or 2: The AC Drive will display [OH4 Motor Temp Warning] when the motor temperature increases and AI2 voltage level rises above the value set in 08-44. In this condition the motor will decelerate or coast to stop depending on setting 08-35=1 or 2.

08-35=3: The AC Drive will display [OH3 Motor Temp Warning] when the motor temperature increases and AI2 voltage level rises above the value set in 08-44. In this condition the motor will continue running. If AI2 voltage level rises above the value set in 08-42 for the time specified in 08-39 the motor coasts to stop.

08-35=1, 2 or 3: When the motor cools down and AI2 voltage level falls below the value in 08-43, [OH3/OH4 Motor Overheat] will reset.

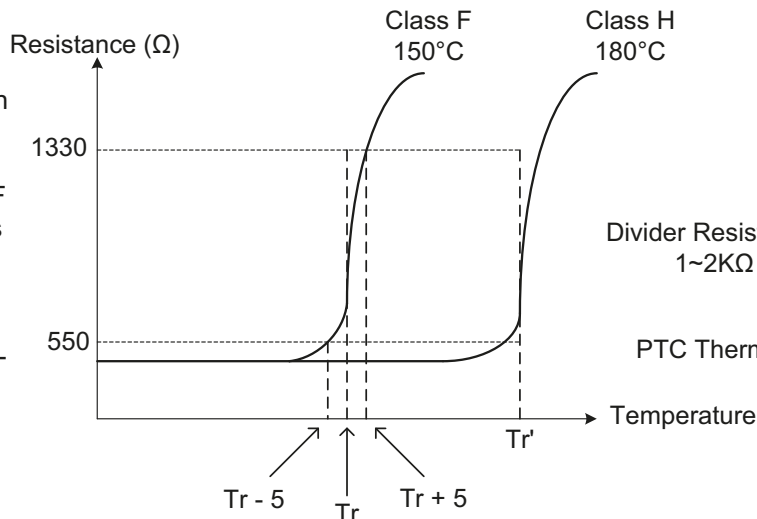
$$V = \frac{1}{2} \times 10 \times \frac{R_{PTC} // 200}{R + (R_{PTC} // 200)} \text{ ----- Formula (1)}$$

Note:
The resistor (PTC) according to the British Standards Institution:

Tr is 150°C for Class F and is 180°C for Class H

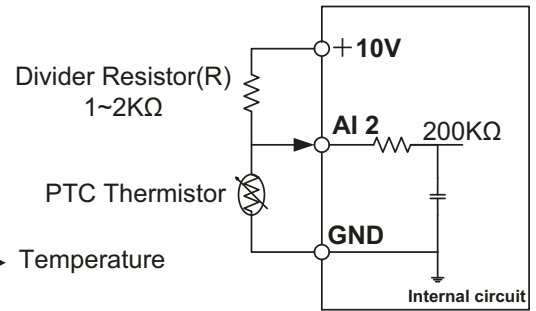
Tr - 5°C : RT ≤ 550Ω, insert value of RT into formula (1) and set 08-43 to the calculated value.

Tr + 5°C : RT ≥ 1330Ω, put the value of RT in formula (1), and set 08-44 to the calculated value.



Tr : Temperature threshold value

(a) PTC Thermistor Characteristics



(b) PTC Thermistor connections

08-36	PTC Input Filter Time Constant	Default: 2
Range	【0.00 – 5.00】	
08-38	Delay Time of Fan Off	Default: 60
Range	【0–600】 Sec	
08-39	Delay Time of Motor Overheat Protection	Default: 60
Range	【1 – 300】 Sec	

08-40	Motor 2 Acceleration Stall Prevention Level	Default: HD:150, ND:120
Range	【20–200】 %	
08-41	Motor 2 Acceleration Stall Prevention Limit	Default: 50
Range	【1–100】 %	

08-42	PTC Protection Level	Default: 0.7
Range	【0.1 – 10.0】 V	
08-43	PTC Restart Level	Default: 0.3
Range	【0.1 – 10.0】 V	
08-44	PTC Warning Level	Default: 0.5
Range	【0.1 – 10.0】 V	
08-46	Temperature Agree Level	Default: 0
Range	【0–254】 °C	
08-47	Temperature Reset Level	Default: 0
Range	【0–254】 °C	

Fire Mode (Run-at-all-Costs Mode)

This function is commonly used in commercial applications where the AC Drive controls an exhaust fan and needs run to destruction in case of a fire.

Warning: Use of this mode for any application must be considered carefully and all safety implications must be taken into account. When enabled and Fire Mode is activated, all protection features of the AC Drive will be disabled and the unit will continue to operate until its possible destruction. All liabilities for the use of this function will remain user's responsibility.

08-48	Fire Mode	Default: 0
Range	【0】 : Disabled 【1】 : Enabled	

08-05 =48: Fire mode

When fire mode is enabled 08-48, digital input S6 (03-05) will be locked to function 47. When S6 input is active, drive will run according to settings in parameters 08-51 through 08-59.

Note: All faults must be cleared before Fire Mode can be disabled

08-49	Fire Mode Multi-function Input Terminal Status	Default: 0
Range	【0】 : Reset after Power Off 【1】 : Reset after Terminal Removed	
08-50	Fire Mode Multi-function Terminal Status	Default: 0000b
Range	【xxx0b】 : S6 A Contact 【xxx1b】 : S6 B Contact	
08-51	Fire Mode Motor Speed Source	Default: 0
Range	【0】 : Fire Mode Speed (08-52) 【1】 : PID Control 【2】 : AI2	
08-52	Fire Mode Motor Speed	Default: 100
Range	【0.00–100.00】 %	

Note: Parameters 08-53 to 08-55 are only accessible after selecting PID Control by setting 08-51=1.

08-53	Fire Mode PID Feedback Loss Detection Level	Default: 0
Range	【0–100】	
08-54	Fire Mode PID Feedback Loss Detection Time	Default: 1.0
Range	【0.0–10.0】	
08-55	Fire Mode PID Feedback Loss Detection Action	Default: 1
Range	【0】 : Keep Running 【1】 : Fire Mode Speed (08-52) 【2】 : Max. Output Frequency of Motor 1 (01-02)	

Note: Parameters 08-56 to 08-58 are only accessible after selecting AI2 by setting 08-51=2.

08-56	Fire Mode AI2 Signal Loss Detection Level	Default: 80
Range	【0–100】 %	
08-57	Fire Mode AI2 Signal Loss Detection Time	Default: 1.0
Range	【0.0–10.0】 s	
08-58	Fire Mode AI2 Signal Loss Detection Action	Default: 1
Range	【0】 : Keep Running 【1】 : Fire Mode Speed (08-52) 【2】 : Max. Output Frequency (01-02)	
08-59	Fire Mode Motor Direction	Default: 0
Range	【0】 : Forward 【1】 : Reverse	

08-60	Fire Mode Password	Default: 00000
Range	【00000–65534】	

08-60: Fire Mode Password.

When fire mode password is enabled (08-60>0), fire mode parameters 08-48 to 08-59 cannot be modified. Parameter 08-60 is programmed similar to parameter 13-07.

09 Communication Parameters

09-00	Communication Station Address	Default: 1
Range	【1–32】	
09-01	Communication Mode Selection	Default: 0
Range	【0】 : MODBUS 【2】 : BACnet	
09-02	Baud Rate Setting (bps)	Default: 2
Range	【0】 : 4800 【1】 : 9600 【2】 : 19200 【3】 : 38400	
09-03	Stop Bit Selection	Default: 0
Range	【0】 : 1 stop bit 【1】 : 2 stop bits	
09-04	Parity Selection	Default: 0
Range	【0】 : No Parity 【1】 : Even Bit 【2】 : Odd Bit	
09-05	Communication Data Bit Selection	Default: 0
Range	【0】 : 8 Bit Data 【1】 : 7 Bit Data	
09-06	Communication Error Detection Time	Default: 0
Range	【0.0–25.5】 Sec	
09-07	Fault Stop Selection	Default: 3
Range	【0】 : Deceleration to stop based on deceleration time 1 【1】 : Coast to stop when communication fault occurs 【2】 : Deceleration to stop based on deceleration time 2 【3】 : Continue Operation	
09-08	Communication Error Threshold	Default: 1
Range	【1–20】	
09-09	Waiting Time	Default: 5
Range	【5–65】 ms	
09-10	BACNET Device Instance Number	Default: 1
Range	1–254	

09-06: Communication Error Detection Time

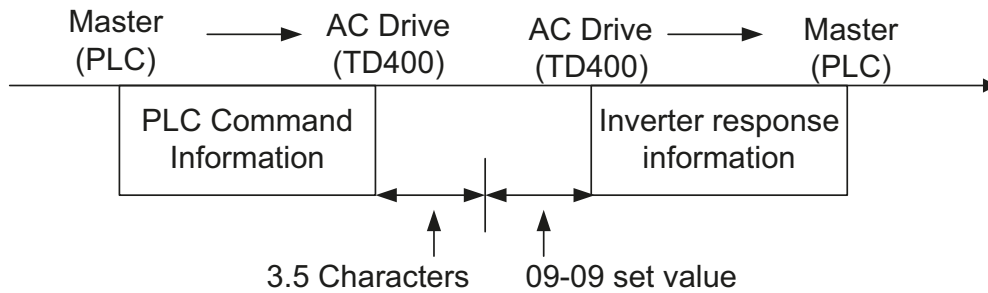
Select the amount of time the drive will wait before a transmission non-response error will be activated. Increasing this time may be necessary if there is excessive noise causing slower transmission times.

09-08: Communication Error Threshold

Select the number of communication error occurrences the drive must encounter before tripping and displaying communication error fault message “CE”.

09-09: AC Drive Transmission Wait Time.

This is the time between the controller message and the start of the AC Drive response message. Refer to Figure below. Set the controller receive time-out to a greater value than the wait time parameter.



Notes: Changes to Group 09 require power cycling the AC drive to take effect. Refer to Chapter 6 for additional communication details.

10 PID Parameters

PID Essentials

PID control is used to maintain a constant target variable such as pressure, flow, or temperature by regulating the output frequency. A feedback device signal is used to compare the actual process variable to a specified target value. The difference between the target value and the feedback signal is called the error signal.

For PID Setup, see the following essential parameters:

- 10-00: PID Target Value Source
- 10-01: PID Feedback Value Source
- 10-02: PID Target Value
- 10-03: PID Control Mode
- 10-33: Maximum Value of PID Feedback
- 10-34: PID Feedback Value Scaling

For PID Tuning, see the following essential parameters:

- 10-05: Proportional Gain
- 10-06: Integral Time
- 10-07: Differential Time
- 00-14: Acceleration Time
- 00-15: Deceleration Time

10-00	PID target value source setting	Default: 1
Range	【0】 : Keypad 【1】 : AI1 (Analog Input 1) 【2】 : AI2 (Analog Input 2) 【3】 : Communication 【4】 : Target Source set by 10-02	

Parameter 10-00 sets where the PID target value will be obtained. PID target is the value that the PID function will attempt to hold. PID target value can either be a constant value or a percentage of the maximum PID feedback (parameter 10-33) depending on the source setting.

10-00=0: Keypad
 PID target value set via keypad

10-00=1 or 2: Analog Input
 PID target value is a percentage of the maximum PID feedback value (parameter 10-33) set proportionally by the analog input signal.

Example: When using 0-10V analog input, 10V = 100% of maximum PID feedback value will be the PID target value; 2V = 20%, etc.

10-00=3: Communication
 PID target value set via serial communication when parameters 00-05=5 and 10-03=xxx1b. Use address 0x2502 (Frequency Command).

10-00=4: Set Value from parameter 10-02

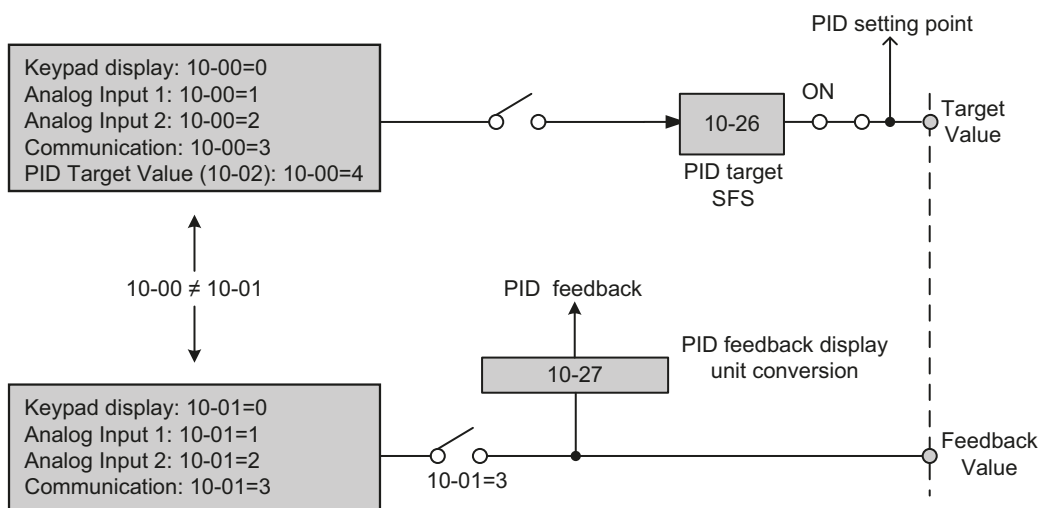
PID target value is defined by constant percentage (parameter 10-02) of the maximum PID feedback value (parameter 10-33).

Note:

10-00 and 10-01 cannot be set to the same value or keypad will show an SE05 alarm.

10-01	PID feedback value source setting	Default: 2
Range	【0】 : Keypad 【1】 : AI1 (Analog Input 1) 【2】 : AI2 (Analog Input 2) 【3】 : Communication	
10-02	PID target value	Default: 0
Range	【0.00–100.00】 %	

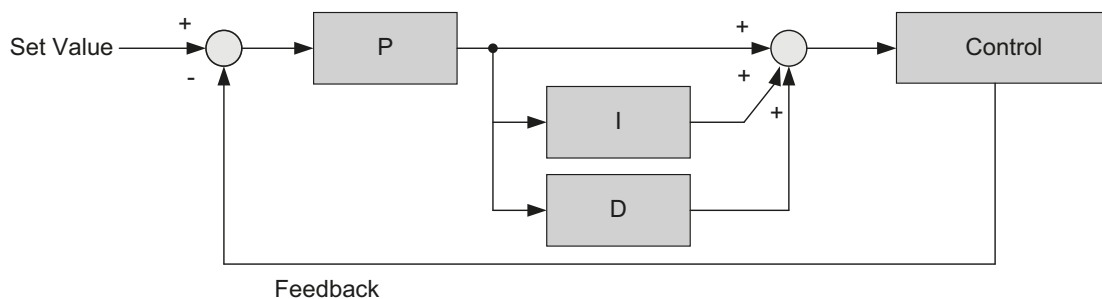
Parameter 10-01 sets the PID feedback value source. This value is what the PID function will use to determine needed output.



10-03	PID control mode	Default: 0000b
Range	【xxx0b】 : PID disable 【xxx1b】 : PID enable 【xx0xb】 : PID positive characteristic 【xx1xb】 : PID negative characteristic 【x0xxb】 : PID error value of D control 【x1xxb】 : PID feedback value of D control 【0xxxb】 : PID output 【1xxxb】 : PID output + Frequency Command	

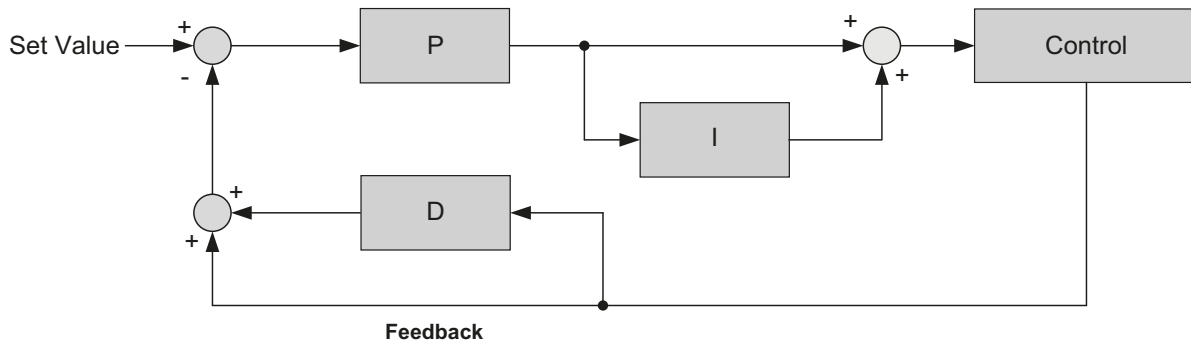
(a) Basic PID control: (10-03 = 0001b, 0011b)

This is the basic type of PID control. Refer to the figure below.



Error signal (target minus feedback) is derivative controlled and set by parameter 10-07.

(b) PID control with differential feedback: (10-03 = 0010b, 0100b)



Feedback (detected value) is derivative controlled and set by parameter 10-07.

Make sure to adjust the PID parameters without causing system instability. Refer to Figure above for PID control for feedback value differential.

For 10-03 = 0001b or 0010b, if error signal (target minus feedback) is positive, output frequency increases and vice versa. For 10-03 = 0011b or 0100b, if error signal (target minus feedback) is positive, output frequency decreases and vice versa.

10-04	Feedback gain	Default: 1
Range	【0.01–10.00】	

10-01 X 10-04 = Feedback Value

PID Tuning

The PID control serves to maintain a given process within certain limits whether it is pressure, flow, etc. To do this the **feedback** signal is compared to the **set value** and the difference becomes the error signal for the PID control.

The PID control then responds by trying to minimize this error. The error is multiplied times the value of the **Proportional gain** set by parameter **10-05**. An increased gain value results in a larger error. However, in any system as the gain is increased there is a point that the system will become unstable (oscillate).

To correct this instability, the response time of the system may be **slowed** down by increasing the **Integral time** set by parameter **10-06**. However, slowing the system down too much may be unsatisfactory for the process.

The end result is that these two parameters in conjunction with the acceleration time (00-14) and deceleration (00-15) times require to be adjusted to achieve optimum performance for a particular application.

PID output polarity can be selected with parameter 10-03 (setting = 1: PID output forward, setting = 3: PID output reversal). When PID output is set to “reverse”, and if PID input is negative, the output frequency of PID will increase. When PID output is set to “forward”, and if PID input is still negative, the output frequency of PID will decrease.

PID feedback value can be adjusted using parameter 10-04 (PID feedback gain) or with the analog input gain and bias for terminal AI1 or AI2.

Use the following procedures to enable PID control:

STEP 1: Increase the proportional gain (10-05) to the highest value possible without causing the system to become unstable.

10-05	Proportional gain (P)	Default: 1
Range	【0.00–10.00】	

10-05 Proportional Gain control: The error signal (deviation) between the input command (set value) and the actual control value (feedback). This error signal or deviation is amplified by the proportional gain (P) to control the offset between the set value and the feedback value.

STEP 2: Decrease the integral time (10-06) to the lowest value possible without causing the system to become unstable.

10-06	Integral time (I)	Default: 1
Range	【0.0–100.0】 Sec	

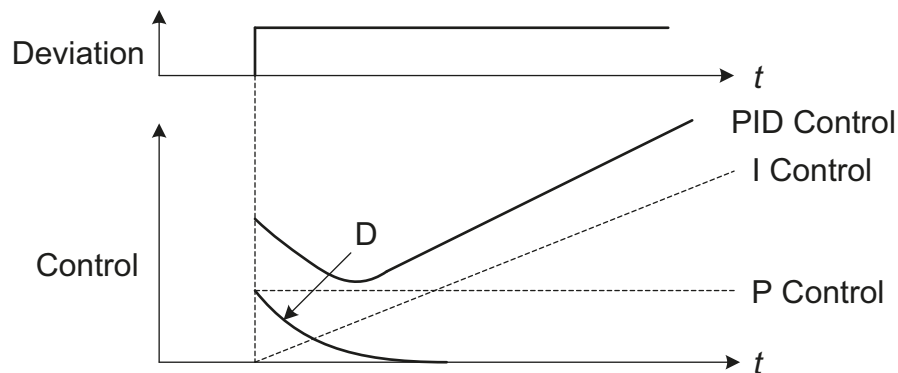
10-06 Integral control: The output of this control is the integral of the error signal (difference between set value and feedback value) and is used to minimize the offset signal that is left over from the gain control. When the integral time (I) is increased, the system response becomes slower.

STEP 3: Increase the differential time (10-07) to the highest value possible without causing the system to become unstable.

10-07	Differential time (D)	Default: 0
Range	【0.00–10.00】 Sec	

10-07 Differential control: This control is the inverse from integral control and tries to guess the behavior of the error signal by multiplying the error with the differential time. The result is added to the PID input. Differential control slows down the PID controller response and may reduce system oscillation. **Note:** Most applications that PID control (fan and pump) do not require differential control.

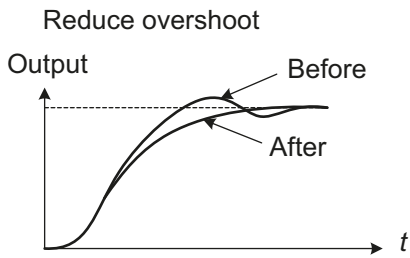
Refer to Figure below for PID control operation



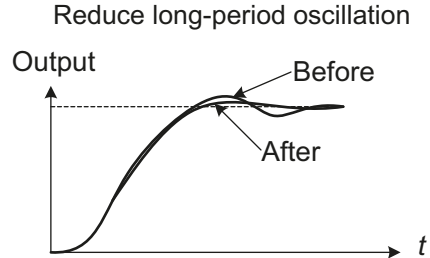
PID Fine Tuning

All PID control parameters are related to each other and require adjustment to the appropriate values. Procedure for achieving the minimum steady-state is as follows:

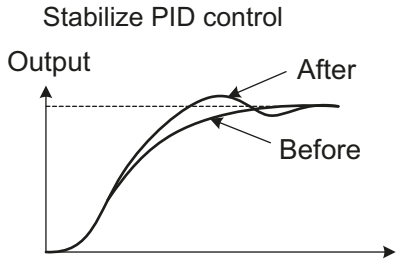
- (1) Increase or decrease the proportional (P) gain until the system is stable using the smallest possible control change.
- (2) Integral (I) reduces the system stability which is similar to increasing the gain. Adjust the integral time so that the highest possible proportional gain value can be used without affecting the system stability. An increase in the integral time reduces system response.
- (3) Adjust the differential time if necessary to reduce overshoot on startup. Acceleration / deceleration time can also be used for the same purpose.



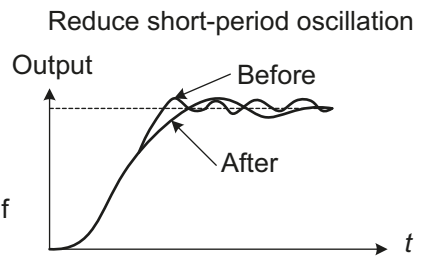
If overshoot occurs, reduce derivative time (D) and increase integral time (I).



Adjust integral time (I) in case of long-period system oscillation.

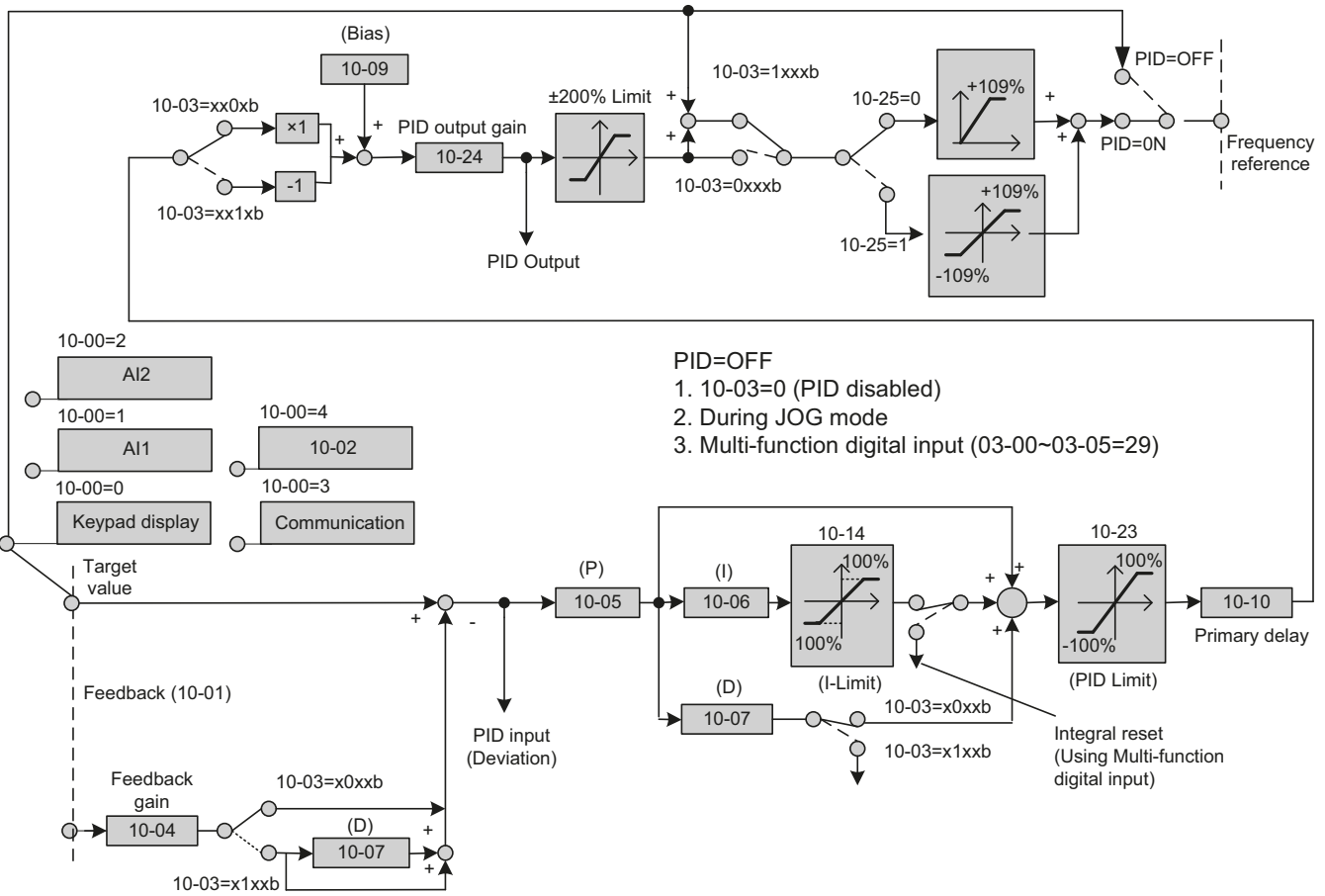


To quickly stabilize the PID control, reduce integral time (I) and increase differential time (D) if overshoot occurs.



Adjust differential time (D) and proportional (P) gain when experiencing short-period oscillation.

PID Control Flow



- PID=OFF**
1. 10-03=0 (PID disabled)
 2. During JOG mode
 3. Multi-function digital input (03-00~03-05=29)

10-08	PID Offset	Default: 0
Range	【0】 : Positive 【1】 : Negative	

Parameter used to select the direction of PID Bias (10-09). Set to 0 for positive bias and 1 for negative bias adjustment.

10-09	PID bias	Default: 0
Range	【0-109】 %	

Parameter used to adjust the offset of the PID control. The offset value is added to the frequency reference as compensation. Use parameter 10-24 (PID output gain) to control the amount of compensation.

PID feedback loss detection

10-11	PID feedback loss detection selection	Default: 0
Range	【0】 : Disabled 【1】 : Warning 【2】 : Fault	
10-12	PID feedback loss detection level	Default: 0
Range	【0–100】 %	
10-13	PID feedback loss detection delay time	Default: 1
Range	【0.0–10.0】 Sec	

The PID control function provides closed-loop system control. In case PID feedback is lost, the AC Drive output frequency may be increased to the maximum output frequency. It is recommended to enable PID feedback loss when the PID function is used.

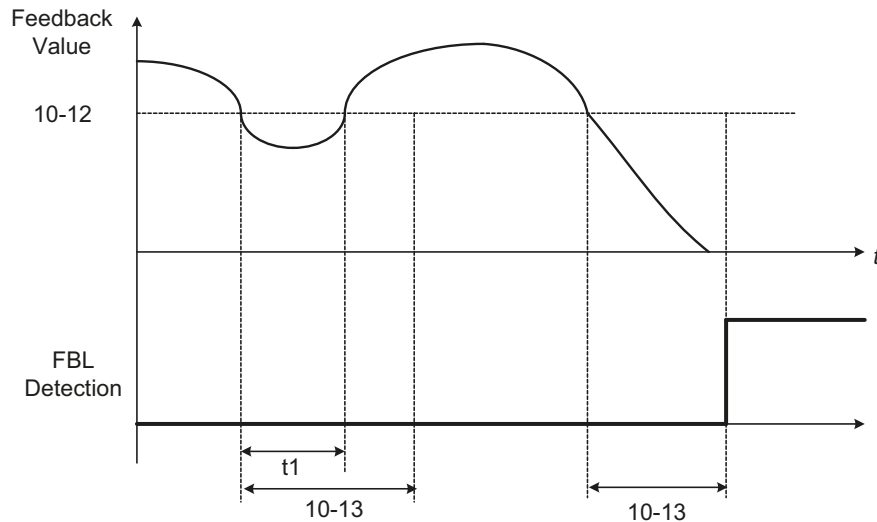
10-11=0: Disabled

10-11=1: Warning

A feedback loss condition is detected when the PID feedback value falls below the value set in parameter 10-12 (PID feedback loss detection level) for the time set in parameter 10-13 (PID feedback loss detection time). PID feedback loss warning message "Pb" will be displayed on the keypad and the AC Drive will continue to operate.

10-11=2: Fault

A feedback loss condition is detected when the PID feedback value falls below the value set in parameter 10-12 (PID feedback loss detection level) for the time set in parameter 10-13 (PID feedback loss detection time). PID feedback loss fault message "Pb" will be displayed on the keypad, the AC Drive stops and the fault contact is activated.



10-14	PID integral limit	Default: 100
Range	【0.0–100.0】 %	

Parameter used to limit the integral output to prevent motor stall or damage to the system in case of a rapid change in the feedback signal. Reduce the value of 10-14 to increase the AC Drive response.

10-15	PID Integrator Reset Delay	Default: 0
Range	【0–30】 Sec	

Parameter sets the delay in which the integrator is reset after PID feedback value reaches PID setpoint value.

Example:

10-15 is set to 5 seconds. When the PID feedback value reaches the PID setpoint value, the drive will wait 5 seconds before resetting the PID integrator.

10-16	PID Integrator Reset Deviation Range	Default: 0
Range	【0-100】 %	

Parameter sets the percent difference PID feedback value must be from PID setpoint for the integrator to restart. There is a $\pm 5\%$ tolerance.

PID Sleep Parameters

10-17	PID Sleep Start Frequency	Default: 0
Range	【0.00-599.00】 Hz	
10-18	PID Sleep Start Delay Time	Default: 0
Range	【0.0-255.5】 Sec	
10-19	PID Sleep Stop Frequency	Default: 0
Range	【0.00-599.00】 Hz	
10-20	PID Sleep Stop Delay Time	Default: 0
Range	【0.0-255.5】 Sec	

10-17 and 10-19: Parameter 01-02 must be set first.

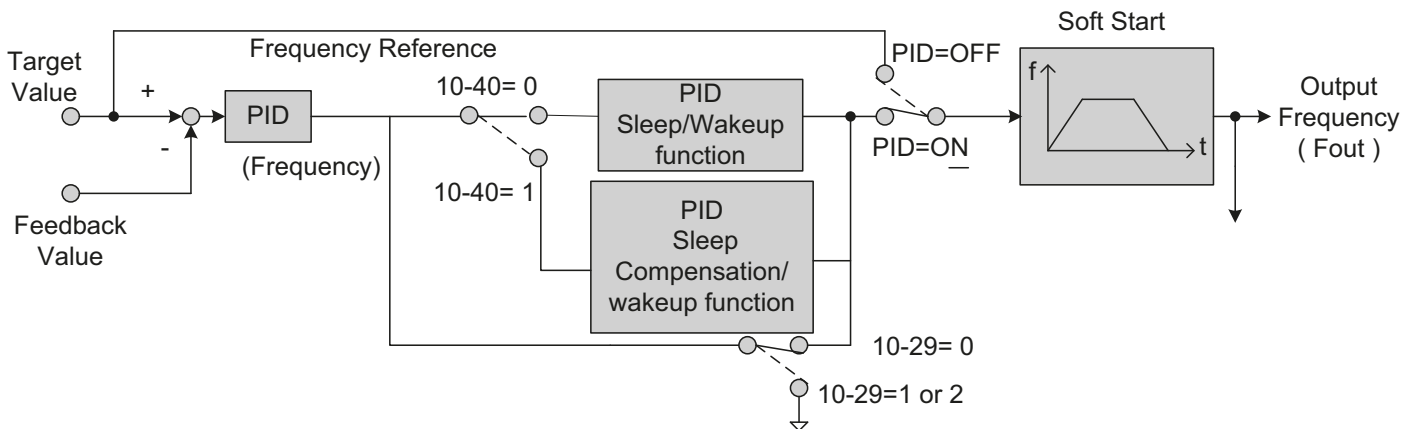
The PID Sleep function is used to stop the AC Drive when the PID output falls below the PID sleep frequency level (10-17) for the time specified in the PID sleep delay time parameter (10-18).

The AC Drive wakes up from a sleep condition when the PID output (Reference frequency) rises above the PID wake-up frequency level (10-19) for the time specified in the PID wake-up delay time (10-20).

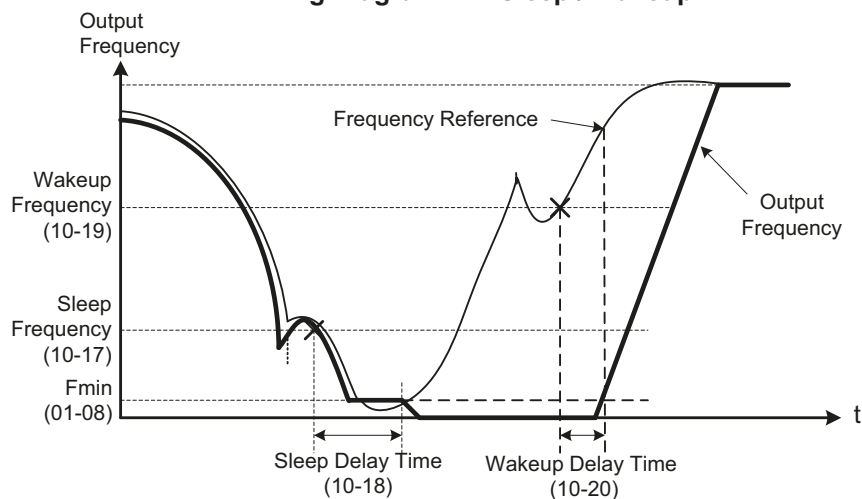
Set parameter 10-17 to a value greater than 0 to enable the PID sleep function.

Refer to figures below for PID sleep/wakeup operation:

PID Control Block Diagram



Timing Diagram PID Sleep / Wakeup



10-23	PID limit	Default: 100
Range	【0.0–100.0】 %	

Sets the PID output limit. Maximum output frequency is 100%.

10-24	PID output gain	Default: 1
Range	【0.0–25.0】	

Use parameter 10-24 to adjust PID output.

10-25	PID reversal output selection	Default: 0
Range	【0】 : Do not allow the reversal output 【1】 : Allow the reversal output	

In case the PID control output value goes negative, parameter 10-25 (PID reversal output selection) can be used to reverse the motor direction.

10-26	PID target acceleration / deceleration time	Default: 0
Range	【0.0–25.5】 Sec	

Sets the PID target value acceleration and deceleration ramp time. The acceleration/deceleration time is set by 00-14 to 00-17 and 00-21 to 00-24. Reduce the acceleration/deceleration time if load resonance or system instability is encountered.

10-27	PID Feedback Display Bias	Default: 0
Range	【0–9999】	

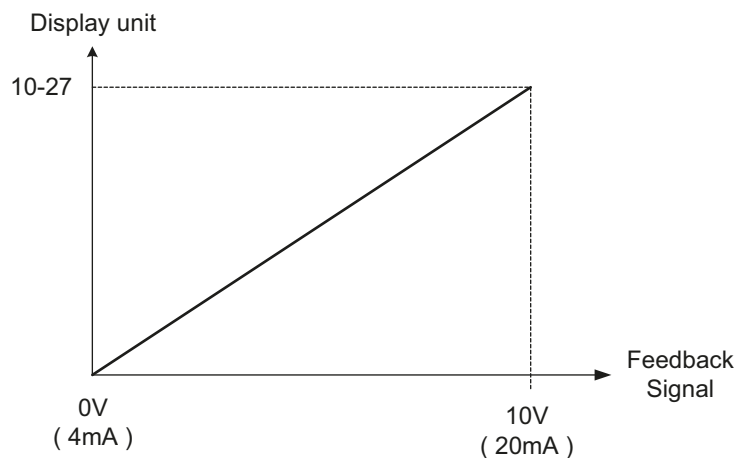
PID Feedback Display Scaling

The PID feedback signal can be scaled to represent actual engineering units.

Example:

Feedback signal is a pressure transducer (0-10V or 4-20mA) with a range of 0 – 20.0 PSI
4mA (0V) = 0 PSI, 20mA (10V) = 20.0 PSI. Set parameter 10-27 to 20.

Refer to the figure below for displaying the unit conversion.



10-29	PID sleep selection	Default: 1
Range	【0】 : Disabled 【1】 : Enabled 【2】 : Set by DI	

10-30	Upper Limit of PID Target	Default: 100
Range	【0–100】 %	
10-31	Lower Limit of PID Target	Default: 0
Range	【0–100】 %	

PID target value will be limited to the range specified in the upper & lower limit set by 10-30 and 10-31.

10-33	Maximum Value of PID Feedback	Default: 999
Range	【1–10000】	

100% of PID feedback equals value set in 10-33. Use 10-34 to adjust the scaling of parameter 10-33.

Note:

When using an LED keypad, 10-33 has to be set to a value lower than 1000 when 10-34=1, otherwise the keypad will show a SE05 alarm (PID setting error).

10-34	PID Value Scaling	Default: 1
Range	【0–4】	

Set PID target and feedback value scaling by controlling the position of the decimal point.

Example:

10-34=1, keypad displays XXX.X; 10-34=2, keypad displays XX.XX.

10-35	PID Unit	Default: 0
Range	【0–24】	

- | | | | | |
|--------|--------|--------|---------|---------|
| 0: % | 4: GPH | 8: /s | 12: inW | 16: CMM |
| 1: FPM | 5: GPM | 9: /m | 13: HP | 17: W |
| 2: CFM | 6: IN | 10: /h | 14: m/s | 18: KW |
| 3: PSI | 7: FT | 11: °F | 15: MPM | 19: m |

Select PID engineering unit (e.g. PSI) display depending on the application. Available only when using LCD keypad.

10-39	Output Frequency Setting of PID Disconnection	Default: 30
Range	【0.00–599.00】 Hz	

During a PID feedback loss condition the AC Drive will run at a fixed output frequency set by parameter 10-39. PID operation continues when feedback loss condition is no longer active.

10-40	PID Sleep Compensation Frequency	Default: 0
Range	【0】 : Disabled 【1】 : Enabled	

10-40=0, refer to above diagram “Timing Diagram PID Sleep / Wakeup”

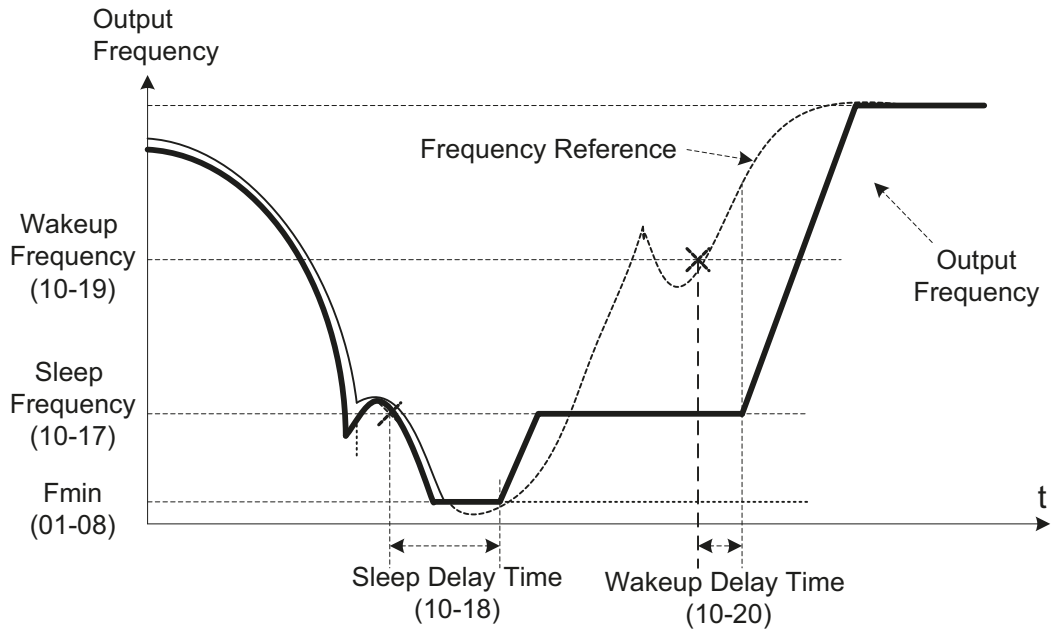
When the output frequency (Fout) falls below the PID sleep frequency (10-17) for the time specified in the PID sleep delay time (10-18) the AC Drive will decelerate to a stop and enter sleep mode.

10-40=1, refer to below diagram “Timing Diagram of PID Sleep Compensation / Wakeup”

When the output frequency (Fout) falls below the PID sleep frequency (10-17), the PID sleep timer starts and the AC Drive decelerates to the minimum output frequency (Fmin) set by 01-08. When the sleep timer expires the AC Drive will enter sleep mode and run at the sleep frequency set by 10-17.

While sleep mode is active and the motor has stopped, the internal PID control is still operating. When the reference frequency increases and exceeds the wakeup frequency parameter 10-19 for the time specified in the wakeup delay time parameter 10-20, the AC Drive will restart and the output frequency will ramp up to the reference frequency.

Timing Diagram PID Sleep Compensation / Wakeup



10-41	Differential Mode Enable	Default: 0
Range	【0】 : Disabled 【1】 : Enabled	
10-47	Fire Mode Proportional gain (P)	Default: 1.00
Range	【0.00–10.00】	
10-48	Fire Mode Integral time (I)	Default: 1.00
Range	【0.0–100.0】 Sec	
10-49	Fire Mode Differential time (D)	Default: 0.00
Range	【0.00–10.00】 Sec	

See parameter details for 10-05 through 10-07 for Fire Mode PID instructions. Fire Mode must be enabled first.

10-50	Derivative Filter	Default: 4
Range	【1–250】 ms	

Derivative Filter will delay the response of derivative feedback in the D Control PID Loop. Used to fine tune a system that experiences a lot of oscillation. Adjustment is not needed for most applications.

10-51	PID Integrator Tolerance	Default: 0
Range	【0–100】 %	

10-51 sets integrator tolerance level after being reset to 0.

PID Sleep Parameters

10-52	Accumulator Reset Mode	Default: 0
Range	【0】 : Disabled 【1】 : 1 Sec 【30】 : 30 Sec (Range: 0–30 Sec)	

10-52=0: Integral accumulator reset function is disabled.

10-52=1–30: When PID feedback value reaches the set point, the integral accumulator is reset after 1–30 seconds upon an AC Drive stop condition. The AC Drive will start running again based on the target and feedback value.

11 Auxiliary Parameters

11-00	Direction Lock Selection	Default: 0
Range	【0】 : Allow forward and reverse rotation 【1】 : Only allow forward rotation 【2】 : Only allow reverse rotation	

If Direction Lock parameter 11-01 is set to 1 or 2, the motor only operates in that specific direction. A run command for the opposite direction will run in the locked direction. Forward or reverse commands can be issued via the control terminals, keypad or communication.

Note:

This parameter can be used in fan and pump applications where reverse rotation is prohibited.

11-01	Carrier Frequency	Default: 5
Range	【1-16】 KHz	

Sets the AC Drive carrier frequency in kHz (IGBT switching frequency).

Notes:

- (1) Value 1 to 16 represents kHz.
- (2) Setting range depends on AC Drive rating (13-00) and HD/ND mode (00-27).
- (3) Refer to section 3.16, AC Drive derating based on carrier frequency.
- (4) A low carrier frequency increases motor noise but reduces motor losses and temperature.
- (5) A low carrier frequency decreases RFI, EMI interference and motor leakage current.
- (6) Reduce the carrier frequency if the torque does not match the speed.

Carrier Frequency	1KHz	6KHz	10KHz	16KHz
Motor noise	High ----- Low			
Output current waveform (similar to sinusoidal wave)	Fair ----- Good ----- Better			
Noise interference	Low ----- High			
Leakage current	Low ----- High			
Heat loss	Low ----- High			

If cable length between the AC Drive and the motor is too long, the high-frequency leakage current will cause an increase in AC Drive output current. This might affect peripheral devices. Adjust the carrier frequency to avoid this as shown in table below.

Wire length	< 30m (<98ft)	<50m (<164ft)	<100m (<328ft)	>100m (>328ft)
Carrier frequency (11-01 value)	Max value 16KHz (11-01=16KHz)	Max value 10KHz (11-01=10KHz)	Max value 5KHz (11-01=5KHz)	Max value 2KHz (11-01=2KHz)

11-02	Software PWM Function Selection	Default: 0
Range	【0】 : Disable 【1】 : Soft PWM 1 enabled 【2】 : Soft PWM 2 enabled	

11-02=0: Soft PWM control disabled.

11-02=1: Soft PWM 1 control enabled. Software PWM control can reduce audible and RFI noise produced by the motor. Software PWM 1 uses 3-phase modulation for higher torque and reduced noise but more heat generation.

11-02=2: Soft PWM 2 control enabled. Use parameters 11-66 (2/3 Phase PWM Switch Frequency), 11-67 (Soft PWM 2 Frequency Bias) and 11-68 (Soft PWM 2 Switch Frequency) to manually adjust for motor noise. Software PWM 2 modulates between 2 and 3 phase PWM for reduced heat generation but lower torque and less stable output speed.

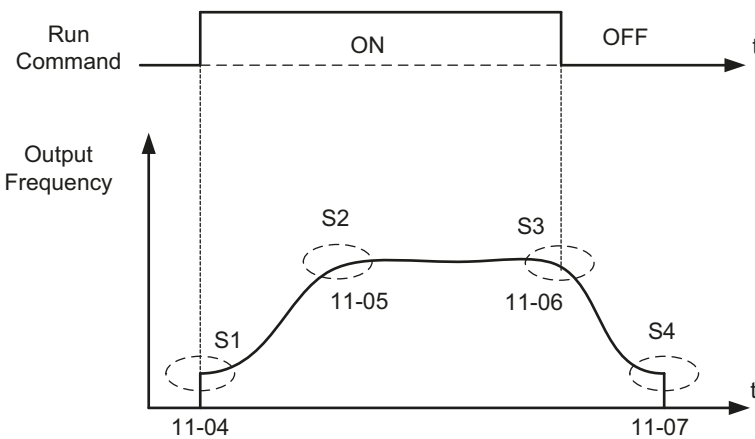
11-03	Automatic Carrier Lowering Selection	Default: 0
Range	【0】 : Disabled 【1】 : Enabled	

11-03=0: Automatic carrier frequency reduction during an overheat condition is disabled.

11-03=1: Carrier frequency is automatically lowered when AC Drive heatsink is overheated and will return to carrier frequency set in parameter 11-01 when temperature returns to normal. See section 3.16 for more information.

Param. #	Parameter Name	Default	Range
11-04	S-Curve Time Setting at Start of Acceleration	0.2	【0.00–2.50】 Sec
11-05	S-Curve Time Setting at End of Acceleration	0.2	
11-06	S-Curve Time Setting at Start of Deceleration	0.2	
11-07	S-Curve Time Setting at End of Deceleration	0.2	

The S-Curve function for acceleration / deceleration is used to reduce mechanical impact caused by the load during momentary starting and stopping of the AC Drive. To use the S curve function, set the time for acceleration start point (11-04), acceleration end point (11-05), deceleration start point (11-06) and deceleration end point (11-07). Refer to figure below for more information.



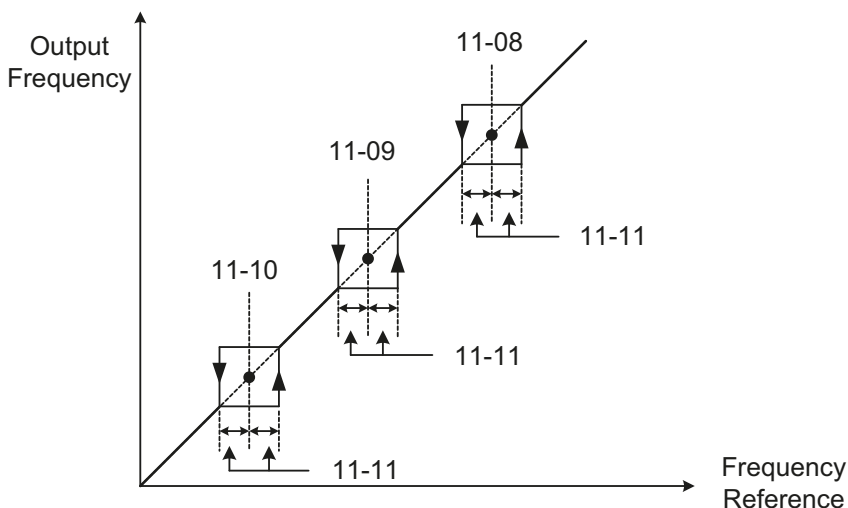
Total acceleration and deceleration time when the S curve is used:

$$\text{Accel. time} = \text{Accel. time 1 (or 2)} + \frac{(11-04) + (11-05)}{2}$$

$$\text{Decel. time} = \text{Decel. time 1 (or 2)} + \frac{(11-06) + (11-07)}{2}$$

Param. #	Parameter Name	Default	Range
11-08	Jump Frequency 1	0	【0.0–599.0】 Hz
11-09	Jump Frequency 2	0	
11-10	Jump Frequency 3	0	
11-11	Jump Frequency Width	1	【0.0–30.0】 Hz

These parameters allow “jumping over” certain frequencies that can cause unstable operation due to mechanical resonance in certain applications.



Note:

Prohibit any operation within the jump frequency range. During acceleration and deceleration the frequency is continuous without skipping the jump frequency.

To enable jump frequency 1 – 3 (11-08 – 11-10) set the frequency to a value greater than 0.0 Hz. Range is dependent on parameter 01-02.

Use the jump frequency width (11-11) to create a jump frequency range. Refer to figure at the left.

11-12	Manual Energy Saving Gain (VF)	Default: 80
Range	【0-100】 %	

Manual energy savings reduces the output voltage for the purpose of saving energy.

To enable manual energy savings set one of the multi-function digital inputs (03-00 to 03-05) to 20 and activate the input or use parameter 11-18 to set the manual energy savings activation frequency.

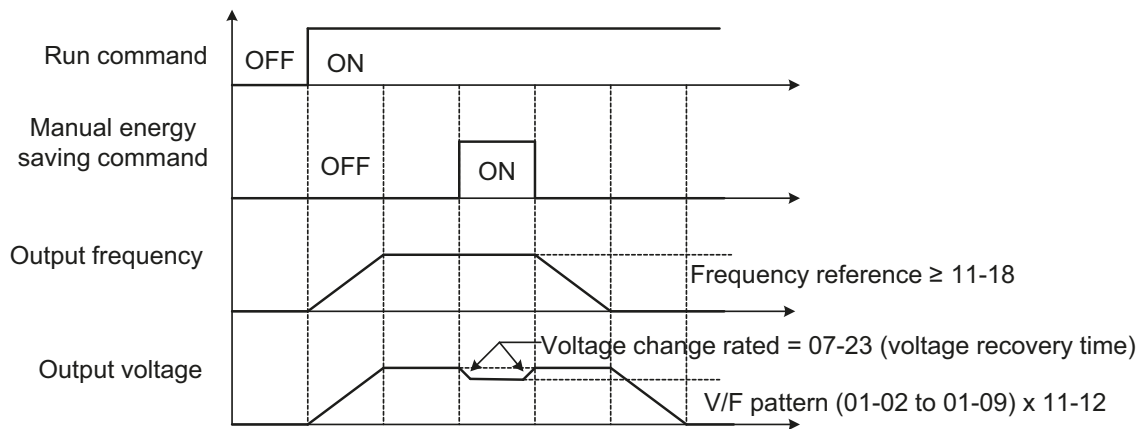
When the output frequency rises above the value set in parameter 11-18 manual energy savings function is enabled. Setting parameter 11-18 manual energy savings frequency to 0.0 Hz disables the manual energy savings frequency activation function. Refer to figure below for more information.

Note:

Only use manual energy savings functions in combination with light loads.

Manual energy saving gain (11-12) determines the output voltage of the AC Drive when manual energy savings is enabled. Output voltage is percentage gain times the V/F voltage.

Manual energy saving control uses the voltage recovery time (07-23) to change the output voltage, refer to figure below.



11-13	OV Prevention Selection	Default: 0
Range	【0】 : Disable 【1】 : OV Prevention Mode 1 【2】 : OV Prevention Mode 2 【3】 : OV Prevention Mode 3	

11-13=1: OV prevention Mode 1

1) DC voltage filter is used to provide a stable reference value for determining the change in DC voltage during regenerative operation.

- Adjust the DC voltage filtering increase rate parameter 11-33 (DC Voltage Filter Rise Amount). When the DC voltage exceeds 11-33 +11-35 (DC Voltage Filter Dead-band Level), the output of the filter will increase.

- Adjust the DC voltage filtering decrease rate parameter 11-34 (DC Voltage Filter Fall Amount). When the DC voltage exceeds 11-33 +11-35 (DC Voltage Filter Dead-band Level), the output of the filter will decrease.

- Monitor the DC voltage filter output using 12-20 (DC voltage filter value).

- Set the DC voltage filter decrease rate (11-34) to a greater value than that of the DC voltage filtering increase rate (11-33).

2) When the AC Drive is operating at a fixed output frequency, the OVP function will monitor the DC-bus voltage to detect regenerative operation.

During a regenerative condition, the AC Drive calculates delta DC bus voltage value and multiplies the value with parameter 11-36. The result is added to the frequency reference and accelerating the motor to prevent an overvoltage condition.

When the regenerative energy decreases, the AC Drive output frequency will return to the actual frequency reference. Deceleration rate is based on the DC voltage, as shown in figure below.

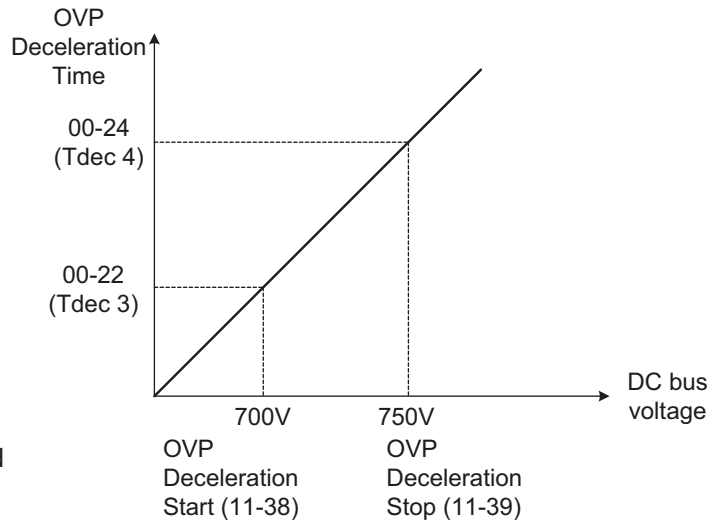
3) When the AC Drive is stopped, the deceleration rate can be set with parameter 00-15 (Tdec1). If the DC voltage is too high, the AC Drive will decelerate based on the OVP deceleration time as shown in the figure.

- Set DC-bus voltage in parameter 11-38 (start voltage of OVP deceleration) and set OVP deceleration rate in 00-22 (Tdec3).

- When the DC voltage reaches this level, it is necessary to decelerate rapidly in order to prevent the delta DC voltage becoming too large.

- When DC voltage reaches the setting of 11-39 (stop voltage of OVP deceleration), it will decelerate based on the set value of 00-24 (Tdec4)

- Deceleration rate is linear based on the slope defined by the start point (11-38) and end point (11-39).



4). Enable the OVP function with parameter 11-13 set to 1 or 2. The following parameter default values will be changed when the OVP function is enabled:

- 07-09=1 (Stop mode: coast to stop)
- 00-14(Tacc1) = 5.0 Sec (the frequency reference acceleration rate when DC voltage is too high.)
- 00-22(Tdec3) = 20.0 Sec (low setting point of OVP deceleration rate).
- 00-24(Tdec4) = 100.0 Sec (high setting point of OVP deceleration rate).

Note:

S curve should be disabled when using the OVP function (11-04–11-07=0.0sec).

11-13=2: OV prevention Mode 2

This mode is similar to OV prevention mode 1 but uses frequency gain of OV prevention 2 (11-28) in combination with the accel/decel times.

11-13=3: OV prevention Mode 3

In this mode the AC Drive will raise the output frequency temporarily to avoid an OV condition; the output frequency will not go higher than the value of 01-02 (Maximum Output Frequency of Motor 1). Please adjust the value of 01-02 according to application. Raise the value of 11-64 in increments of 0.1 if an OV condition still occurs when 11-13=3 is selected.

11-14	OV Prevention Level	Default: 370 or 740
Range	240V : 【200–400】 V 480V : 【400–800】 V	
11-17	Acceleration / Deceleration Gain	Default: 1
Range	【0.1–10.0】	

Parameter 11-14 sets the Regeneration prevention voltage level. If an “OV” condition still occurs when 11-13=3, increase the value of 11-17 in steps of 0.1 V.

Note:

If this level is set too low, over-voltage protection will not work properly, and the actual deceleration time will be extended.

Regeneration prevention response time can be adjusted by increasing 11-17. This will improve the response to voltage changes on the DC bus but may cause output frequency instability.

11-18	Manual Energy Saving Frequency	Default: 0
Range	【0.0–599.0】 Hz	

Manual energy savings reduces the output voltage for the purpose of saving energy.

To enable manual energy savings set one of the multi-function digital inputs (03-00 to 03-05) to 20 and activate the input or use parameter 11-18 to set the manual energy savings activation frequency.

When the output frequency rises above the value set in parameter 11-18 manual energy savings function is enabled. Setting parameter 11-18 manual energy savings frequency to 0.0 Hz disables the manual energy savings frequency activation function. Refer to parameter 11-12 for more information.

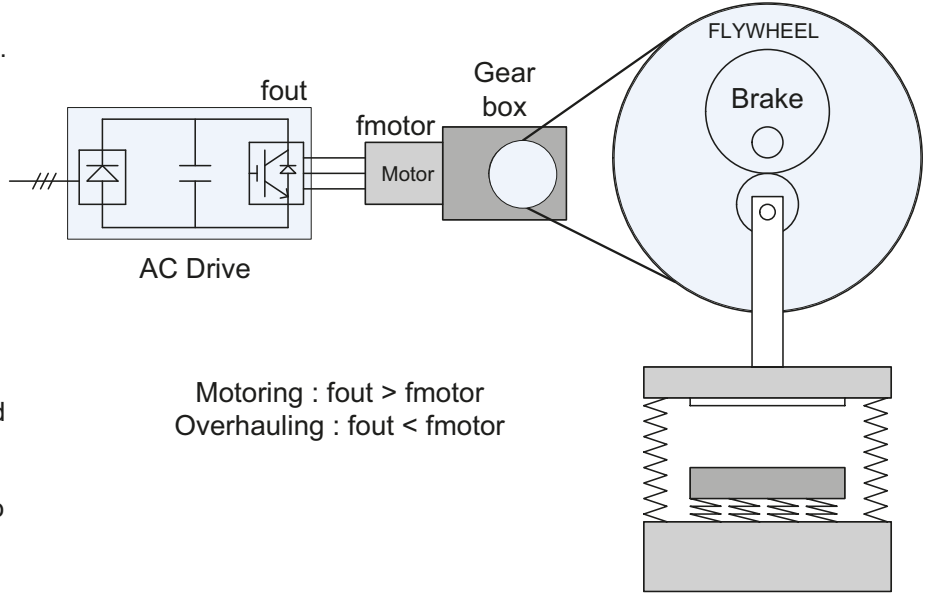
11-19	Automatic Energy Saving Function	Default: 0
Range	【0】 Disabled 【1】 Enabled	
11-20	Automatic Energy Saving Filter Time	Default: 140
Range	【0–200】 ms	
11-21	Energy Saving Tuning Voltage Upper Limit	Default: 100
Range	【0–100】 %	
11-22	Automatic Energy Saving Detection Level	Default: 20
Range	【0–5000】 ms	
11-23	Automatic Energy Saving Detection Level	Default: 10
Range	【0–100】 %	
11-24	Automatic Energy Saving Coefficient	Default: –
Range	【0.00–655.34】	
11-28	Frequency Gain of Over Voltage Prevention 2	Default: 100
Range	【1–200】 %	
11-33	DC Voltage Filter Rise Amount	Default: 0.1
Range	【0.1–10.0】 V	
11-34	DC Voltage Filter Fall Amount	Default: 5.0
Range	【0.1–10.0】 V	
11-35	DC Voltage Filter Dead-band Level	Default: 10.0
Range	【0.0–99.0】 V	
11-36	OV Prevention Frequency gain	Default: 0.050
Range	【0.000–1.000】	
11-37	OV Prevention Frequency limit	Default: 5.00
Range	【0.00–599.00】 Hz	
11-38	OV prevention Deceleration start voltage	Default: 300 or 600
Range	240V: 【200–400】 V 480V: 【400–800】 V	
11-39	OV Prevention Deceleration end voltage	Default: 350 or 700
Range	240V: 【300–400】 V 480V: 【600–800】 V	

Overvoltage suppression is used in applications that will likely cause regenerative energy. Please see the following example:

Example: Press Application

In this application there are two conditions causing regenerative energy back to the AC Drive and therefore recharging the DC bus.

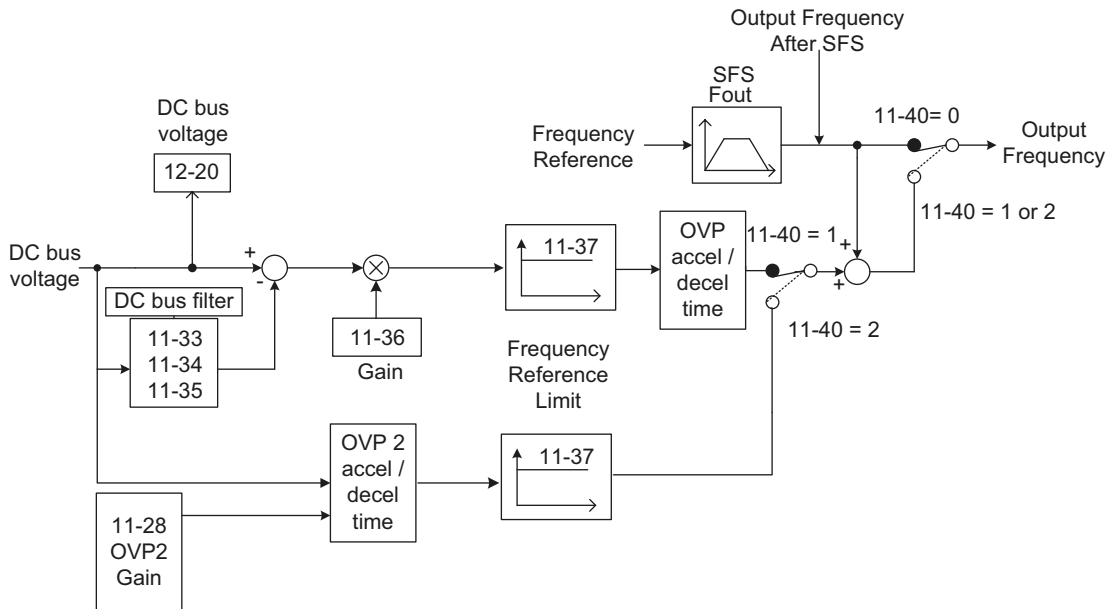
(1) When the brake is not set, the motor will accelerate and rotate the flywheel. When motor decelerates, the rotation speed will exceed the motor speed due to the large flywheel's inertia, feeding back regenerative energy to the AC Drive, and resulting in an increased DC bus.



(2) When the brake is set, the motor will rotate the flywheel and compress the spring. At the highest point when the press moves beyond its center, the spring will release its stored energy back to the flywheel, feeding back regenerative energy to the AC Drive resulting in an increased DC bus.

Over-voltage prevention (OVP) function monitors the DC-bus voltage and adjusts the speed reference, acceleration and deceleration rate, to prevent the AC Drive from tripping on an overvoltage condition.

When the speed reference is reduced, the motor will start to decelerate. When the AC Drive is operating at a fixed output frequency and excessive regenerative energy back to the AC Drive is detected the AC Drive will accelerate the motor in order to reduce the DC-bus voltage. Refer to figure below.



11-41	Reference Frequency Disappearance Detection	Default: 0
Range	【0】 : Decelerate to Stop when Reference Frequency Disappears 【1】 : Operation is set by Parameter 11-42 when Reference Frequency Disappears	
11-42	Reference Frequency Disappearance Level	Default: 80.0
Range	【0.0–100.0】	
11-43	Hold Frequency at Start	Default: 0.0
Range	【0.0–599.0】	
11-44	Frequency Hold Time at Start	Default: 0.0
Range	【0.0–10.0】	
11-45	Hold Frequency at Stop	Default: 0.0
Range	【0.0–599.0】	
11-46	Frequency Hold Time at Stop	Default: 0.0
Range	【0.0–10.0】	
11-47	KEB Deceleration Time	Default: 0
Range	240V : 【200–400】 V 480V : 【400–800】 V	
11-48	KEB Detection Level	Default: 200V or 480V
Range	【0.1–10.0】	

KEB function can be used to keep the AC Drive from tripping on an under voltage condition due to a momentary power-loss. To enable the KEB function, set parameter 11-47 to a value greater than 0.0 sec.

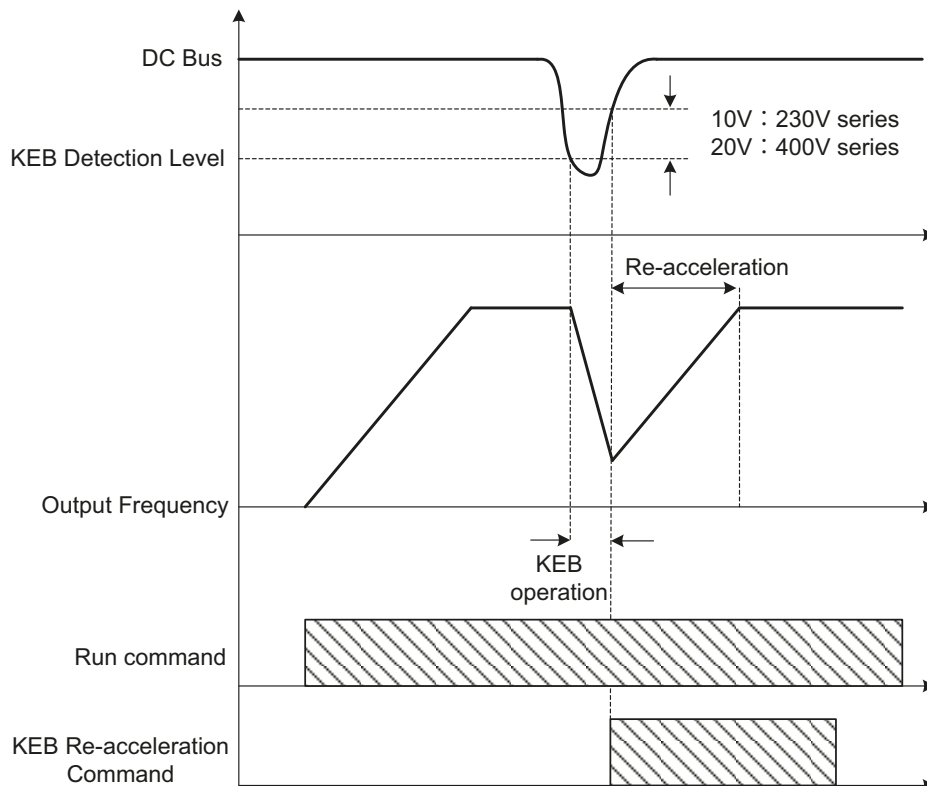
Upon detection of a power-loss the AC Drive uses the KEB deceleration time (11-47) to decelerate the motor and uses the regenerative energy from the motor to maintain the DC-bus at a nominal level.

11-48: KEB detection level

If the DC-bus voltage falls below the value set in 11-48, the KEB is activated and the AC Drive starts decelerating according to the value set in 11-47.

To accelerate back to the original output frequency, one of the digital inputs (03-00 to 03-05) set for 48 (KEB acceleration) has to be activated and the DC voltage has to rise above 11-48 + delta V (Delta V = +10V for 240V Class, Delta V = +20 V for 480V Class).

Example:



11-55	STOP Key Selection	Default: 1
Range	【0】 : Stop key is disabled when the operation command is not set to operator control 【1】 : Stop key is enabled when the operation command is not set to operator control	

This function can be used to enable or disable the stop key on keypad display when 00-02 is set to 1 (external terminal) or 00-02 is set to 3 (communication).

11-55= 0: Stop button disabled.

11-55= 1: Stop button enabled.

11-59	Gain of preventing Oscillation	Default: 0.00
Range	【0.00–2.50】	

This parameter is used to prevent motor oscillation (hunting).

If oscillation occurs under normal operation (normal duty mode), increase the setting value by 0.01 increments.

11-60	Upper Limit of Preventing Oscillation	Default: 100
Range	【0–100】 %	

Motor oscillation (hunting) prevention upper limit.

11-61	Time Parameter of Preventing Oscillation	Default: 0
Range	【0–100】	

The delay time used to prevent motor oscillation.

11-62	Oscillation Prevention	Default: 1
Range	【0】 : Mode 1 【1】 : Mode 2 【2】 : Mode 3	

11-62=0: Mode 1, lower response to prevent oscillation.

11-62=1: Mode 2, medium response to prevent oscillation.

11-62=2: Mode 3, fast response to prevent oscillation.

11-63	Strong Magnetic Selection	Default: 1
Range	【0】 : Disable 【1】 : Enable	

11-63=0: No adjustment of the magnetizing current. The magnetizing current is the same at low and high speeds.

11-63=1: Magnetizing current is automatically increased at lower speed (increase in motor torque). Best used in constant torque applications where increased starting torque is required.

11-66	2/3 Phase PWM Switch Frequency	Default: 20
Range	【6.00–60.00】	

AC Drive will modulate mode from 2 phase PWM to 3 phase PWM when the output frequency is higher than the value set in parameter 11-66.

11-67	Soft PWM 2 Frequency Bias	Default: 0
Range	【0–12000】	
11-68	Soft PWM 2 Switch Frequency	Default: 20
Range	【6.00–60.00】 Hz	

Noise detection function is enabled when the AC Drive output frequency rises above the value set in parameter 11-68. The AC Drive will change the electromagnetic noise in operation according to the PWM mode setting of parameter 11-02.

Notes:

When 11-02=2, the sum of 11-01 and 11-67 cannot be higher than the upper limit of carrier frequency, please refer to the error conditions:

An error message is shown when parameter 11-02=2 and the sum of 11-66 and 11-67 is higher than the upper limit of the carrier frequency. Adjust the value of 11-02 or 11-67.

11-69	Gain of Preventing Oscillation 2	Default: 5
Range	【0.00–200.00】 %	

Increase value in steps of 0.01 in case of motor vibration in ND mode.

11-70	Upper Limit of Preventing Oscillation 2	Default: 5
Range	【0.01–100】 %	

Set upper limit for the oscillation prevention function.

11-71	Time Parameter of Preventing Oscillation 2	Default: 100
Range	【0–30000】 ms	

Set oscillation 2 prevention response time. A lower value increases response time but may cause instability.

11-72	Switching Frequency 1 of Preventing Oscillation 2	Default: 30
Range	【0.01–300.00】 Hz	

11-73	Switching Frequency 2 of Preventing Oscillation 2	Default: 50
Range	【0.01–300.00】 Hz	

Parameters 11-72 and 11-73 define the oscillation prevention mode switching frequencies.

12 Monitoring Parameters

12-00	Display Screen Selection (LED)	Default: 321
Range	0 0 0 0 0 MSD LSD 00000–88888 Each digit can be set from 0 to 8 as listed below. 【0】 : No display 【1】 : Output current 【2】 : No display 【3】 : DC bus voltage 【4】 : heatsink temperature 【5】 : PID feedback 【6】 : AI1 value 【7】 : AI2 value 【8】 : Counter	

Note:

The highest bit is used for power-up monitor. The 4 least significant bits can be used to customize the display sequence.

12-01	PID Feedback Display Mode (LED)	Default: 0
Range	【0】 : Display the feedback value as integer (xxx) 【1】 : Display the feedback value with one decimal (xx.x) 【2】 : Display the feedback value with two decimals (x.xx)	
12-02	PID Feedback Display Unit Setting (LED)	Default: 0
Range	【0】 : xxxxx (no unit) 【1】 : xxxPb (pressure) 【2】 : xxxFL (flow)	
12-03	Line Speed Display (LED)	Default: 1500 / 1800
Range	【0-60000】 RPM	

Set motor rated RPM for the AC Drive to display the actual motor speed based on the output frequency.
Motor synchronous speed = 120 x Rated frequency ÷ Number of poles.

12-04	Line Speed Display Mode (LED)	Default: 0
Range	【0】 : Display AC Drive Output Frequency 【1】 : Line Speed Display at Integer. (xxxxx) 【2】 : Line Speed Display at One Decimal Place. (xxxx.x) 【3】 : Line Speed Display at Two Decimal Places. (xxx.xx) 【4】 : Line Speed Display at Three Decimal Places. (xx.xxx)	

12-04#0, line speed is always displayed in run or stop mode. Set 12-03 to the maximum line speed that corresponds to the maximum output frequency.

Example:

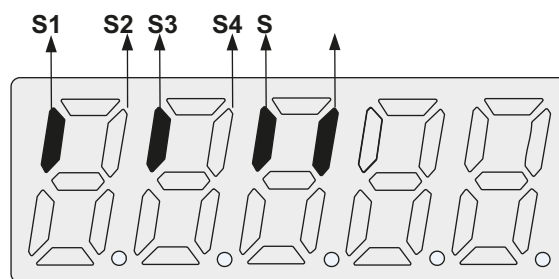
12-03 = 1800, the keypad display will show 900 when the output frequency is 30Hz on a 60Hz drive.

12-05	Status display of digital input terminal (LED/LCD)	Default: -
Range	Read-only	

Terminals S1-S6 are represented using two segments of each digit. Segment turns on when input is active. The bottom segments of each of the first three digits are used to represent the digital outputs (R1, R2). Segments turn on when output is active.

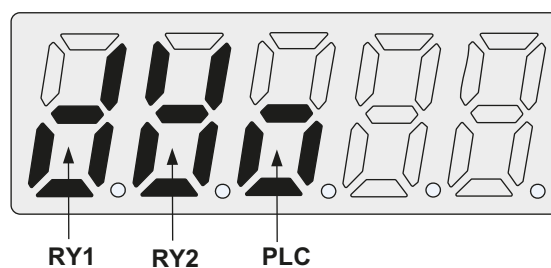
Example 1:

S1/S3/S5/S6 are ON, S2/S4 are OFF, 12-05 will turn on when RY1 without output. (LED)

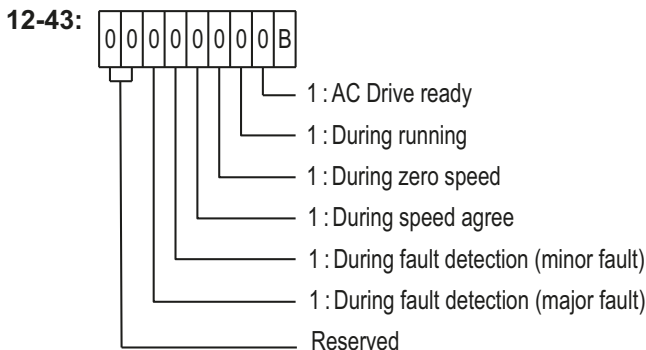


Example 2:

S2/S3/S4 are ON, S1/S5/S6 are OFF, RY1/RY2 outputs are turned on.



12-06	Output Current	Default: –
Range	Read-only	
12-07	Output Power	Default: –
Range	Read-only	
12-11	Output Current of Current Fault	Default: –
Range	Read-only	
12-12	Output Voltage of Current Fault	Default: –
Range	Read-only	
12-13	Output Frequency of Current Fault	Default: –
Range	Read-only	
12-14	DC Voltage of Current Fault	Default: –
Range	Read-only	
12-15	Frequency Command of Current Fault	Default: –
Range	Read-only	
12-16	Frequency Command	Default: –
Range	Read-only	
12-17	Output Frequency	Default: –
Range	Read-only	
12-19	Output Voltage	Default: –
Range	Read-only	
12-20	DC Voltage (VDC)	Default: –
Range	Read-only	
12-28	Motor Torque Current (Iq)	Default: –
Range	Read-only	
12-29	Motor Excitation Current (Id)	Default: –
Range	Read-only	
12-36	PID Input	Default: –
Range	Read-only	
12-37	PID Output	Default: –
Range	Read-only	
12-38	PID Setting	Default: –
Range	Read-only	
12-39	PID Feedback	Default: –
Range	Read-only	
12-41	Heatsink Temperature	Default: –
Range	Read-only	
12-43	AC Drive Status	Default: –
Range	Read-only	



Note:
12-43 digits are 0 by default and will change to 1 depending on conditions shown in the diagram.

Parameter is displayed in binary.

12-74	Reserved	Default: –
Range	Reserved	
12-75	Reserved	Default: –
Range	Reserved	
12-82	Motor Load	Default: –
Range	Read-only	

13 Maintenance Parameters

13-00	AC Drive Capacity Selection	Default: Per Model
Range	See Table Below	

AC Drive Model	13-00 Display	AC Drive Model	13-00 Display
TD400-20P5-13PH	2P5	TD400-4001-3PH	401
TD400-2001-13PH	201	TD400-4002-3PH	402
TD400-2002-13PH	202	TD400-4003-3PH	403
TD400-2003-13PH	203	TD400-4005-3PH	405
TD400-2005-3PH	205	TD400-47P5-3PH	408
TD400-27P5-3PH	208	TD400-4010-3PH	410
TD400-2010-3PH	210	TD400-4015-3PH	415
TD400-2015-3PH	215	TD400-4020-3PH	420
TD400-2020-3PH	220	TD400-4025-3PH	425
TD400-2025-3PH	225	TD400-4030-3PH	430
TD400-2030-3PH	230	TD400-4040-3PH	440
TD400-2040-3PH	240	TD400-4050-3PH	450
		TD400-4060-3PH	460
		TD400-4075-3PH	475

13-01	Software Version	Default: Per Model
Range	----	
13-02	Fault Record	Default: 0
Range	----	
13-03	Cumulative Operation Hours 1	Default: Per Model
Range	【0–23】 hours	
13-04	Cumulative Operation Hours 2	Default: Per Model
Range	【0–65535】 days	
13-05	Cumulative Operation Time	Default: 0
Range	【0】 : Accumulative operation time while power on 【0】 : Accumulative operation time when it is operating	

13-05=0: AC Drive logs the time when the AC Drive is powered-up.

13-05=1: AC Drive logs the time when the AC Drive is running.

13-06	Parameters lock	Default: 2
Range	【0】 : Parameters are read-only except 13-06 and main frequency 【1】 : Reserved 【2】 : Advanced level, all parameters are accessible	



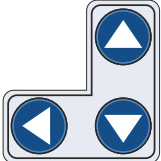



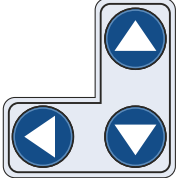



Note:

Main frequency is displayed in 12-16. The value shown is equal to frequency setting of speed-stage 0 (05-01)

13-07	Parameter Lock Key Code	Default: 0
Range	【00000–65534】	



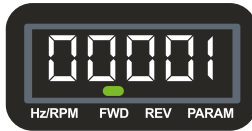
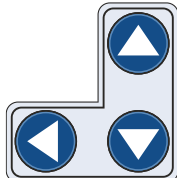


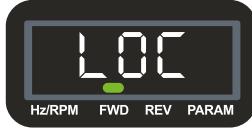
When parameter lock key code is enabled (13-07>0), all parameters except the main frequency cannot be modified.

Setting a Password

Step	Key	Display
3. Press MODE/PROG to enter program mode.		
4. Use arrow keys to change parameter to 13-07.		
7. Press READ/ENTER key to edit parameter 13-07.*		
8. Use the navigation keys to set a password. For this example we will use 12345.		
11. Press READ/ENTER key to save the parameter. Display will flash -END-.		



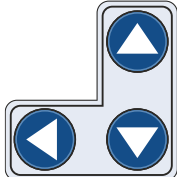




Password has been saved but AC Drive is not locked.

Locking the AC Drive

Step	Key	Display
7. Press READ/ENTER key to edit parameter 13-07.*		
8. Display will show 00001 indicating a password is set but AC Drive is not locked.		
8. Use the navigation keys to enter the password we set earlier (12345).		
11. Press READ/ENTER key to lock the AC Drive. Display will flash LOC.		

The AC Drive is now locked.

Unlocking the AC Drive with key code (password)

Step	Key	Display	Step	Key	Display
7. Press READ/ENTER key to edit parameter 13-07.*			8. Use the navigation keys to enter the password we set earlier (12345).		
8. Display will show 00002 indicating a password is set and AC Drive is locked.			11. Press READ/ENTER key to unlock the AC Drive Display will flash -END-.		

The AC Drive is now unlocked.

Note:

When the AC Drive is unlocked, the saved password is deleted. User must set a new password before re-locking the AC Drive.

The same procedure can be used to lock fire mode parameters 08-48 to 08-59 by substituting parameter 13-07 for 08-60.

13-08	Restore factory setting / initialize	Default: Per Model
Range	<p>【1】 : 2 wires initialization (50Hz) (220V/380V)</p> <p>【2】 : 2 wires initialization (60Hz) (220V/380V)</p> <p>【3】 : 2 wires initialization (50Hz) (230V/400V)</p> <p>【4】 : 2 wires initialization (60Hz) (240V/480V)</p> <p>【5】 : 2 wires initialization (50Hz) (220V/415V)</p> <p>【6】 : 2 wires initialization (60Hz) (230V/400V)</p> <p>【7】 : 2 wires initialization (50Hz) (220V/440V)</p> <p>【8】 : 2 wires initialization (60Hz) (220V/440V)</p> <p>【1112】 : PLC initialization (RESET)</p>	

Use parameter 13-08 to initialize the AC Drive to factory default. It is recommended to write down the modified parameters before initializing the AC Drive. After initialization, the value of 13-08 will return to zero automatically

13-08=1: 2 Wire Initialization (220V/380V)

Multi-function digital input terminal S1 controls forward operation / stop command and S2 controls reverse operation / stop command. AC Drive input voltage (01-14) is automatically set to 220V (240V class) or 380V (480V class). When 01-00 (V/F curve) = F, 01-02 will automatically be set to 50Hz.

13-08=2: 2 Wire initialization (220V/380V)

Multi-function digital input terminal S1 controls forward operation / stop command, and S2 controls reverse operation / stop command. AC Drive input voltage (01-14) is automatically set to 220V (240V class) or 380V (480V class). When 01-00 (V/F curve) = F, 01-02 will automatically set to 60Hz.

13-08=3: 2 Wire Initialization (230V/400V)

Multi-function digital input terminal S1 controls forward operation / stop command, and S2 controls reverse operation / stop command. AC Drive input voltage (01-14) is automatically set to 220V (240V class) or 400V (480V class). When 01-00 (V/F curve) = F, 01-02 will automatically set to 50Hz.

13-08=4: 2 Wire Initialization (240V/480V)

Multi-function digital input terminal S1 controls forward operation / stop command, and S2 controls reverse operation / stop command. AC Drive input voltage (01-14) is automatically set to 220V (240V class) or 460V (480V class). When 01-00 (V/F curve) = F, 01-02 will automatically set to 60Hz.

13-08=5: 2 Wire Initialization (220V /415V)

Multi-function digital input terminal S1 controls forward operation / stop command, and S2 controls reverse operation / stop command. AC Drive input voltage (01-14) is automatically set to 220V (220V class) or 415V (440V class). When 01-00 (V/F curve) = F, 01-02 will automatically set to 50Hz.

13-08=6: 2 Wire Initialization (230V/400V)

Multi-function digital input terminal S1 controls forward operation / stop command, and S2 controls reverse operation / stop command. AC Drive input voltage (01-14) is automatically set to 230V (220V class) or 400V (440V class). When 01-00 (V/F curve) = F, 01-02 will automatically set to 60Hz.

13-08=7: 2 Wire Initialization (220V/440V)

Multi-function digital input terminal S1 controls forward operation / stop command, and S2 controls reverse operation / stop command. AC Drive input voltage (01-14) is automatically set to 220V (220V class) or 440V (440V class). When 01-00 (V/F curve) = F, 01-02 will automatically set to 50Hz.

13-08=8: 2 Wire Initialization (220V/440V)

Multi-function digital input terminal S1 controls forward operation / stop command, and S2 controls reverse operation / stop command. AC Drive input voltage (01-14) is automatically set to 220V (220V class) or 440V (440V class). When 01-00 (V/F curve) = F, 01-02 will automatically set to 60Hz.

13-08=1112: PLC Initialization

Clear built-in PLC ladder logic and related values.

The following parameters are not affected parameter 13-08 Restore to Factory / Initialization

Number	Parameters
00-00	Control Mode Selection
00-34	Language
00-27	HD/ND Mode Selection
01-00	V/F Curve Selection
01-26	V/F Curve of Motor 2
13-00	AC Drive Capacity Selection
13-03	Cumulative Operation Hours 1
13-04	Cumulative Operation Hours 2
13-05	Cumulative Operation Time

13-10	Parameter Password Function 2	Default: 0
Range	Read-only	
13-51	Hour Meter Reset	Default: 0
Range	【0】 : Do not clear Cumulative Operation Hours 【1】 : Clear Cumulative Operation Hours	

14 PLC Parameters

Param. #	Parameter Name	Default	Range
14-00	T1 set value 1	0	【0-9999】
14-01	T1 set value 2 (mode 7)	0	
14-02	T2 set value 1	0	
14-03	T2 set value 2 (mode 7)	0	
14-04	T3 set value 1	0	
14-05	T3 set value 2 (mode 7)	0	
14-06	T4 set value 1	0	

Param. #	Parameter Name	Default	Range
14-07	T4 set value 2 (mode 7)	0	【0-9999】
14-08	T5 set value 1	0	
14-09	T5 set value 2 (mode 7)	0	
14-10	T6 set value 1	0	
14-11	T6 set value 2 (mode 7)	0	
14-12	T7 set value 1	0	
14-13	T7 set value 2 (mode 7)	0	
14-14	T8 set value 1	0	
14-15	T8 set value 2 (mode 7)	0	
14-16	C1 set value	0	【0-65535】
14-17	C2 set value	0	
14-18	C3 set value	0	
14-19	C4 set value	0	
14-20	C5 set value	0	
14-21	C6 set value	0	
14-22	C7 set value	0	
14-23	C8 set value	0	
14-24	AS1 set value 1	0	
14-25	AS1 set value 2	0	
14-26	AS1 set value 3	0	
14-27	AS2 set value 1	0	
14-28	AS2 set value 2	0	
14-29	AS2 set value 3	0	
14-30	AS3 set value 1	0	
14-31	AS3 set value 2	0	
14-32	AS3 set value 3	0	
14-33	AS4 set value 1	0	
14-34	AS4 set value 2	0	
14-35	AS4 set value 3	0	
14-36	MD1 set value 1	1	
14-37	MD1 set value 2	1	
14-38	MD1 set value 3	1	
14-39	MD2 set value 1	1	
14-40	MD2 set value 2	1	
14-41	MD2 set value 3	1	
14-42	MD3 set value 1	1	
14-43	MD3 set value 2	1	
14-44	MD3 set value 3	1	
14-45	MD4 set value 1	1	
14-46	MD4 set value 2	1	
14-47	MD4 set value 3	1	

Please refer to section 5 for more details on built-in PLC function.

15 PLC Monitoring Parameters

Param. #	Parameter Name	Default	Range
15-00	T1 Current Value1	0	【0-9999】
15-01	T1 Current Value 2 (Mode7)	0	
15-02	T2 Current Value 1	0	
15-03	T2 Current Value 2 (Mode7)	0	
15-04	T3 Current Value 1	0	
15-05	T3 Current Value 2 (Mode7)	0	
15-06	T4 Current Value 1	0	
15-07	T4 Current Value 2 (Mode7)	0	
15-08	T5 Current Value 1	0	
15-09	T5 Current Value 2 (Mode7)	0	
15-10	T6 Current Value 1	0	
15-11	T6 Current Value 2 (Mode7)	0	
15-12	T7 Current Value 1	0	
15-13	T7 Current Value 2 (Mode7)	0	
15-14	T8 Current Value 1	0	
15-15	T8 Current Value 2 (Mode7)	0	
15-16	C1 Current Value	0	【0-65535】
15-17	C2 Current Value	0	
15-18	C3 Current Value	0	
15-19	C4 Current Value	0	
15-20	C5 Current Value	0	
15-21	C6 Current Value	0	
15-22	C7 Current Value	0	
15-23	C8 Current Value	0	
15-24	AS1 Current Value	0	
15-25	AS2 Current Value	0	
15-26	AS3 Current Value	0	
15-27	AS4 Current Value	0	
15-28	MD1 Current Value	0	
15-29	MD2 Current Value	0	
15-30	MD3 Current Value	0	
15-31	MD4 Current Value	0	
15-32	TD Current Value	0	

16 LCD Parameters

Note:

LCD Copy Keypad is an optional keypad for remote mounting only.

16-00	Main Screen Monitoring	Default: 16
Range	【5-43】	
16-01	Sub-Screen Monitoring 1	Default: 17
Range	【5-43】	
16-02	Sub-Screen Monitoring 2	Default: 18
Range	【5-43】	

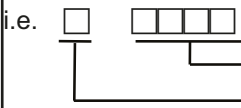




At power-up the AC Drive shows two monitor sections on the display, main monitor section consisting of one monitor (large font) and a sub-screen monitor section consisting of two monitors (smaller font).

Choose the monitor signal to be displayed on the main-screen monitor screen using parameter 16-00, and the monitor signals to be displayed on the sub-screen monitor with parameters 16-01 and 16-02, similar to monitor parameters 12-5 – 12-43.

16-03	Display Unit	Default: 0	
Range	【0】 : Frequency display unit is Hz (Resolution is 0.01Hz) 【1】 : Frequency display unit is % (Resolution is 0.01%) 【2】 : Frequency display unit is rpm 【3-39】 : Reserved 【40-9999】 : 100% is XXXX with no decimals (integer only) 【10001-19999】 : 100% is XXX.X with 1 decimal 【20001-29999】 : 100% is XX.XX with 2 decimals 【30001-39999】 : 100% is X.XXX with 3 decimals		
16-04	Engineering Unit	Default: 0	
Range	【0】 : No Unit 【6】 : IN 【12】 : inW 【18】 : KW 【1】 : FPM 【7】 : FT 【13】 : HP 【19】 : m 【2】 : CFM 【8】 : /s 【14】 : m/s 【20】 : °C 【3】 : PSI 【9】 : /m 【15】 : MPM 【21】 : RPM 【4】 : GPH 【10】 : /h 【16】 : CMM 【22】 : Bar 【5】 : GPM 【11】 : °F 【17】 : W 【23】 : Pa		

16-03: Display unit of digital operator

Set the units of the following items to be displayed, the frequency reference (05-01, 00-18, 06-01-06-15) and the monitoring frequency 12-16, 12-17 (Output frequency)

00040 - 39999	Set the decimal point by using the fifth place i.e. 			
	Sets full display scaling excluding decimals Set the number of decimal places			
	00040 - 09999:  (Integer only e.g. 1000)			
	10001 - 19999:  (1 decimal place e.g. 10.0)			
	20001 - 29999:  (2 decimal places, e.g. 10.00)			
30001 - 39999:  (3 decimal places, e.g. 10.000)				
<Example>:				
	16-03	Display	Display Unit	Display example
	00040-09999	□□□□	Use 16-04 Setting	Example: 100 % speed is 0200 > set 16-03=00200 (from 05-01, 06-01 to 06-15, set range from 0040 to 9999). > set 16-04=0 (no unit)
	10001-19999	□□□. □		Example: 100 % speed is 200.0 CFM > set 16-03=12000 (05-01, 06-01 to 06-15, set range from 0000 to 9999). > set 16-04=2 (CFM) > 60% speed will be displayed as 120.0 CFM
	20001-29999	□□. □□		Example: 100 % speed is 65.00°C > set 16-03=26500 (05-01, 06-01 to 06-15, set range from 0000 to 9999) > set 16-04=20 (°C) > 60% of speed is displayed as 39.00 °C
	30001- 9999	□. □□□		Example: 100 % speed is 2.555 m/s > set 16-03=32555 > set 16-04=14 (m/s) > 60% speed is displayed as 1.533 m/s

16-04: Display unit of engineering

When 16-03 = 00040 to 39999, engineering units are enabled. The displayed set range and the frequency range of unit (05-01, 06-01–06-15) as well as the monitoring frequency (12-16, 12-17) are changed by parameters 16-04 and 16-03.

16-05	LCD Backlight	Default: 5
Range	【0–7】	

Adjust the screen backlight of the digital operator. If set to 0, the screen backlight is turned off.

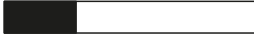

16-07	Copy Function Selection	Default: 0
Range	【0】 : Do not copy parameter 【1】 : Read AC Drive parameters and save to the keypad 【2】 : Write the keypad parameters to AC Drive 【3】 : Compare parameters of AC Drive and keypad	
16-08	Allowing Reading	Default: 0
Range	【0】 : Do not allow to read AC Drive parameters and save to the keypad 【1】 : Allow to read AC Drive parameters and save to the keypad	

LCD digital operator with built-in memory (EEPROM) can be used to store and retrieve parameters:



- (1) Read: Save AC Drive parameters to the digital operator (INV → OP).
- (2) Write: Write the parameters from the digital operator to the AC Drive and save (OP → INV).
- (3) Verify: Compare the AC Drive parameters against the parameters in the digital operator. (OP ↔ INV)

16-07=0: No action

16-07=1: Read (all parameters are copied from the AC Drive to the keypad). See table below for an example.



Step	LCD Display	Description
1	Group 14 PLC Setting 15 PLC Monitor 16 LCD Keypad Func.	Select function group (16) from the group menu.
2	PARA 16 -07 : Copy Sel -08 : READ Sel -09 : Keypad Loss Sel	Press the Read / Enter key and select parameter (16-07) copy sel.
3	Edit 16-07 Copy Sel ----- <input type="checkbox"/> Normal (0 – 3) < 0 >	Press the Read / Enter key to change value of 16-07.
4	Edit 16-07 Copy Sel ----- <input checked="" type="checkbox"/> READ (0 – 3) < 0 >	Change the set value to 1 (READ) by using the up arrow key.
5	-ADV- READ INV → OP 	(1) Use Read / Enter key to enable the read operation. (2) The bottom of LCD display will show a status bar to indicate the read progress.
6	-ADV- READ COMPLETE 	"READ COMPLETE" will be displayed on the keypad when read operation was successful.
	RDP Read Prohibited	(1) The error message of "RDP Read Prohibited" is displayed when reading parameters from the AC Drive is prohibited. (2) If this error is displayed, press any key to continue go back to parameter 16-07.
7	Edit 16-07 Copy Sel ----- <input checked="" type="checkbox"/> READ (0 – 3) < 0 >	When DSP/FUN key is pressed, the display returns back to parameter 16-07.

16-07=2: Write (all parameter are copied from the keypad to the AC Drive). See table below for an example.

Step	LCD Display	Description
1	Group 14 PLC Setting 15 PLC Monitor 16 LCD Keypad Func.	Select function group (16) from the group menu.
2	PARA 16 -07 : Copy Sel -08 : READ Sel -09 : Keypad Loss Sel	Press the Read / Enter key and select parameter (16-07) copy sel.
3	Edit 16-07 Copy Sel ----- <input type="radio"/> Normal (0 - 3) < 0 >	Press the Read / Enter key to change value of 16-07. Press the Read / Enter key to change value of 16-07.
4	Edit 16-07 Copy Sel ----- <input checked="" type="radio"/> WRITE (0 - 3) < 0 >	Change the set value to 2 (WRITE) by using the up arrow key.
5	-ADV- WRITE INV → OP 	(1) Use Read / Enter key to enable the write operation. (2) The bottom of LCD display will show a status bar to indicate the read progress.
6	-ADV- WRITE COMPLETE 	"WRITE COMPLETE" will be displayed on the keypad when write operation was successful.
	WRE Write Error	(1) The error message of "WRE Write Error" is displayed when writing parameters to the AC Drive is prohibited. (2) If this error is displayed, press any key to continue go back to parameter 16-07.
7	Edit 16-07 Copy Sel ----- <input checked="" type="radio"/> WRITE (0 - 3) < 0 >	When DSP/FUN key is pressed, the display returns back to parameter 16-07.

16-07=3: Verify (Compare the set value of the AC Drive to the parameter of the digital operator).

Step	LCD Display	Description
1	Group 14 PLC Setting 15 PLC Monitor 16 LCD Keypad Func.	Select function group (16) from the group menu.
2	PARA 16 -07 : Copy Sel -08 : READ Sel -09 : Keypad Loss Sel	Press the Read / Enter key and select parameter (16-07) copy sel.
3	Edit 16-07 Copy Sel ----- <input type="radio"/> Normal (0 - 3) < 0 >	Press the Read / Enter key to change value of 16-07.

Step	LCD Display	Description
4	Edit 16-07 Copy Sel <hr/> 3 VERIFY (0 - 3) < 0 >	Change the set value to 3 (VERIFY) by using the up arrow key.
5	-ADV- VERIFY INV → OP 	(1) Use Read / Enter key to enable the write operation. (2) The bottom of LCD display will show a status bar to indicate the read progress.
6	-ADV- VERIFY COMPLETE 	"VERIFY COMPLETE" will be displayed on the keypad when parameter compare was successful.
	VERY Verify Error	(1) The error message of "VERY Verify Error" is displayed when writing parameters to the AC Drive is prohibited. (2) If this error is displayed, press any key to continue go back to parameter 16-07.
7	Edit 16-07 Copy Sel <hr/> 3 VERIFY (0 - 3) < 0 >	When DSP/FUN key is pressed, the display returns back to parameter 16-07.

Set 16-08 = 0, to prevent the saved parameter data stored in the digital operator from accidentally being overwritten.

When parameter 16-08=0 and the read operation is executed (16-07=1) a warning message of "RDP Read Prohibited" will be displayed on the keypad and the read operation is cancelled.

Note: Parameters other than those related to motor control can be copied to different sizes of TD400 than the model they were copied from. (e.g. input terminal functions, relay output functions, communication parameters, etc.).

16-09	Operator Removed	Default: 0
Range	【0】 : Continue operation when keypad is removed 【1】 : Trip AC Drive when keypad is removed while operating in local mode	

16-09=0: Continue operation when keypad is removed.

16-09=1: Trip AC Drive when keypad is removed while operating in local mode.

17 Automatic Tuning Parameters

17-00	Mode of automatic tuning	Default: V/F:2, SLV: 6
Range	【0】 : Rotational auto-tuning 【1】 : Static auto-tuning 【2】 : Stator resistance measurement 【3】 : Reserved 【4】 : Loop tuning 【5】 : Rotational Auto-tuning Combination (Item: 4+2+0) 【6】 : Static Auto-tuning Combination (Item: 4+2+1)	
17-01	Motor rated output power	Default: Per Model
Range	【0.00–600.00】 KW	

17-02	Motor rated current	Default: Per Model
Range	VF mode : 10%–120% of the AC Drive rated current SLV mode : 25%–120% of the AC Drive rated current	
17-03	Motor rated voltage	Default: Per Model
Range	240V: 【50.0–240.0】 V 480V: 【100.0–480.0】 V	
17-04	Motor rated frequency	Default: Per Model
Range	【5.0–599.00】 Hz	
17-05	Motor rated speed	Default: Per Model
Range	【0–24000】 rpm	
17-06	Pole number of motor	Default: 4
Range	【2–16】 pole	
17-08	Motor no-load voltage	Default: –
Range	240V: 【50–240】 V 480V: 【100–480】 V	
17-09	Motor excitation current	Default: –
Range	【15–70】 % of motor rated current	
17-10	Automatic tuning start	Default: 0
Range	【0】 : Disabled 【1】 : Enabled	
17-11	Error History of Automatic Tuning	Default: 0
Range	【0】 : No error 【1】 : Motor data error 【2】 : Stator resistance tuning error 【3】 : Leakage induction tuning error 【4】 : Rotor resistance tuning error 【5】 : Mutual induction tuning error 【6】 : DT error 【7】 : Encoder error 【8】 : Motor's acceleration error 【9】 : Warning	
17-12	Proportion of Motor Leakage Inductance	Default: Per Model
Range	【0.1–15.0】 %	
17-13	Motor Slip Frequency	Default: Per Model
Range	【0.10–20.00】 Hz	
17-14	Rotational Auto-tuning	Default: 0
Range	【0】 : V/F type rotational auto-tuning 【1】 : Vector type rotational auto-tuning	

*2. The setting range of motor rated frequency is 0.0 to 400.0 Hz in HD Mode (00-27=0), 0.0 to 120.0 Hz in ND Mode (00-27=1) and 0.0 to 599.0 Hz when using a custom V/F curve.

Auto-tuning

Using data from motor nameplate, set motor rated output power (17-01), motor output rated current (17-02), motor rated voltage (17-03), motor rated frequency (17-04), motor rated speed (17-05) and number of motor poles (17-06) to perform an auto-tune.

Using specifications from a motor less than 50% the size of the drive may cause an auto-tune error. Be sure to size drive appropriately to the motor for an accurate auto-tune.

Rotational auto-tuning (17-00=0)

Perform rotational auto-tune (High performance auto-tune)

WARNING: Uncouple motor from load and ensure rotor is free to rotate before performing rotational auto-tune.

Static auto-tuning (17-00=1)

Motor does not rotate during auto-tuning. This tuning method causes lower torque at low speed.

Stator resistance measurement (17-00=2)

Stator resistance non-rotational auto-tune (V/F mode only). Use when motor leads are longer than 165ft (50m).

Loop tuning (17-00=4)

Performance improvement (speed and torque regulation) in vector control mode. Useful for PID applications.

Rotational Auto-tuning Combination (17-00=5) *Recommended Method*

This tuning mode is a combination of three auto-tuning modes, Loop tuning (17-00=4), Stator resistance tuning (17-00=2) and Rotational auto-tuning (17-00=0). This method will produce the most accurate tune. Motor must be uncoupled from load before performing Rotational Auto-tuning Combination.

WARNING: Uncouple motor from load and ensure rotor is free to rotate before performing rotational auto-tune.

Static Auto-tune Combination (17-00=6)

This tuning mode is a combination of three auto-tuning modes, Loop tuning (17-00=4), Stator resistance measurement (17-00=2) and Static auto-tuning (17-00=1). This method is slightly less accurate than Rotational Auto-tuning Combination and may lack adequate low speed control or the motor may respond erratically when tune is finished. This method does not require uncoupling the motor from the load as rotor will not turn during tuning. If tuning results are ineffective, uncouple load from motor and run 17-00=5 "Rotational Auto-tuning Combination".

Motor rated output power (17-01)

Set motor power rating based on the motor nameplate, input range depends on the AC Drive rating (13-00).

The default value of this parameter will be changed by different capacities of AC Drive. It is recommended that HD/ND mode (00-27) be selected first before motor performs auto-tuning.

Motor rated current (17-02)

(1) Set motor FLA based on the motor nameplate, input range depends on the AC Drive rating (13-00).

(2) In V/F mode, range is 10–120 % of the AC Drive rated current.

(3) In SLV mode, range is 25–120% of the AC Drive rated current.

The default value of this parameter will be changed by different capacities of AC Drive. It is recommended that HD/ND mode (00-27) be selected first before performing auto-tuning.

Motor rated voltage (17-03)

Set motor voltage based on the motor nameplate. If motor rated voltage is higher than AC Drive input voltage, seek technical support guidance.

Motor rated frequency (17-04)

Set motor base frequency based on the motor nameplate.

Motor rated speed (17-05)

Set motor base speed frequency based on the motor nameplate.

The default value of this parameter will be changed by different capacities of AC Drive. It is recommended that HD/ND mode (00-27) be selected first before motor performs auto-tuning.

Number of poles (17-06)

Set number of motor poles, range is 2–16 poles.

Motor no-load voltage (17-08)

Do not adjust without technical support guidance.

Motor excitation current (17-09)

Do not adjust without technical support guidance.

Automatic Tuning Error History (17-11)

(1) If auto-tuning fails, the keypad will display the AtErr" message and the error cause is shown in parameter 17-11.

(2) Refer to Chapter 10 for error troubleshooting and possible causes.

(3) Error history only saves error from the last auto-tune. History will not show an error when auto-tune is aborted or if last auto-tune was successful.

Proportion of Motor Leakage Inductance (17-12)

- (1) Parameter can only be set when using stator resistance auto tuning (17-00=2).
- (2) Static non-rotational and rotational type auto tuning automatically measure the proportion of motor leakage inductance, therefore this parameter is not active in these tuning modes.
- (3) Default value is 4%. It is required to perform an auto tune to save the adjusted value into parameter 02-33.

Motor Slip Frequency (17-13)

- (1) Parameter can only be set when using stator resistance auto tuning (17-00=2).
- (2) Static non-rotational and rotational type auto tuning automatically measure the proportion of motor leakage inductance, therefore this parameter is not active in these tuning modes.
- (3) It is required to perform an auto tune to save the adjusted value into parameter 02-34.

Example:

We will assume the motor has the following specifications:

Attribute	Specification
Rated Power	0.746 KW
FLA	5.21A
Voltage	230VAC
Frequency	60Hz
RPM	1750
Poles	4

Given the above information, the following parameters will need to be set:

Parameter #	Parameter Name	Default	New Value
00-00	Control Mode Selection	0: V/F	2: SLV
17-00	Automatic Tuning Mode	6: Static Combination Tune	5: Rotational Combination Tune
17-01	Motor Rated Power	Varies	0.756 KW
17-02	Motor Rated Current	Varies	5.21 A
17-03	Motor Rated Voltage	230VAC	230VAC
17-04	Motor Rated Frequency	60Hz	60Hz
17-05	Motor Rated Speed	Varies	1750 RPM
17-06	Motor Poles	4	4

After all the above parameters have been set, change parameter 17-10=1. Display will show:



Press the RUN key to start auto-tuning procedure. Display will show scrolling:



When auto-tuning procedure is complete, display will show:



Warning:

Ensure that the motor is free from obstacles before running rotational auto tuning. Spinning rotor can cause property damage and serious injury or death.

Rotational Auto-tuning (17-14)

- (1) The parameter can only be set when rotational auto-tuning (17-00=0) or rotational auto-tuning combination (17-00=5) is selected.
- (2) VF type rotational auto-tuning (17-14=0) is best suited for unloaded induction motors
- (3) Vector type rotational auto-tuning (17-14=1) is best suited for unloaded vector duty induction motors. This tuning mode can be used for high speed motors. Use Vector type rotational auto-tuning if VF type rotational auto-tuning (17-14=0) is unsuccessful.
- (4) Vector type rotational auto-tuning (17-14=1) measures the motor no-loading current to avoid motor current oscillation that can be present in V/F mode.

18 Slip Compensation Parameters

18-00	Slip compensation gain at low speed	Default: VF:0.00, SLV: –
Range	【0.00–2.50】	
18-01	Slip compensation gain at high speed	Default: 0
Range	【-1.00–1.00】	
18-02	Slip compensation limit	Default: 200
Range	【0–250】 %	
18-03	Slip compensation filter	Default: 1
Range	【0.0–10.0】 Sec	
18-04	Regenerating slip compensation selection	Default: 0
Range	【0】 : Disabled 【1】 : Enabled	
18-05	FOC delay time	Default: 100
Range	【1–1000】 ms	
18-06	FOC gain	Default: 0.1
Range	【0.00–2.00】	

Slip compensation automatically adjusts the output frequency based on the motor load to improve the speed accuracy of the motor mainly in V/F mode.

The slip compensation function compensates for the motor slip to match the actual motor speed to the reference frequency.

Slip compensation adjustment in V/F mode

18-00: Slip compensation gain at low speed

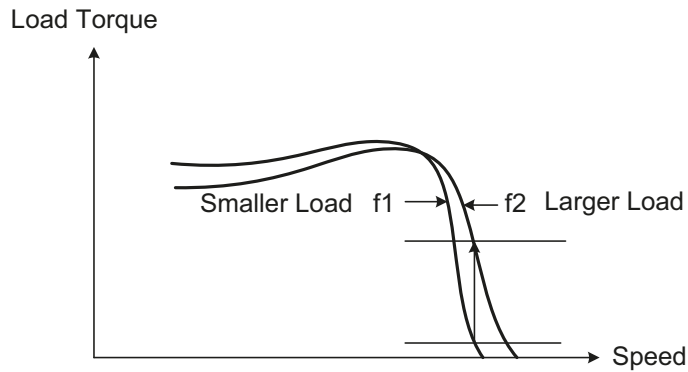
The adjustment of slip compensation gain at low speed follows the below procedure:

1. Set the rated slip and the motor no-load current (02-00).
2. Set the slip compensation (18-00) to 1.0 (factory default setting is 0.0 in V / F control mode)
3. For the operation with a load attached, measure the speed and adjust the slip gain (18-00) accordingly (increase in steps of 0.1).
 - If the motor speed is lower than frequency reference, increase the value of 18-00.
 - If the motor speed is higher than frequency reference, decrease the value of 18-00.

When the output current is greater than the no-load current (02-00), slip compensation is enabled and the output frequency increases from f1 to f2. Refer to figure below. The slip compensation value is calculated as follows:

$$\text{Slip Compensation Value} = \text{Motor rated slip frequency} \times \frac{[\text{Output current (12-18)} - \text{no-load current of Motor 1 (02-00)}]}{[\text{Rated current of Motor 1(02-01)} - \text{no-load current of Motor 1 (02-00)}]}$$

$$\text{Motor Rated Slip Frequency (f)} = \frac{(\text{Motor no-load synchronous speed} - \text{Motor full load rated speed})(N) \times \text{Motor Poles (P)}}{120}$$



Note:

Default depends on value of parameter 13-00.

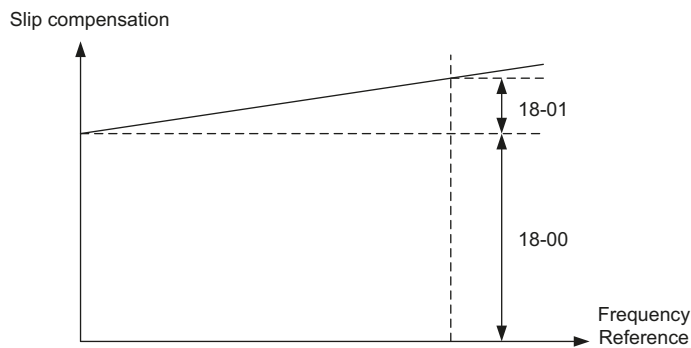
18-01: Slip compensation gain at high speed

- (1) It is not required to adjust the Slip compensation gain at high speed for a loaded motor.
- (2) After adjusting parameter 18-00 it is recommended to increase the reference frequency and check the motor speed. Increase the value of 18-01 to adjust the slip compensation in case the motor speed does not match.
- (3) To reduce speed errors increase the motor rated frequency (01-12 base frequency) and increase the value of 18-01.
- (3) Compared to 18-00, 18-01 serves as a variable gain for the full speed range.
- (4) If the speed accuracy becomes worse due to an increase in motor temperature, it is recommended to use a combination of 18-00 and 18-01 to adjust motor slip.

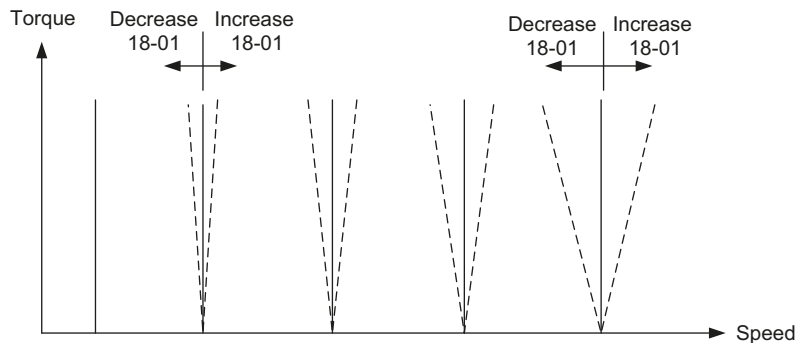
Parameter 18-01 determines the slip compensation at the motor rated speed and is calculated as follows:

$$\text{Slip Compensation Gain} = (\text{Slip Compensation Gain at low speed} + \text{Slip Compensation Gain at high speed}) \times \frac{\text{Reference Frequency}}{\text{Motor rated frequency (01-12)}}$$

Slip Compensation Gain Versus Frequency Reference

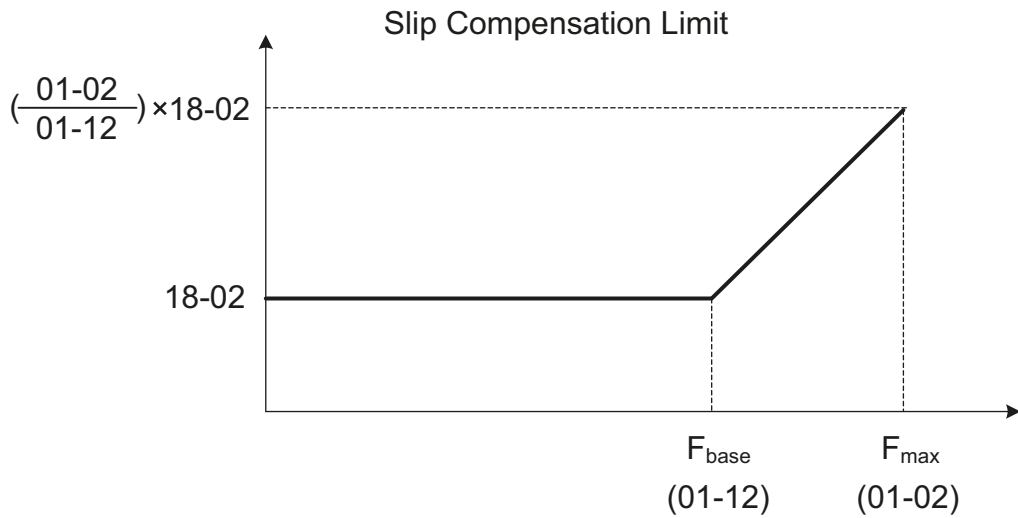


Parameter 18-01 effect on speed/torque curve



18-02: Slip compensation limit

Sets slip compensation limit in constant torque and the constant power operation, see figure below. If 18-02 is set to 0%, the slip compensation limit is disabled.



When the slip compensation gain 18-00 at low speed is adjusted, and the actual motor speed is still lower than the reference frequency, the motor may be limited by the slip compensation limit.

18-03: Slip compensation filter

Sets slip compensation filter time in V/F mode

18-04: Regenerating slip compensation selection

Enable or disable slip compensation during regeneration.

Enable slip compensation during regeneration (18-04=1) in case speed accuracy is required when experiencing regeneration caused by deceleration (SLV mode). When the slip compensation function is used, regenerative energy might increase temporarily (18-04=1) and a braking module might be required.

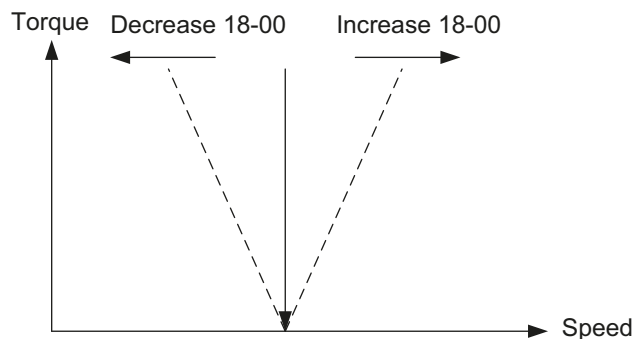
SLV mode adjustment

18-00: Slip compensation gain

- a) Slip compensation can be used to control the full range speed accuracy under load condition.
- b) If the output frequency is lower than 2 Hz and the motor speed decreases, increase the value of 18-00.
- c) If the output frequency is lower than 2 Hz and the motor speed increases, reduce the value of 18-00.

Slip compensation gain uses a single value for the full speed range. As a result, the slip compensation accuracy at low speed is high but slight inaccuracies might occur at high speeds. Slip compensation gain is fixed for the full speed range. Adjust 18-00 or 18-01 to improve speed accuracy at higher speed, however adjusting these parameters might impact the accuracy at lower speeds.

The impact of 18-00 on the speed and torque are shown in figure below.



18-05: FOC (Flux Orient Control) delay time (18-05)

In the SLV mode, the slip compensation of the magnetic flux depends on the torque current and excitation current. If the motor load rises above 100% while running at motor rated frequency, the motor voltage and resistance drop sharply, which may cause the AC Drive output to saturate and current jitter may occur.

The magnetic flux slip compensation will independently control the torque current and the excitation current to prevent increasing and decreasing of the current (jitter). For slow speed or fixed speed operation, 18-05 may be increased. For fast operation adjust 18-06.

18-06: Slip compensation gain (18-06)

If the motor is jittering at the rated frequency under full load, the value of 18-06 may gradually be reduced to zero to reduce current jitter.

20 Speed Control Parameters

20-00	ASR gain 1	Default: SLV: 6, PMSLV: 3
Range	【0.00–250.00】	
20-01	ASR integral time 1	Default: SLV: 0.5, PMSLV: 0.08
Range	【0.001–10.000】 Sec	
20-02	ASR gain 2	Default: SLV: 6, PMSLV: 3
Range	【0.00–250.00】	
20-03	ASR integral time 2	Default: SLV: 0.5, PMSLV: 0.6
Range	【0.001–10.000】 Sec	
20-04	ASR integral time limit	Default: 200
Range	【0–300】 %	
20-07	Acceleration and deceleration of P/PI	Default: 0
Range	【0】 : PI speed control will be enabled only in constant speed. For the speed acceleration and deceleration, only use P control. 【1】 : Speed control is enabled either in acceleration or deceleration.	
20-08	ASR delay time	Default: 0.004
Range	【0.000–0.500】 Sec	
20-09	Speed Observer Proportional(P) Gain1	Default: 0.61
Range	【0.00–2.55】	
20-10	Speed Observer Integral(I) Time 1	Default: 0.05
Range	【0.01–10.00】 Sec	
20-11	Speed Observer Proportional(P) Gain2	Default: 0.61
Range	【0.00–2.55】	
20-12	Speed Observer Integral(I) Time 2	Default: 0.06
Range	【0.01–10.00】 Sec	
20-13	Low-pass filter Time constant of speed feedback 1	Default: 4
Range	【1–1000】 ms	
20-14	Low-pass filter Time constant of speed feedback 2	Default: 30
Range	【1–1000】 ms	
20-15	ASR gain change frequency 1	Default: 4
Range	【0.0–599.0】 Hz	
20-16	ASR gain change frequency 2	Default: 8
Range	【0.0–599.0】 Hz	

20-17	Torque compensation gain at low speed	Default: 1
Range	【0.00–2.50】	
20-18	Torque compensation gain at high speed	Default: 0
Range	【-10–10】 %	
20-33	Detection Level at Constant Speed	Default: 1
Range	【0.1–5.0】 %	

20-00 to 20-06: Values will depend on motor data.

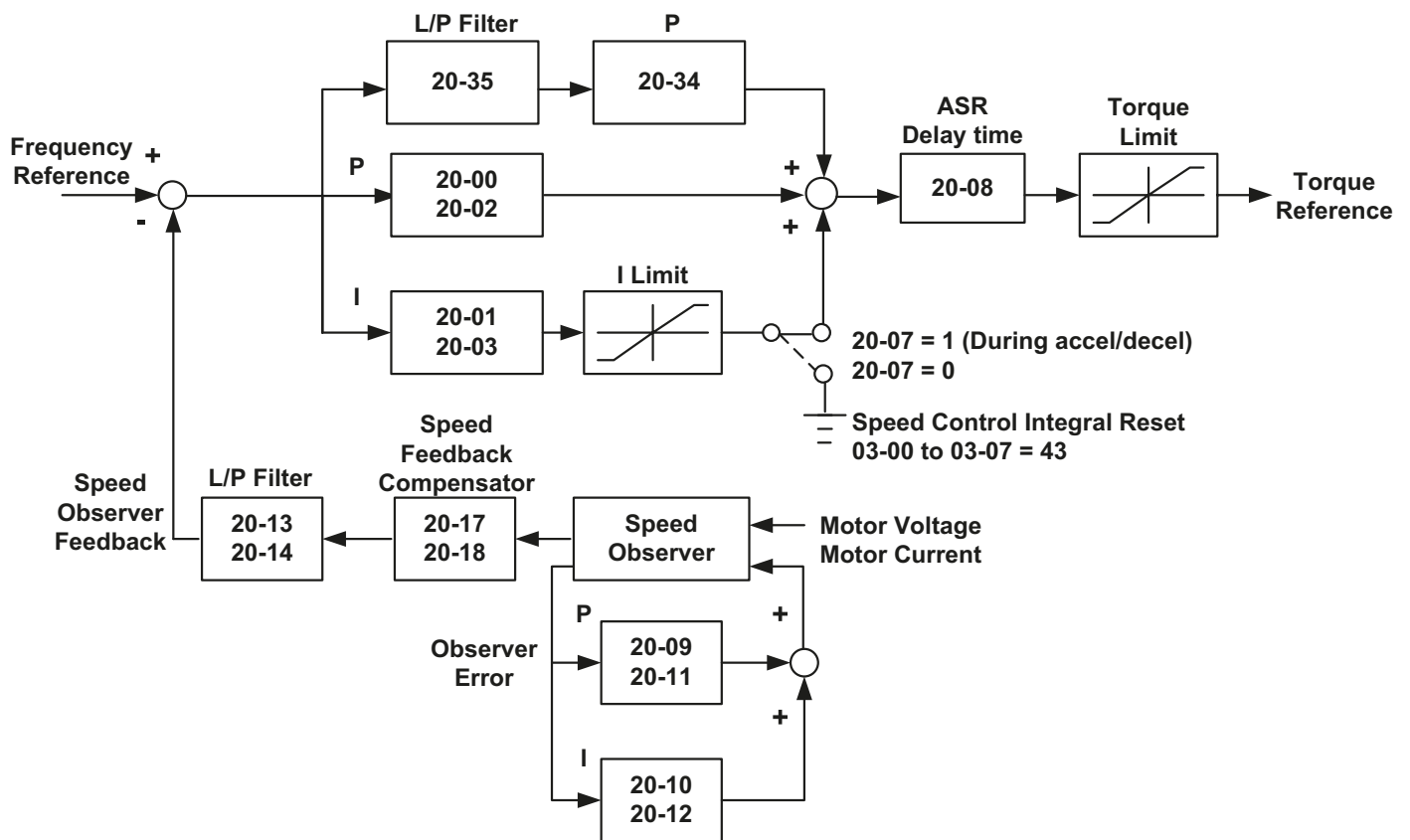
Parameter 20-33 is used when 20-07 is set to 0 and frequency command source is set to analog input. A noisy analog input signal might cause a problem where the AC Drive determines that the operation does not reach its constant speed. Adjust parameter 20-33 accordingly to avoid this situation from occurring.

The following diagram is an overview of the Automatic Speed Regulator (ASR) block.

SLV control mode:

The ASR function adjusts the output frequency to control the motor speed to minimize the difference between the frequency reference and actual motor speed.

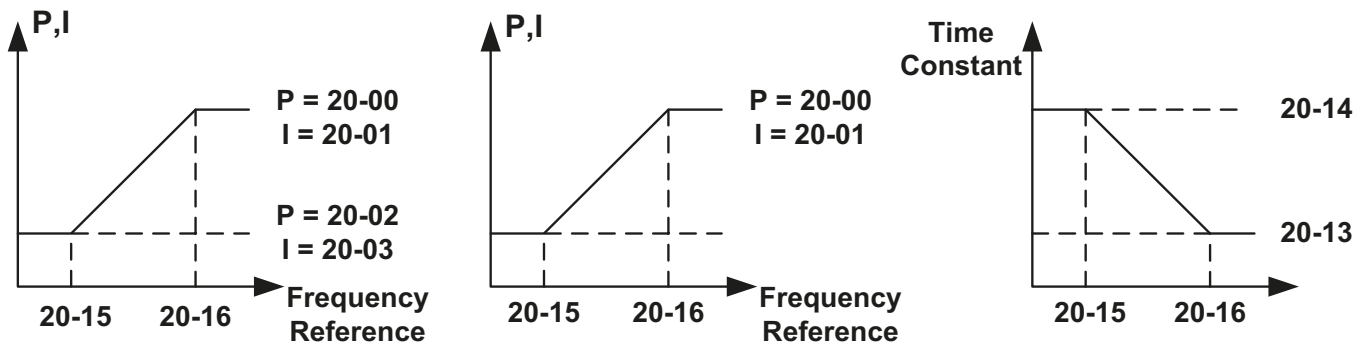
The ASR controller in SLV mode uses a speed estimator to estimate the motor speed. In order to reduce speed feedback signal interference, a low-pass filter and speed feedback compensator can be enabled.



ASR Setting (SLV/PMSLV control mode)

In SLV mode the ASR gain is divided into a high-speed and low-speed section. The speed controller has a high-speed gain (20-00 & 20-01) and a low-speed gain (20-02 & 20-03) that can be set independently.

- The high/low switch frequency can be set with parameter 20-15 and 20-16. Similar to the ASR gain, the speed estimator has a high-speed gain (20-09 & 20-10) and a low-speed gain (20-11 & 20-12).
- The speed estimator has a low-pass filter to reduce speed feedback interference. Parameter 20-13 and 20-14 are active at high speed as well as low speed. The switch between high-speed and low-speed is set by parameters 20-15 and 20-16.
- 20-17 sets the low-speed compensation gain of the speed feedback.
- 20-18 sets the high-speed compensation gain of the speed feedback.
- When the frequency reference rises above the value set in 20-16, the ASR gain used is set by parameters 20-00 and 20-01.
- When the frequency reference falls below the value set in 20-15, the ASR gain used is set by parameters 20-02 and 20-03.
- Gain time constant is adjusted linearly when the speed command falls within the range of 20-15 to 20-16, for a smooth operation.



Tuning the speed control gain

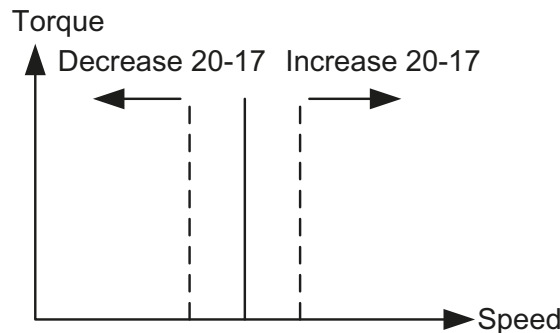
During ASR gain tuning, the multi-function analog output (AO1 terminal) can be used to monitor the output frequency and motor speed (as shown in figure above).

SLV mode gain tuning (20-00 to 20-03, 20-09 to 20-18)

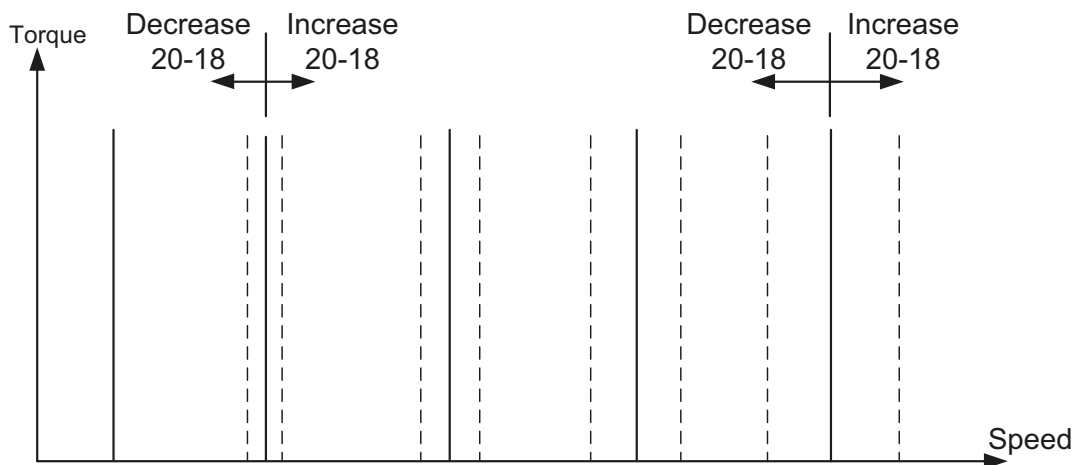
- Tune the low-speed ASR P and I gain (20-02 & 20-03), make sure the reference frequency is set below the value of parameter 20-15.
- Tune the high-speed ASR PI gain 20-00 & 20-01, make sure the reference frequency is above the value set in parameter 20-16 value.
- Both low-speed ASR gain and the high-speed gain can be set to the same values and only require adjustment in case of system instability.
- Reduce the low-pass filter time constant 20-13 & 20-14 to decrease the bandwidth of the feedback system and re-tune the ASR gain, if tuning the ASR P and I gain 20-00 to 20-03 does not improve the system response.
- Tune low-speed low-pass filter time constant 20-14, make sure the reference frequency is below parameter 20-15 value.
- Tune high-speed low-pass filter time constant 20-13 at frequency reference, make sure the reference frequency is above parameter 20-16 value.
- Increasing the low-pass filter time constant can limit the bandwidth of the speed feedback system and may reduce the system response. Increasing the low-pass time reduces the speed feedback signal interference but may result in sluggish system response when the load suddenly changes. Adjust the low-pass filter time if the load stays fairly constant during normal operation. The low speed feedback bandwidth must be supported by the low ASR gain to ensure the stable operation.
- Decreasing the low-pass filter time constant may increase the bandwidth of the speed feedback and the system response. Decreasing the low-pass time may increase the speed feedback interference resulting in system instability when the load suddenly changes. Decreasing the low-pass filter time shortens system response time and is required for rapidly changing loads. The high speed feedback bandwidth allows for a relatively high ASR gain.

- 9) If tuning (20-00 to 20-03) and the low-pass filter time constant (20-13 to 20-14) do not improve system response time, tuning the PI gain (20-09 to 20-12) of the speed estimator may be required.
- 10) Setting a high gain for the speed estimator (high proportion (P) gain and small integral (I) time) increases the bandwidth of the speed feedback, but may cause speed feedback interference resulting in system instability.
- 11) Setting a low gain for the speed estimator (small proportion (P) gain and high integral (I) time) decreases the bandwidth of the speed feedback, may improve speed feedback interference resulting in a more stable system.
- 12) The default values for the ASR can be used in most applications, no adjustment required. Adjusting the low-pass filter time and speed estimator gain requires a good understanding of the overall system. If a high-speed system response in combination with stable operation is required consider using SLV control mode.
- 13) Parameter 20-15 sets the gain switch frequency at low-speed and parameter 20-16 sets the gain switch frequency at high-speed.
- 14) Operating at a speed below 20-15 will result in an increased excitation current for low-speed operation accuracy. When the frequency reference rises above 20-16, the AC Drive will output the rated excitation current at the no-load voltage (02-19).
- 15) For general purpose applications parameter 20-15 should be set to a value of 5–50% of the motor base frequency. If this value is too high, the AC Drive output may saturate. Parameter 20-16 should be set to a value of 4Hz or more above value of 20-08.
- 16) When experiencing speed jitter at high speed and stable operation during mid-range speed while operating a heavy load (>100%), it is recommended to reduce the no-load voltage (02-19) or tune the FOC parameters (18-05 to 18-06).
- 17) Parameters 20-17 and 20-18 are for compensating speed feedback at low speed and high speed.
- 18) Use parameter 20-17 to adjust the torque compensation gain for the low speed range. By tuning 20-17 an offset is added to the torque-speed curve. Increase 20-17 when the no-load speed is lower than the frequency reference. Decrease 20-17 when the no-load speed is higher than the frequency reference.

The effect on the speed-torque curve from 20-17 is shown in the following figure



Use parameter 20-18 to adjust the torque compensation gain for medium to high speed range. For most general purpose applications it is not necessary to adjust the 20-18. The effect on the speed-torque curve by parameter 20-18 is shown in figure below.



20-04: ASR integral limit

Setting the ASR integral limit to a low value may prevent a large system response when the load suddenly changes.

20-08: ASR main delay time

(1) Does not require adjustment for general purpose applications.

(2) When the value of 20-08 is set high, speed response and system response will decrease, and improve system stability.

20-34	Compensation Gain of Derating	Default: 0
Range	【0-25600】	
20-35	Compensation Time of Derating	Default: 100
Range	【-30000】 ms	

This gain effect is the same as ASR proportional gain (20-00 & 20-02). If this parameter is coupled with low-pass filter time constant (20-35), it can avoid oscillation. It is suggested that parameter 20-34 is set between 30 and 50.

This time constant is used for suppressing the oscillation produced by 20-34. If compensation time constant is too large, it will result in a slower output response and then is unfavorable for turned compensation. It is suggested that parameter 20-35 is set between 50-100ms.

Decreasing the torque compensation value can reduce the response of the ASR during a momentary change in load. Refer to parameter details for "SLV Control Mode" and "ASR Setting (SLV/PMSLV Control Mode)".

20-34 Compensation Gain During Speed Drop:

The effect of parameter 20-34 is the same as the proportional gain of the ASR (20-00, 20-02) but active only for the time specified in 20-35 for large speed fluctuation to prevent system instability.

20-35 Compensation Time During Speed Drop:

This parameter sets the time constant used to prevent system instability caused by parameter 20-34. An increased compensation time can lead to a slower output response which can affect derating compensation in a negative way.

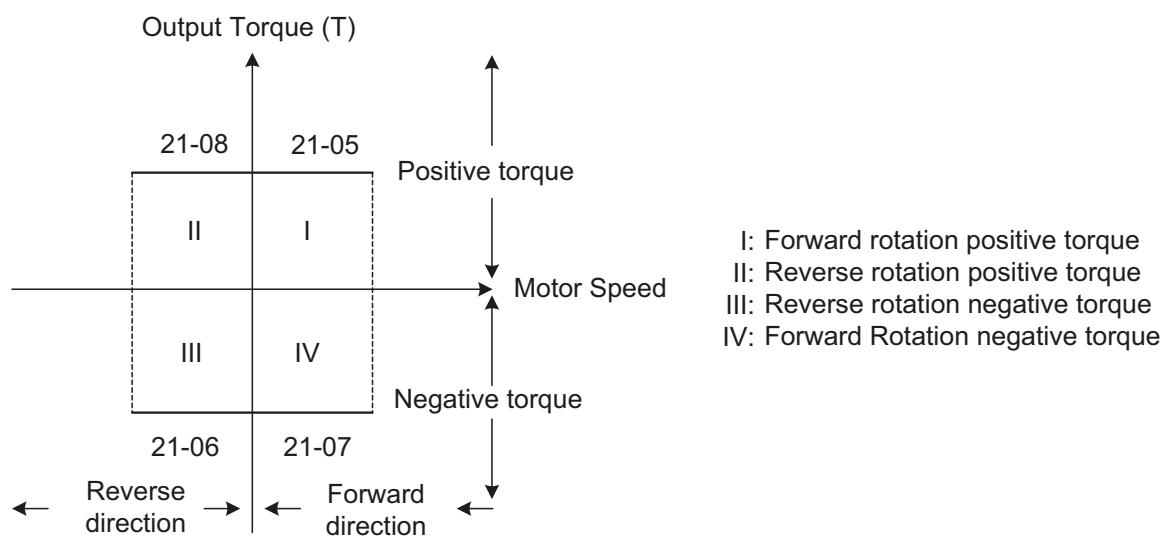
The recommended setting value of 20-34 is between 30-50 and for 20-35 between 50-100ms.

21 Torque Limit Parameters

21-05	Positive Torque Limit	Default: 150
Range	【0-300】 %	
21-06	Negative Torque Limit	Default: 150
Range	【0-300】 %	
21-07	Forward Regenerating Torque Limit	Default: 150
Range	【0-300】 %	
21-08	Reversal Regenerating Torque Limit	Default: 150
Range	【0-300】 %	

SLV and PMSLV control mode offer four torque limits that can be adjusted independently:

- I. Positive torque limit in forward direction (21-05 positive torque limit)
- II. Positive torque limit of reverse direction (21-06 negative torque limit)
- III. Negative torque limit in reverse direction (21-07 forward regenerating torque limit)
- IV. Negative torque limit in forward direction (21-08 reverse regenerating torque limit)



22 PM Motor Parameters

22-00	PM Motor Rated Power	Default: Per Model
Range	【0.00–600.00】 KW	
22-02	PM Motor Rated Current	Default: Per Model
Range	【25%–200%】 of AC Drive's rated current	
22-03	PM Motor's Pole Number	Default: Per Model
Range	【2–96】 Poles	
22-04	PM Motor's Rated Rotation Speed	Default: Per Model
Range	【6–65535】 RPM	
22-05	PM Motor's Maximum Rotation Speed	Default: Per Model
Range	【6–65535】 RPM	
22-06	PM Motor Rated Frequency	Default: Per Model
Range	【4.8–599.0】 Hz	

The PM parameter group can be restored to factory default by initializing the AC Drive (13-08). Set the motor rating before initializing the AC Drive (13-00).

22-00: PM motor rated power

Set the motor power according to the motor nameplate.

22-02: PM motor rated current

Set the motor full load according to the motor nameplate.

22-03: PM motor pole number

Set the number of motor poles according to the motor nameplate.

22-04: PM motor rated speed

Set parameter 22-04 or 22-06, the AC Drive will automatically calculate one or the other. For more details see parameter 22-06.

Set the motor rated speed in RPM according to the motor nameplate.

Note:

Only set parameter 22-04 or 22-06, the AC Drive will automatically calculate the other one.
 Formula (22-04) = 120 x f (22-06) / Number of Poles (22-03)

22-05: PM motor maximum rotation speed

Set the maximum motor rated speed in rpm according to the motor nameplate.

22-06: PM motor rated frequency

Set the motor rated frequency according to the motor nameplate.

Only one of the two values is required, either PM motor rated speed (22-04) or PM motor rated frequency (22-06), the AC Drive will automatically calculate the other upon entering the data based on the formula below:

$$(\text{PM motor rated speed}) N = \frac{120 \times f (\text{PM motor rated frequency})}{P (\text{PM motor pole number})}$$

22-10	PM SLV Start Current	Default: 50
Range	【20.0–120.0】 % (Motor Rated Current)	
22-11	I/F Mode Start Frequency Switching Point	Default: 10
Range	【1.0–20.0】 %	
22-14	Armature Resistance of PM Motor	Default: 1
Range	【0.001–30.000】 Ω	
22-15	D-axis Inductance of PM Motor	Default: 10
Range	【0.01–300.00】 mH	
22-16	Q-axis Inductance of PM Motor	Default: 10
Range	【0.01–300.00】 mH	
22-18	Flux-Weakening Limit	Default: 0
Range	【0–100】 %	
22-21	PM motor tuning	Default: 0
Range	【0】 : PM Motor Tuning is not Active 【1】 : Parameter Auto-tune (for PMSLV Tuning)	
22-22	PM motor tuning fault	Default: 0
Range	【0】 : No Error 【5】 : Loop Adjustment Timed Out 【7】 : Other Motor Tuning Errors 【9】 : Current Abnormal during Loop Adjustment	
22-23	PM SLV acceleration time	Default: 1
Range	【0.1–10.00】 Sec	
22-25	Initial position Detection of PM Motor	Default: 1
Range	【0】 : Disable 【1】 : Detected when AC Drive is running	

22-10: PMSLV Start Current

Set the torque current at start up as % of motor rated current.

22-11: I/F Mode Start Frequency Switching Point

Function for the switching from open-loop to closed-loop in PMSLV mode. The unit is percentage of rated speed of the motor. It recommended to set this parameter to a value greater than 5% for 480V and a value greater than 10% for 240V.

22-14: Armature Resistance of PM Motor

Set resistor for each phase of the motor in increments of 0.001Ω. Value is set automatically during motor tuning (22-21).

22-15: D-axis Inductance of PM Motor

Set motor D-axis inductance in increments of 0.001mH. Value is set automatically during motor tuning (22-21).

22-16: Q-axis Inductance of PM Motor

Set motor's Q-axis inductance in increments of 0.001mH. Value is set automatically during motor tuning (22-21).

22-18: Flux-Weakening Limit

Sets the flux-weakening limit as a percentage of the motor rated current. If the motor maximum rotation speed (22-05) is set to a value greater than the motor rated rotation speed (22-04) the AC Drive will automatically enable flux-weakening control.

22-21: PM Motor Tuning**WARNING!**

Sudden start: The AC Drive and motor may start unexpectedly during Auto-Tuning, which could result in death or serious injury. Make sure the area surrounding the motor and load are clear before proceeding with Auto-Tuning.

WARNING! Electric Shock Hazard

High voltage is applied to the motor when performing an auto-tune, even when the motor is stopped, which could result in death or serious injury. Do not touch the motor before auto-tuning procedure is completed.

WARNING! Holding Brake

Do not perform an auto-tuning procedure when the motor is connected to a brake. This may result in incorrect motor data calculation. Disconnect the motor and the load and confirm that the motor can freely run.

- (1) Set parameter 00-00=5, and select tuning mode with parameter 22-21.
- (2) Next press the enter key to go to the PM motor tuning screen. The keypad will display "IPrdy" (Ready to Tune).
- (3) Press run key to start the PM motor tuning. The keypad will display "IPtun" during auto-tune.
- (4) If the motor tuning is successful, "IPEnd " will be displayed. If auto-tune is aborted using the stop key, the operator displays " IPbrd " (PM motor tuning aborted).

Note:

Once an auto-tune is performed successfully it is not required to perform motor tuning again when powering up the AC Drive.

22-22: PM motor tuning fault

If auto-tuning fails, the keypad will display "AtErr". Parameter 22-22 is a read only parameter that stores the error code from a failed permanent magnet motor auto-tune.

22-23: PM SLV acceleration time

PM SLV acceleration time is the acceleration time used to go from static to I/F Mode Start Frequency Switching Point (22-11).

Note:

In case of an error or vibration in PMSLV mode, increase or decrease acceleration time.

22-25: Initial position detection of PM motor

Use in PMSLV control mode only. When 22-25=1, the AC Drive will automatically detect the initial position of motor rotor while the motor is running to prevent the motor from running in the opposite direction.

When 22-25=0, detection function is disabled, AC Drive will not perform any detection while the motor is running.

5. Built-in PLC Function

The PLC ladder logic can be created and downloaded using the TD-LINK software.

5.1 Basic Commands

Type	General Output	SET Output	RESET Output	PULSE Output	N.O. Contact	N.C. Contact	Range NO / NC
Inputs					I	i	I1-I6 / i1-i6
Outputs	Q	Q	Q	Q	Q	q	Q1-Q2 / q1-q2
Auxiliary command	M	M	M	M	M	m	M1-MF / m1-mF
AC Drive Function Registers							V1-V7
Counter function	C				C	c	C1-C8 / c1-c8
Timer function	T				T	t	T1-T8 / t1-t8
Analog comparison function	G				G	g	G1-G8 / g1-g8
Operation control function	F				F	f	F1-F8 / f1-f8
Summation and subtraction function	AS						AS1-4
Multiplication and division function	MD						MD1-4

AC Drive Function Registers

V1: Set frequency (Hz)

V2: Operation frequency (Hz)

V3: AI1 input value

V4: AI2 input value

V5: Keypad potentiometer Value

V6: Operation current (A)

V7: Torque value (%)

Command	Positive Differential (One-shot)	Negative Differential (One-shot)	Other Command Symbols
Differential Command	D	d	
SET Command			
RESET Command			
P Command			P
Open Circuit		“ “	
Short Circuit		“_”	

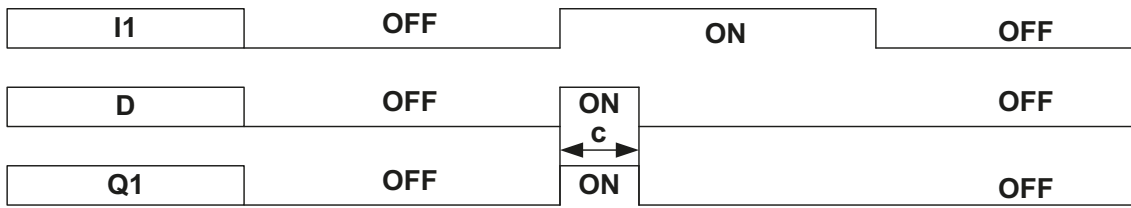
Connection Symbol	Definition
	Connects components on the left and right side
	Connects components on the left, right, and top side
	Connects components on the left, right, top, and bottom side
	Connects components on the left, right, and bottom side

5.1.1 Basic Command Function

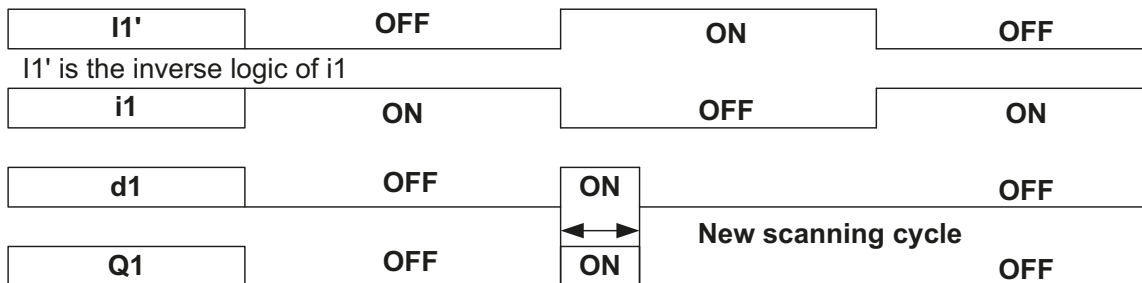
D (d) Positive Differential Function

I1-D —[Q1

C = 1 Scan Cycle

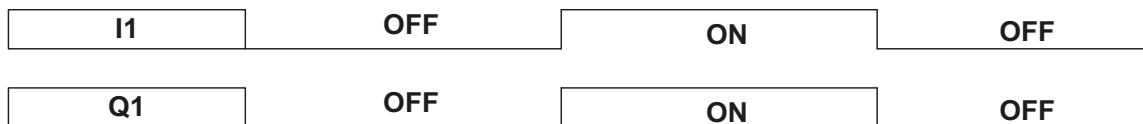


i1-d —[Q1



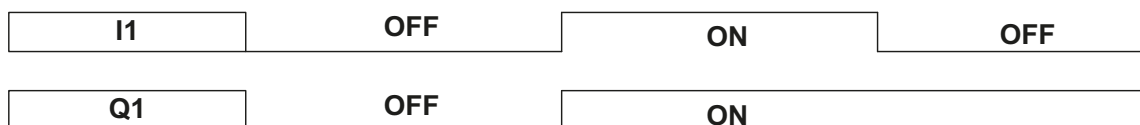
NORMAL(-[) output

I1—[Q1



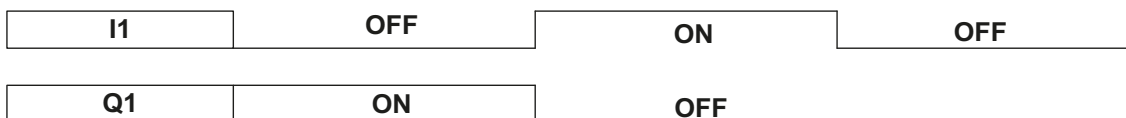
SET (^) output

I1— ^ Q1



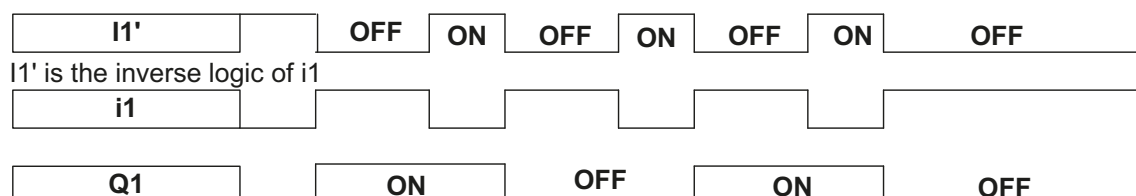
RESET (v) output

I1— v Q1



P output

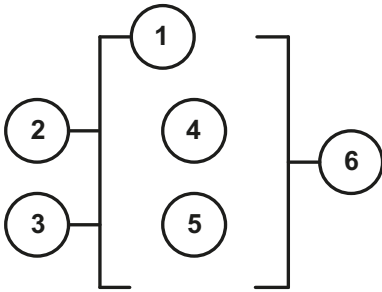
i1—PQ1



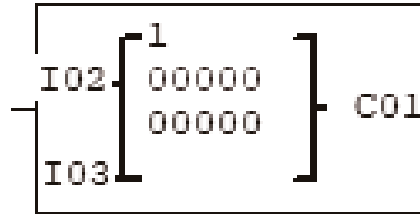
5.2 Application Functions

5.2.1: Counter Function (C)

Function Diagram



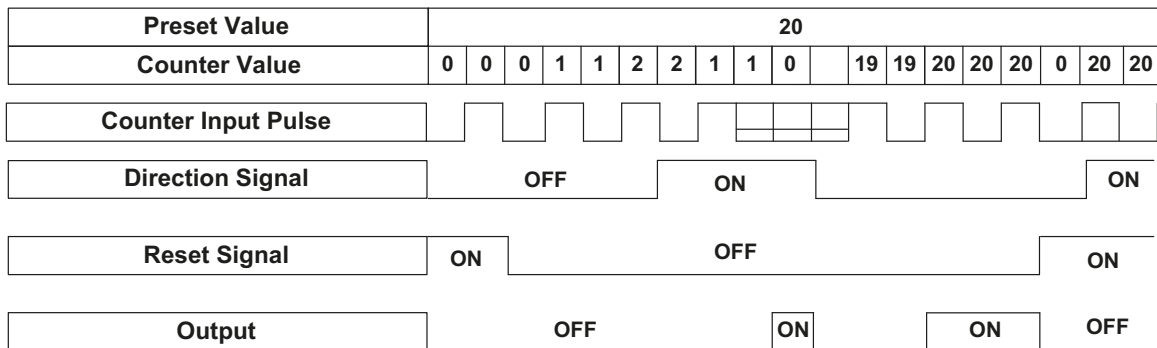
Ladder Display Example



Function Diagram	Ladder Display Example Value	Description
①	1	Counter mode (1 – 4)
②	I02	UP/Down counting modes can be set by (I1 – f8). OFF: Count up (0, 1, 2, 3...) ON: Count down (...3,2,1,0)
③	I03	Use (I1–f8) to reset counting value ON: Internal count value is reset and counter output ⑥ is OFF OFF: Internal counter value retained
④	00000	Counter value
⑤	00000	Counter preset value (AS1–AS4,MD1–MD4,T1–T8,C1–C8,V1–V7,constant)
⑥	C01	Counter output (C1 to C8, there are a total of 8 counters)

Counter Mode 1

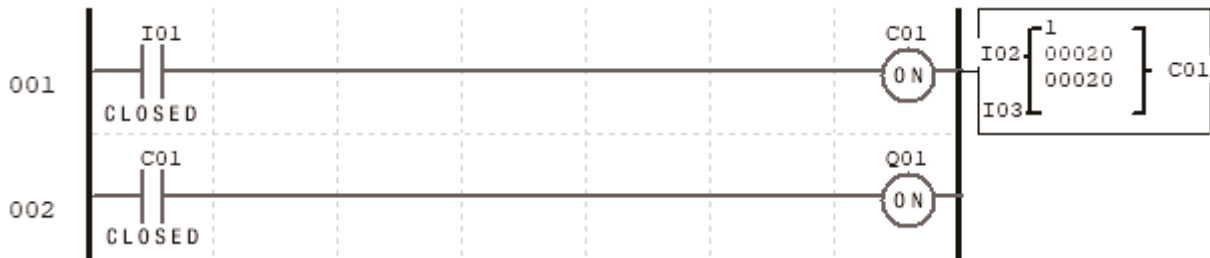
Counter value cannot exceed the set value. Counter value will not be retained when power is cut off.



Each time I01 is activated, the counter value will increase as shown below.

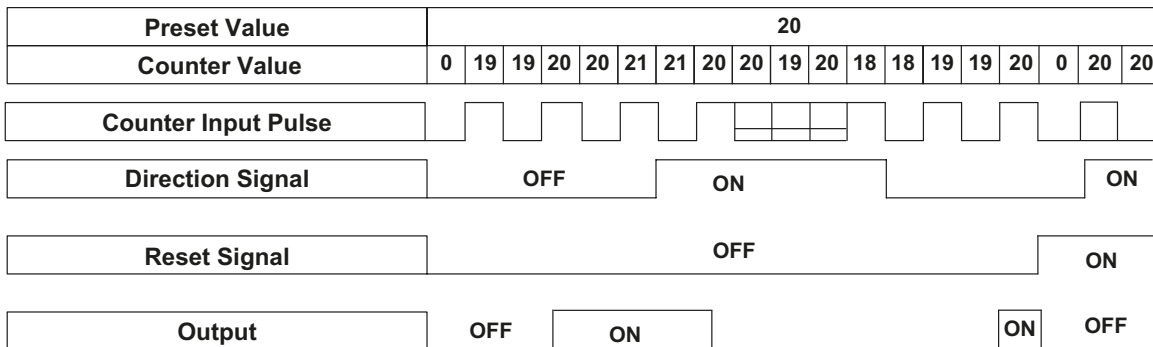


When the counter value reaches the preset value, the counter output (C01) will activate. Correspondingly, any C01 input will also activate. In this manner, a counter output can be used to control another device



Counter Mode 2

Counter value can exceed the set value. Counter value will not be retained when power is cut off.

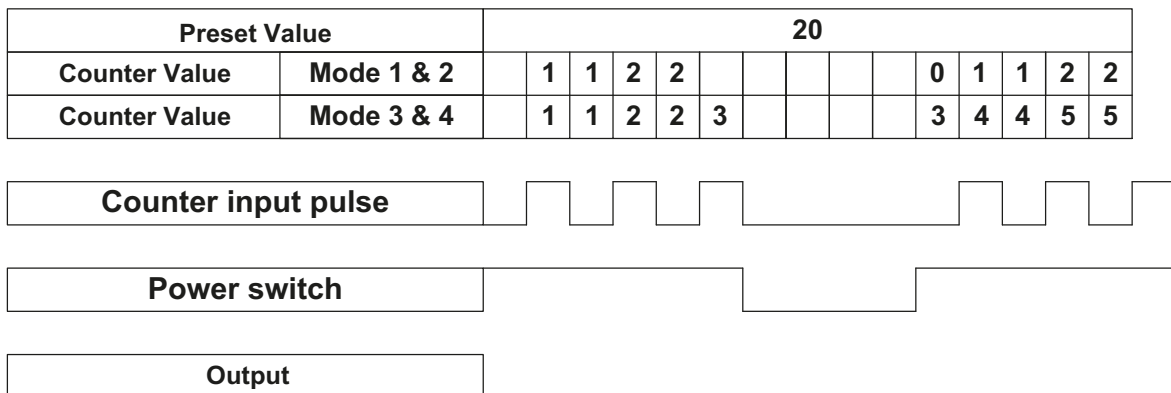


Counter Mode 3

Counter mode 3 is the same function as mode 1 however the counter value will be retained when power is cut off.

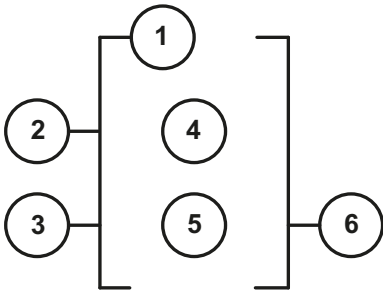
Counter Mode 4

Counter mode 4 is the same function as mode 2 however the counter value will be retained when power is cut off.

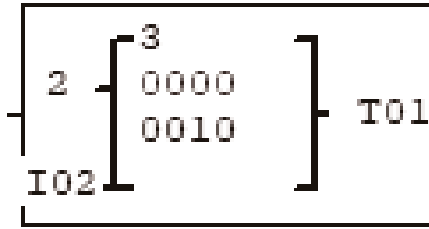


5.2.2: Timer Function (T)

Function Diagram



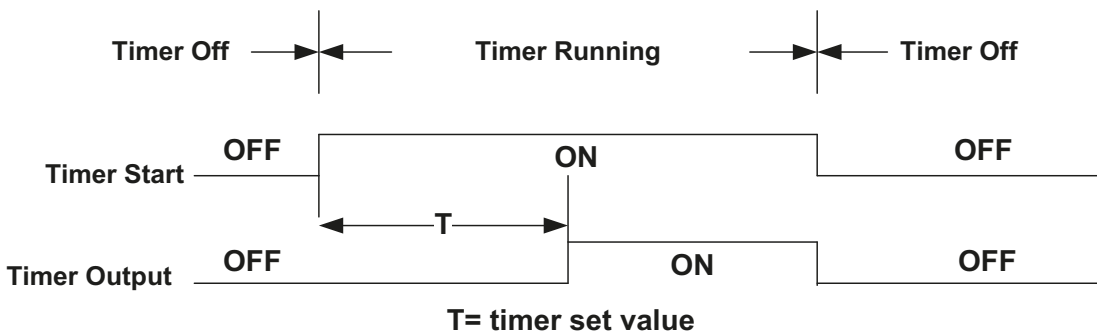
Ladder Display Example



Function Diagram	Ladder Display Example Value	Description
①	3	Timer mode (1-7)
②	2	Timing unit: 1:0.0–999.9 second 2:0–9999 second 3:0–9999 minute
③	I02	Use (I1–f8) to reset timing value ON: Internal timing value is reset and timer output ⑥ is OFF OFF: Internal timer stays running
④	0000	Internal timer value
⑤	0010	Timer set value (AS1–AS4,MD1–MD4,T1–T8,C1–C8,V1–V7,constant)
⑥	T01	Timer output (T1 to T8, there are a total of 8 timers)

Timer Mode 1

ON-delay Timer



While I01 is closed, the timer will start. Timer output (T01) will remain off until the internal timer value reaches the timer set value.

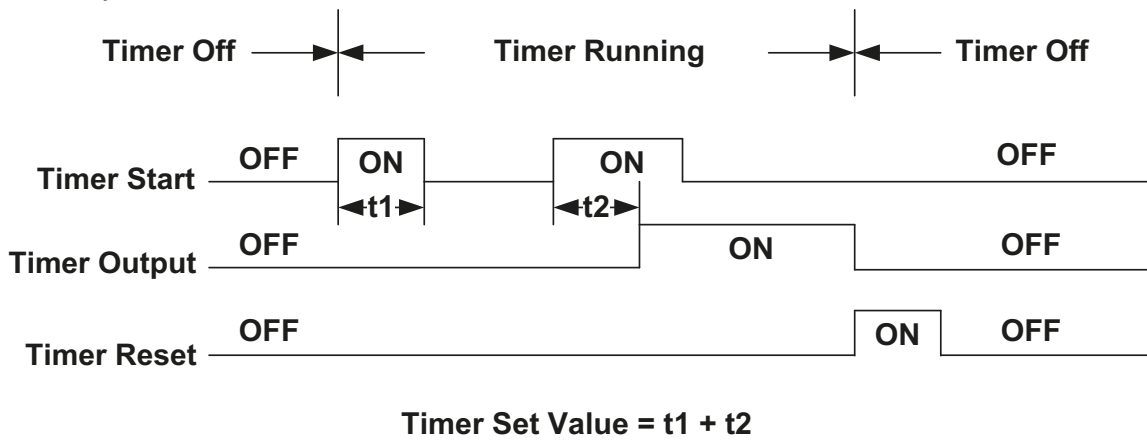


When the internal timer value reaches the timer set value, the timer output (T01) will activate. Correspondingly any T01 input will also activate. In this manner, a timer output can be used to control another device.



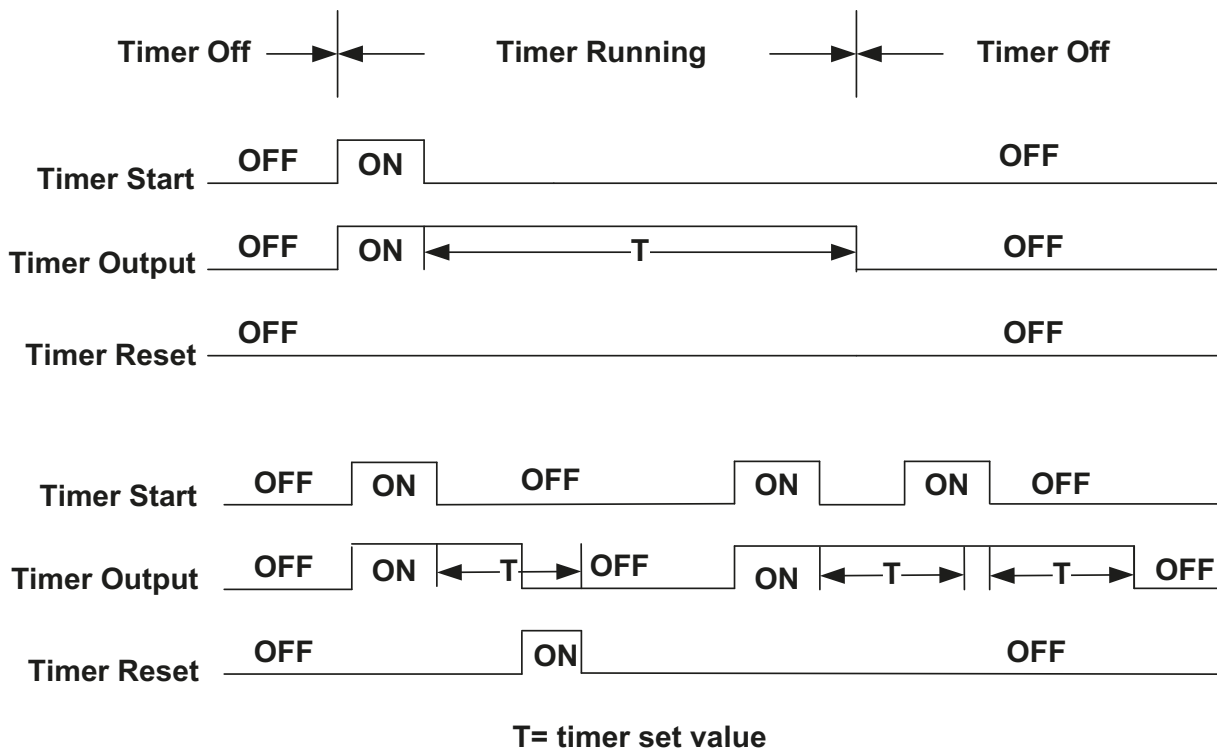
Timer Mode 2

ON-delay Timer Mode 2



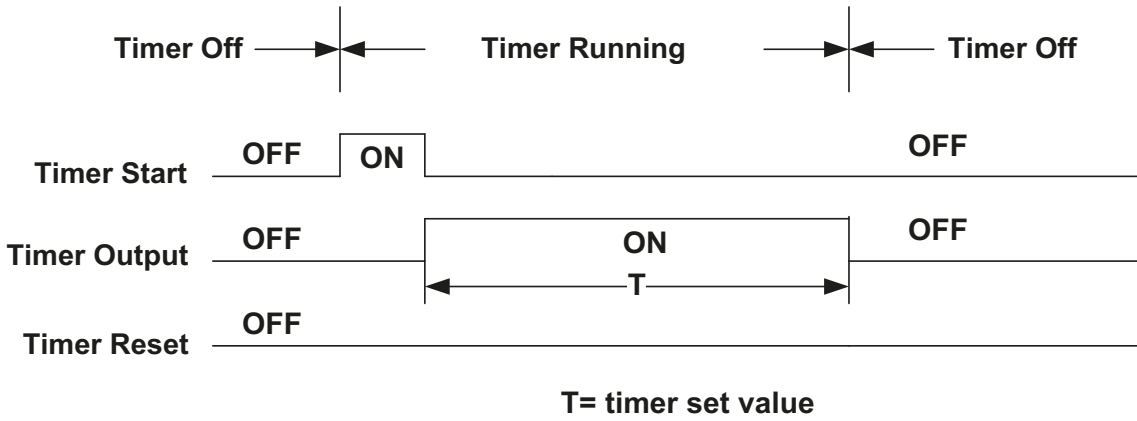
Timer Mode 3

OFF-delay Timer Mode 1



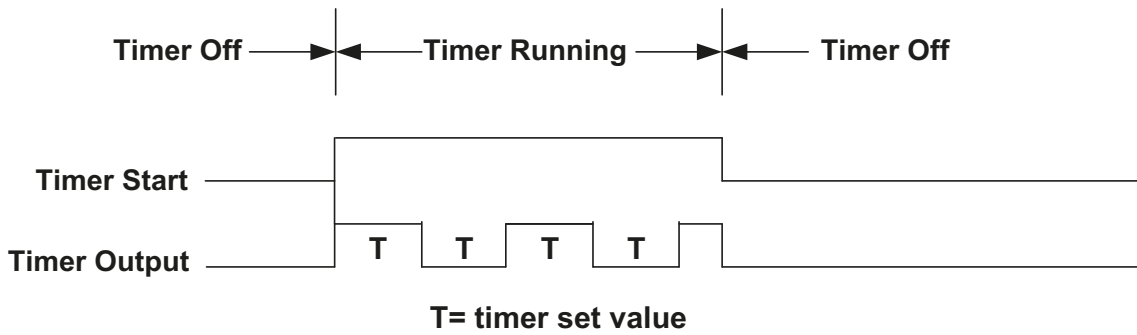
Timer Mode 4

OFF-delay Timer Mode 2



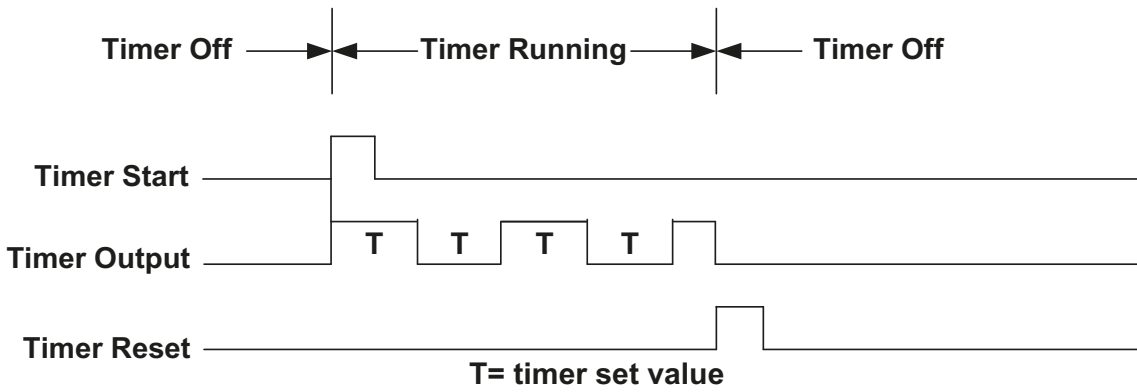
Timer Mode 5

FLASH Timer Mode 1



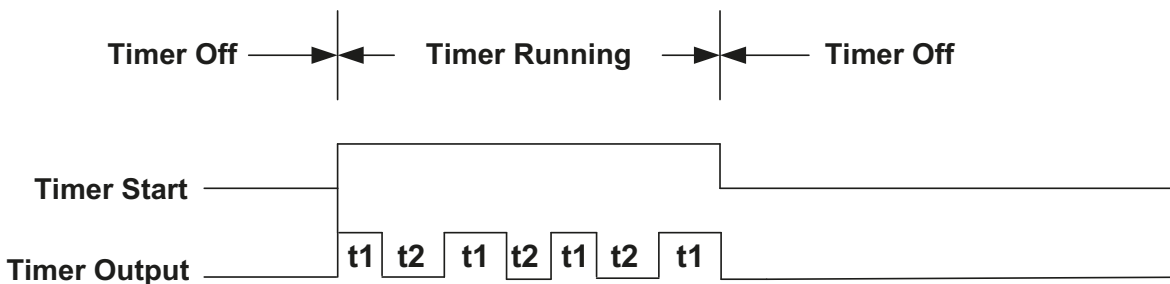
Timer Mode 6

FLASH Timer Mode 2



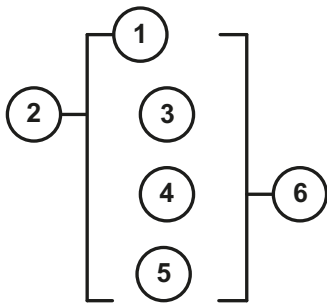
Timer Mode 7

FLASH Timer Mode 3

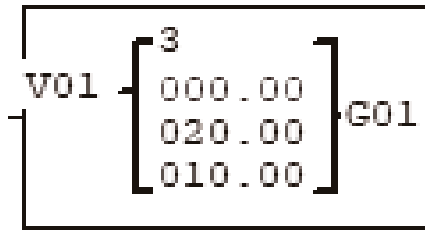


5.2.3: Analog Comparator Function (G)

Function Diagram



Ladder Display Example



Function Diagram	Ladder Display Example Value	Description
①	3	Analog comparator mode (1-3)
②	V01	Analog input selection (AS1-AS4,MD1-MD4,T1-T8,C1-C8,V1-V7)
③	000.00	Analog input value
④	020.00	Upper reference comparison value (AS1-AS4,MD1-MD4,T1-T8,C1-C8,V1-V7, constant)
⑤	010.00	Lower reference comparison value (AS1-AS4,MD1-MD4,T1-T8,C1-C8,V1-V7, constant)
⑥	G01	Comparator output (G1-G8)

Analog Comparator Mode 1

If analog input value ③ is less than or equal to the lower reference comparison value ⑤, then the comparator output ⑥ will be ON

Analog Comparator Mode 2

If analog input value ③ is greater than or equal to the upper reference comparison value ④, then the comparator output ⑥ will be ON

Analog Comparator Mode 3

If analog input value ③ is less than the upper reference comparison value ④ but greater than the lower reference comparison value ⑤, the comparator output ⑥ will be ON.

Analog Input Selection (V1-V7)

V1: Set frequency (Hz)

V2: Operation frequency (Hz)

V3: AI1 input value

V4: AI2 input value

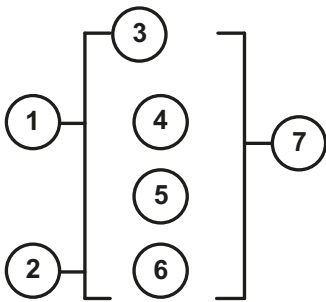
V5: Keypad potentiometer value

V6: Operation current (A)

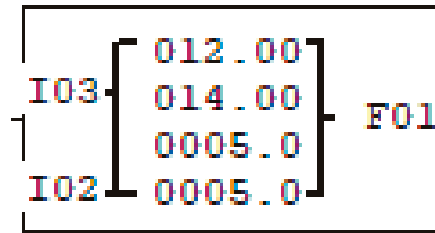
V7: Torque value (%)

5.2.4: Operation Control Function (F)

Function Diagram



Ladder Display Example



Function Diagram	Ladder Display Example Value	Description
①	I03	Forward /Reverse run direction can be controlled by (I1-f8) OFF: Forward (FWD) ON: Reverse (REV)
②	I02	Speed terminal control can be set by (I1-f8) OFF: Operation based on ③ set frequency ON: Operation based on frequency of speed ④
③	012.00	Set frequency (can be constant or V3、 V4、 V5)
④	014.00	Segment frequency (can be constant or V3、 V4、 V5)
⑤	0005.0	Acceleration time (ACC Time)
⑥	0005.0	Deceleration time (DEC Time)
⑦	F01	Operation command output (F1 to F8, there are a total of 8 operation control functions)

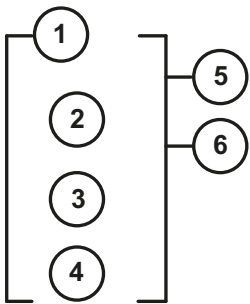
Example:

While I01 is closed, the AC drive will run by default in the forward direction. Input I03 will control the run direction and I02 will select which preset speed to run at.

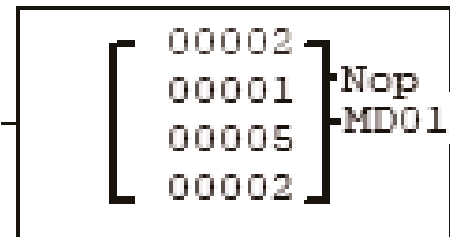
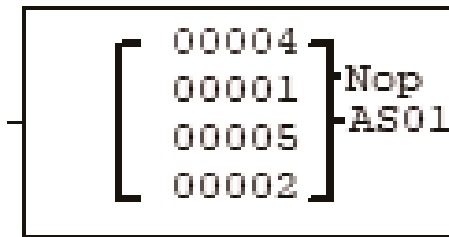


5.2.5: Math Functions (AS / MD)

Function Diagram



Ladder Display Examples



Function Diagram	Ladder Display Example Value	Description
①	00004 00002	Calculation result
②	00001	Base Value V1 (AS1–AS4,MD1–MD4,T1–T8,C1–C8,V1–V7, constant)
③	00005	Addition Value V2 or Multiplication Value V2 (AS1–AS4,MD1–MD4,T1–T8,C1–C8,V1–V7, constant)
④	00003	Subtraction Value V3 or Division Value V3 (AS1–AS4,MD1–MD4,T1–T8,C1–C8,V1–V7, constant)
⑤	NOP	Error Signal Coil Output (M1–MF, NOP=No Error Output)
⑥	AS01 MD01	Addition and subtraction coil (AS1–AS4) Multiply and Divide Coil (MD1–MD4)

Example:

The addition and subtraction function uses this formula in its calculation:

$$V1+V2-V3 = \text{Calculation Result}$$

In the example below, Base Value = 1, Addition Value = 5, and Subtraction Value = 2, resulting in 4 being returned.



Example:

The multiply and divide function uses this formula in its calculation:

$$V1 \times V2 / V3 = \text{Calculation Result}$$

In the example below, Base Value = 1, Multiply Value = 5, and Divide Value = 2, resulting in 2 being returned.

Note: Division function will round the result down to the previous whole number.



6. Communications

The built-in RS-485 can support the following communication protocols:

- Modbus communication protocol
- BACnet communication protocol

The communication port (RJ45 or S+ and S- terminals) can be used to monitor, control, program and trouble-shoot the AC Drive.

Modbus communication can perform the following operations independent of the frequency command (00-05) setting and Operation command (00-02) setting:

- Monitor AC Drive signals
- Read and write parameters.
- Reset fault
- Control multi-function inputs

Items	Specification
Interface	RS-485
Communication type	Asynchronous (start - stop synchronization)
Communication parameters	Baud rate: 4800, 9600, 19200 and 38400 bps Data Length: 7 or 8 bits Parity: options of none, even and odd bit. For even and odd selection stop bit is fixed at 1 bit.
Communication protocol	Modbus RTU / ASCII
Number of AC Drives	Maximum 32 units

Communication wiring and setup

- (1) Turn off power to the AC Drive.
- (2) Connect communication lines of the controller to the AC Drive (RJ45).
- (3) Turn power on.
- (4) Set the required communication parameters (09-00) via the keypad.
- (5) Turn off power to the AC Drive and wait until keypad is completely off.
- (6) Turn power on
- (7) Start communication between controller and AC Drive.

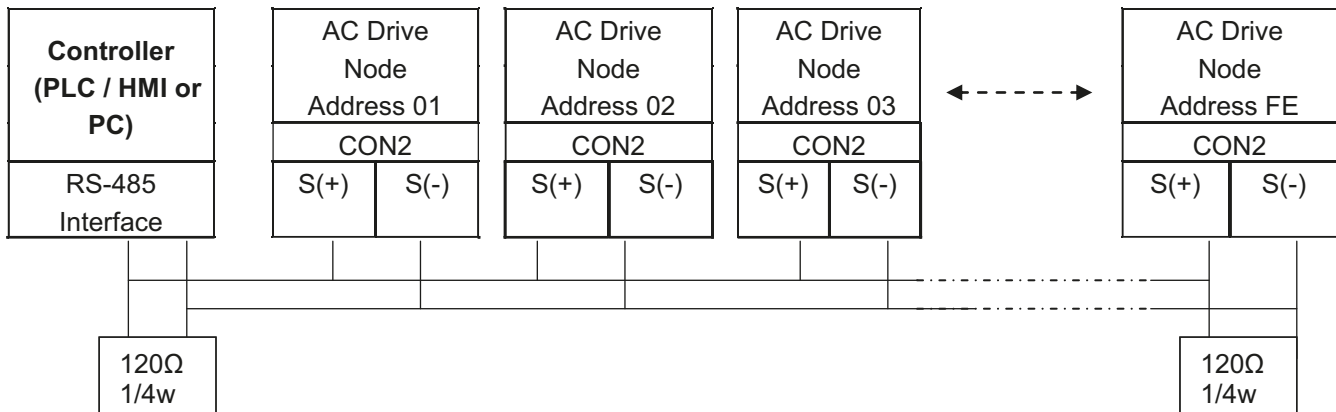
6.1 Modbus Protocol

- (1) The AC Drive can communicate with a PC or PLC via RS485 using the Modbus RTU or Modbus ASCII protocol. The maximum frame length is 80 bytes.
- (2) The master/client controller is directly connected to the AC Drive via the RS-485 interface. If the master/client controller has a RS-232 port, a converter must be used to convert the signals to RS-485.
- (3) A maximum 32 AC Drives can be connected to a network, following the Modbus communication standard.

Note:

Modbus RTU 8 bits data only (09-05).

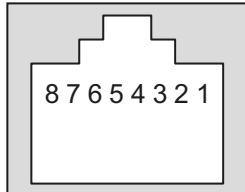
6.1.1 Network Connection



Note:

Terminate the communications line with a 120Ω, 1/4 watt resistor at both ends.

CON2 Pin out



PIN	Signal	PIN	Signal
1	RS-485 S+ signal	5	Tx signal
2	RS-485 S- signal	6	RS-485 S- signal
3	RS-485 S+ signal	7	VCC of isolated 5V supply
4	Rx signal	8	GND of isolated 5V supply

Note:

For RS-485 communication use PIN 1 or PIN 3 for S (+) and PIN 2 or PIN 6 for S (-).

6.1.2 Data Format Frame for ASCII Mode

STX(3AH)	Start Bit = 3AH
Node Address Hi	Communication Address(Station): 2-digit ASCII Code
Node Address Lo	
Function Hi	Function Code (command): 2-digit ASCII Code
Function Lo	
Command Start Address	Command Start byte: 4-digit ASCII Code
Command Start Address	
Command Start Address	
Command Start Address	
Data length	The length of the command: 4-digit ASCII Code
Data length	
Data length	
Data length	
LRC Check Hi	LRC Check Code: 2-digit ASCII Code
LRC Check Lo	
END Hi	End Byte: END Hi=CR(0DH), END Li = LF(0AH)
END Lo	

6.1.3 Data Frame for RTU Mode

Master/Client (PLC etc.) sends request to Slave/Server (AC Drive), and the slave/server sends a response to the master/client (PC, PLC). The data received is illustrated here.

Node Address
Function Code
DATA
CRC CHECK
Signal Interval

The data length varies depending on the command (Function).

Note:

The AC Drive response time is 10ms

Node Address

00H: Broadcast to all the drivers
 01H: to the No. 01 AC Drive
 0FH: to the No.15 AC Drive
 10H: to the No.16 AC Drive and so on....., max to No. 254 (FEH)

Function Code

03H: Read the register contents
 06H: Write a WORD to register
 08H: Loop test
 10H: Write several data to register (complex number register write)

Checksum Calculation

LRC

ex. NODE ADDRESS	01H
FUNCTION	03H
COMMAND	01H
	00H
+ DATA LENGTH	0AH

Checksum	0FH ----- 2's complement
CS (H)	F1H
CS (L) =	46H (ASCII)
	31H (ASCII)

6.1.4 CRC

CRC Check: CRC code covers the content from node address to DATA. Please calculate it according to the following methods.

- (1) Load a 16-bit register with FFFF hex (all 1's). Call this CRC register.
- (2) Exclusive OR the first 8-bit byte of the message, the low-order byte of the 16-bit CRC register, putting the result in the CRC register.
- (3) Shift the CRC register one bit to the right (toward the LSB), Zero-filling the MSB. Extract and examine the LSB.
- (4) (If the LSB was 0): Repeat Steps (3) (another shift)
(If the LSB was 1): Exclusive OR the CRC register with the polynomial value A001 hex (1010 0000 0000 0001), putting the result in CRC register.
- (5) Repeat Steps (3) and (4) until 8 shifts been performed. When this is done, a complete 8-bit byte will be processed.
- (6) Repeat Steps (2) through (5) for next 8-bit byte of the message, Continue doing this until all bytes have been processed. The final content in the CRC register is the CRC value. When sending the CRC value, the Low-order byte should be sent first, then the High-order byte. For example, CRC value: 1241 Hex, the high-order byte should be set to 41hex and low-order byte 12hex.

CRC calculate program (C language):

```

UWORD ch_sum ( UBYTE long , UBYTE *rxdbuff )
{
    BYTE i = 0;
    UWORD wkg = 0xFFFF;
    while ( long-- ) {
        wkg ^= rxdbuff++;
        for ( i = 0 ; i < 8; i++ ) {
            if ( wkg & 0x0001 ) {
                wkg = ( wkg >> 1 ) ^ 0xa001;
            }
            else {
                wkg = wkg >> 1;
            }
        }
    }
    return( wkg );
}

```

ASCII Mode	
STX	':'
	'0'
Address	'1'
	'8'
Function	'6'
Exception code	'5'
	'1'
	'2'
LRC Check	'8'
	'CR'
END	'LF'

RTU Mode		
Node Address		02H
Function		83H
Exception code		52H
CRC-16	High	C0H
	Low	CDH

During a communication error the drive will respond with an Exception Code and send a message back to the main system consisting of a Function Code that is "ANDED (and 80h)" with 80 Hex.

Exception code	Content
1	Function code error
2	Register number error
3	Number error
4	DATA setting error
5	Write mode error

6.1.5 Register and Data Format

Data registers are presented as hex addresses with corresponding 6-digit Modbus addresses in parenthesis.

Command Data (Read / Write)

Register No.		Bit	Content
2500H (409473)	Reserved		
2501H (409474)	Operation Signal	0	Operation Command 1 : Run 0 : Stop
		1	Reverse Command 1 : Reverse 0 : Forward
		2	External Fault 1 : Fault
		3	Fault Reset 1 : Reset
		4	Reserved
		5	Reserved
		6	Multi-function Comm S1 1 :“ON”
		7	Multi-function Comm S2 1 :“ON”
		8	Multi-function Comm S3 1 :“ON”
		9	Multi-function Comm S4 1 :“ON”
		A	Multi-function Comm S5 1 :“ON”
		B	Multi-function Comm S6 1 :“ON”
		C	Reserved
		D	Reserved
		E	AC Drive Mode 1 :“ON”
		F	Torque Command set by Communication 1 :“ON”
2502H (409475)	*Frequency Command (Unit: 0.01Hz)		
2503H (409476)	Torque Command (+/-8192 corresponding to the rated torque +/-100%)		
2504H (409477)	Speed limit (+/- 120 corresponding +/-120%)		
2505H (409478)	AO1 (0.00V – 10.00V)		
2506H (409479)	Reserved		
2507H (409480)	DO		
2508H (409481)	Reserved		
2509H (409482)	Reserved		
250AH (409483)	Reserved		
250BH (409484)	Reserved		
250CH (409485)	Reserved		
250DH (409486)	Reserved		
250EH (409487)	Reserved		
250FH (409488)	Reserved		
2510H (409489)	G12-00 H-WORD		
2511H (409490)	G12-00 L-WORD		

Note:

Write a zero into the register for an unused bit; do not write data to a reserved register.

6.1.6 Monitor Data (Read-only)

Register No.		Bit	Content
2520H (409505)	State Signal	0	Operation 1 : Run 0 : Stop
		1	Direction 1 : Reverse 0 : Forward
		2	AC Drive ready 1 : ready 0 : Nor ready
		3	Fault 1 : Fault active
		4	Warning 1 : "ON"
		5	Zero Speed 1 : "ON"
		6	Is440V 1 : "ON"
		7	Frequency Agree 1 : "ON"
		8	Set Frequency Agree 1 : "ON"
		9	Frequency Detection 1 1 : "ON"
		A	Frequency Detection 2 1 : "ON"
		B	Under Voltage 1 : "ON"
		C	Baseblock 1 : "ON"
		D	Freq Ref. not from Comm. 1 : "ON"
		E	Seq. not from Comm. 1 : "ON"
		F	Over Torque 1 : "ON"

Register No.		Value	Content	Value	Content
2521H (409506)	Error Description	0	Reserved	31	Reserved
		1	UV	32	Reserved
		2	OC	33	Reserved
		3	OV	34	Reserved
		4	OH1	35	Reserved
		5	OL1	36	Reserved
		6	OL2	37	LSCFT(Rtry)
		7	OT	38	CF07
		8	UT	39	Reserved
		9	SC	40	Reserved
		10	Ground OC	41	OLDOP
		11	Reserved	42	Reserved
		12	Input Phase Loss	43	Reserved
		13	Output Phase Loss	44	FBLSS
		14	Reserved	45	Reserved
		15	Reserved	46	OH4
		16	Reserved	47	SS1
		17	External Fault 01	48	CF20
		18	External Fault 02	49	MtrSw (DI Motor Switch Fault)
		19	External Fault 03	50	OC_A
		20	External Fault 04	51	OC_D
		21	External Fault 05	52	OC_C
		22	External Fault 06	53	UD_C
		23	Reserved	54	CF_08
		24	Reserved	55	STO2
		25	PID Feedback Error	56	STO3

Register No.		Value	Content	Value	Content
2521H (409506)	Error Description	26	Keypad Removed	57	PO
		27	Reserved	58	Reserved
		28	CE	59	Reserved
		29	STO1	60	Reserved
		30	Over Torque 2	61	Reserved

Register No.		Bit	Content
2522H (409507)	DI State	0	Multi-function Comm S1 1 :“ON”
		1	Multi-function Comm S2 1 :“ON”
		2	Multi-function Comm S3 1 :“ON”
		3	Multi-function Comm S4 1 :“ON”
		4	Multi-function Comm S5 1 :“ON”
		5	Multi-function Comm S6 1 :“ON”
		6	Reserved
		7	Reserved
		8	Reserved
		9	Reserved
		A	Reserved
		B	Reserved
		C	Reserved
		D	Reserved
		E	Reserved
		F	Reserved
2523H (409508)		Frequency command (0.01Hz)	
2524H (409509)		Output frequency (0.01Hz)	
2525H (409510)		Reserved	
2526H (409511)		DC voltage command (0.1V)	
2527H (409512)		Output current (0.1A)	

Register No.	Value	Content	Value	Content	Value	Content	Value
2528H (409513)	0	No alarm	20	EF4	40	EF	60
	1	OV	21	EF5	41	Reserved	61
	2	UV	22	EF6	42	Reserved	62
	3	OL2	23	EF7	43	RDP	63
	4	OH2	24	EF8	44	Reserved	64
	5	Reserved	25	Reserved	45	OL1	65
	6	OT	26	CLB	46	HP_ER	66
	7	Reserved	27	Reserved	47	SE10	67
	8	Reserved	28	CT	48	Reserved	68
	9	UT	29	USP	49	BB1	69
	10	OS	30	RDE	50	BB2	70
	11	PGO	31	WRE	51	BB3	71
	12	DEV	32	FB	52	BB4	72
	13	CE	33	VRYE	53	BB5	73
	14	CALL	34	SE01	54	BB6	74
	15	Reserved	35	SE02	55	BB7	75

Register No.	Value	Content	Value	Content	Value	Content	Value
2528H (409513)	16	EF0	36	SE03	56	BB8	76
	17	EF1	37	Reserved	57	Reserved	
	18	EF2	38	SE05	58	Reserved	
	19	EF3	39	HPERR	59	Reserved	
2529H (409514)	Digital Output State						
252AH (409515)	AO1 (0.00V – 10.00V)						
252BH (406516)	Reserved						
252CH (409517)	AI 1 Input (0.1%)						
252DH (409518)	AI 2 Input (0.1%)						
252EH (409519)	Reserved						
252FH (409520)	L510(s)/ E510(s)/ A510(s)/ F510 Check						

Note:

Write a zero into the register for an unused bit; do not write data to a reserved register.

6.1.7 Read holding Register [03H]

Read consecutive holding registers. The address of the first holding register is specified in the protocol

Example: Read frequency command from the AC Drive with node address 1.

ASCII Mode

Command Message

3AH	STX
30H	Node Address
31H	
30H	Function
33H	
30H	Starting Register
31H	
32H	
33H	
30H	Number of Registers
30H	
30H	
31H	
?	LRC CHECK
?	
0DH	END
0AH	

Response Message (Norm.)

3AH	STX
30H	Node Address
31H	
30H	Function
33H	
30H	Data Length
32H	
31H	Data
37H	
37H	
30H	
?	LRC CHECK
?	
0DH	END
0AH	

Response Message (Error)

3AH	STX
30H	Node Address
32H	
38H	Function
33H	
35H	Exception code
32H	
?	LRC CHECK
?	
0DH	END
0AH	

RTU Mode

Command Message

Node Address		01 H
Function		03H
Starting Register	High	01H
	Low	23H
Number of Registers	High	00H
	Low	01H
CRC-16	High	74H
	Low	3CH

Response Message (Norm.)

Node Address		01H
Function		03H
Data Length		02H
Data	High	17H
	Low	70H
CRC-16	High	AFH
	Low	82H

Response Message (Error)

Node Address		02H
Function		83H
Exception code		52H
CRC-16	High	C0H
	Low	CDH

6.1.8 Loop Back Test [08H]

Check the communication between the master/client and the slave/server (AC Drive). The data used can be arbitrary.

ASCII Mode

Command Message

3AH	STX
30H	Node Address
31H	
30H	Function
38H	
30H	Test Code
30H	
30H	
30H	
30H	
41H	DATA
35H	
33H	
37H	
?	LRC CHECK
?	
0DH	END
0AH	

Response Message (Norm.)

3AH	STX
30H	Node Address
31H	
30H	Function
38H	
30H	Test Code
30H	
30H	
30H	
30H	
41H	DATA
35H	
33H	
37H	
?	LRC CHECK
?	
0DH	END
0AH	

Response Message (Error)

3AH	STX
30H	Node Address
31H	
38H	Function
38H	
32H	Exception code
30H	
?	LRC CHECK
?	
0DH	END
0AH	

RTU Mode

Command Message

Node Address		01 H
Function		08H
Test Code	High	00H
	Low	00H
DATA	High	A5H
	Low	37H
CRC-16	High	DAH
	Low	8DH

Response Message (Norm.)

Node Address		01H
Function		08H
Test Code	High	00H
	Low	00H
DATA	High	A5H
	Low	37H
CRC-16	High	DAH
	Low	8DH

Response Message (Error)

Node Address		01H
Function		88H
Exception code		20H
CRC-16	High	47H
	Low	D8H

6.1.9 Write Single Holding Register [06H]

Write single holding register. The register address of the holding register is specified in the message.

Example: Write a 60.00Hz frequency command to node address 1.

ASCII Mode

Command Message

3AH	STX
30H	Node Address
31H	
30H	Function
36H	
30H	Starting Register
31H	
30H	
32H	
31H	DATA
37H	
37H	
30H	
?	
?	LRC CHECK
0DH	END
0AH	

Response Message (Norm.)

3AH	STX
30H	Node Address
31H	
30H	Function
36H	
30H	Starting Register
31H	
30H	
32H	
31H	DATA
37H	
37H	
30H	
?	
?	LRC CHECK
0DH	END
0AH	

Response Message (Error)

3AH	STX
30H	Node Address
31H	
38H	Function
36H	
35H	Exception code
32H	
?	LRC CHECK
?	
0DH	END
0AH	

RTU Mode

Command Message

Node Address		01 H
Function		06H
Start No	High	01H
	Low	02H
DATA	High	17H
	Low	70H
CRC-16	High	27H
	Low	E2H

Response Message (Norm.)

Node Address		01H
Function		06H
Start No	High	01H
	Low	02H
DATA	High	17H
	Low	70H
CRC-16	High	27H
	Low	E2H

Response Message (Error)

Node Address		01H
Function		86H
Exception code		52H
CRC-16	High	C3H
	Low	9DH

6.1.10 Write Multiple Holding Register [10H]

Write multiple holding register. The register address of the first holding register is specified in the message.

Example: Write a 60.00Hz frequency command to node address 1 and enable FWD run command.

ASCII Mode

Command Message

3AH	STX
30H	Node Address
31H	
31H	Function
30H	
30H	Starting Register
31H	
30H	
31H	
30H	Number of Registers
30H	
32H	
30H	Number of Bytes*
34H	
30H	DATA 1
30H	
30H	
31H	
31H	DATA 2
37H	
37H	
30H	
?	LRC CHECK
?	
0DH	END
0AH	

Note:

Number of bytes is register amount x 2

Response Message (Norm.)

3AH	STX
30H	Node Address
31H	
31H	Function
30H	
30H	Starting Register
31H	
30H	
31H	
30H	Number of Registers
30H	
32H	
?	LRC CHECK
?	
0DH	END
0AH	

Response Message (Error)

3AH	STX
30H	Node Address
31H	
39H	Function
30H	
35H	Exception code
32H	
?	LRC CHECK
?	
0DH	END
0AH	

RTU Mode

Command Message

Node Address		01H
Function		10H
Starting Register	High	01H
	Low	01H
Number of Registers	High	00H
	Low	02H
Number of Bytes*		04H
DATA 1	High	00H
	Low	01H
DATA 2	High	17H
	Low	70H
CRC-16	High	60H
	Low	27H

Note:

Number of bytes is register amount x 2

Response Message (Norm.)

Node Address		01H
Function		10H
Starting Register	High	01H
	Low	01H
Number of Registers	High	00H
	Low	02H
CRC-16	High	11H
	Low	F4H

Response Message (Error)

Node Address		01H
Function		90H
Exception code		52H
CRC-16	High	CDH
	Low	FDH

6.1.11 Modbus Addressing

Function	Register No	Function	Register No	Function	Register No
Group 0		Group 1		Group 2	
0 – 00	0000H (400001)	1 – 00	0100H (400257)	2 – 00	0200H (400513)
0 – 01	0001H (400002)	1 – 01	0101H (400258)	2 – 01	0201H (400514)
0 – 02	0002H (400003)	1 – 02	0102H (400259)	2 – 02	0202H (400515)
0 – 03	0003H (400004)	1 – 03	0103H (400260)	2 – 03	0203H (400516)
0 – 04	0004H (400005)	1 – 04	0104H (400261)	2 – 04	0204H (400517)
0 – 05	0005H (400006)	1 – 05	0105H (400262)	2 – 05	0205H (400518)
0 – 06	0006H (400007)	1 – 06	0106H (400263)	2 – 06	0206H (400519)
0 – 07	0007H (400008)	1 – 07	0107H (400264)	2 – 07	0207H (400520)
0 – 08	0008H (400009)	1 – 08	0108H (400265)	2 – 09	0209H (400522)
0 – 09	0009H (400010)	1 – 09	0109H (400266)	2 – 10	020AH (400523)
0 – 10	000AH (400011)	1 – 10	010AH (400267)	2 – 11	020BH (400524)
0 – 11	000BH (400012)	1 – 11	010BH (400268)	2 – 12	020CH (400525)
0 – 12	000CH (400013)	1 – 12	010CH (400269)	2 – 13	020DH (400526)
0 – 13	000DH (400014)	1 – 13	010DH (400270)	2 – 15	020FH (400528)
0 – 14	000EH (400015)	1 – 14	010EH (400271)	2 – 17	0211H (400530)
0 – 15	000FH (400016)	1 – 15	010FH (400272)	2 – 19	0213H (400532)
0 – 16	0010H (400017)	1 – 16	0110H (400273)	2 – 20	0214H (400533)
0 – 17	0011H (400018)	1 – 17	0111H (400274)	2 – 21	0215H (400534)
0 – 18	0012H (400019)	1 – 18	0112H (400275)	2 – 22	0216H (400535)
0 – 19	0013H (400020)	1 – 19	0113H (400276)	2 – 23	0217H (400536)
0 – 20	0014H (400021)	1 – 20	0114H (400277)	2 – 24	0218H (400537)
0 – 21	0015H (400022)	1 – 21	0115H (400278)	2 – 25	0219H (400538)
0 – 22	0016H (400023)	1 – 22	0116H (400279)	2 – 26	021AH (400539)
0 – 23	0017H (400024)	1 – 23	0117H (400280)	2 – 32	0220H (400545)
0 – 24	0018H (400025)	1 – 24	0118H (400281)	2 – 33	0221H (400546)
0 – 26	001AH (400027)	1 – 25	0119H (400282)	2 – 34	0222H (400547)
0 – 27	001BH (400028)	1 – 26	011AH (400283)		
0 – 34	0022H (400035)				
0 – 35	0023H (400036)				
0 – 36	0024H (400037)				

Function	Register No	Function	Register No	Function	Register No
Group 5		Group 6		Group 6	
5 – 33	0521H (401314)	6 – 00	0600H (401537)	6 – 41	0629H (401578)
5 – 34	0522H (401315)	6 – 01	0601H (401538)	6 – 42	062AH (401579)
5 – 35	0523H (401316)	6 – 02	0602H (401539)	6 – 43	062BH (401580)
5 – 36	0524H (401317)	6 – 03	0603H (401540)	6 – 44	062CH (401581)
5 – 37	0525H (401318)	6 – 04	0604H (401541)	6 – 45	062DH (401582)
5 – 38	0526H (401319)	6 – 05	0605H (401542)	6 – 46	062EH (401583)
5 – 39	0527H (401320)	6 – 06	0606H (401543)	6 – 47	062FH (401584)
5 – 40	0528H (401321)	6 – 07	0607H (401544)		
5 – 41	0529H (401322)	6 – 08	0608H (401545)		
5 – 42	052AH (401323)	6 – 09	0609H (401546)		
5 – 43	052BH (401324)	6 – 10	060AH (401547)		
5 – 44	052CH (401325)	6 – 11	060BH (401548)		
5 – 45	052DH (401326)	6 – 12	060CH (401549)		
5 – 46	052EH (401327)	6 – 13	060DH (401550)		
5 – 47	052FH (401328)	6 – 14	060EH (401551)		
5 – 48	0530H (401329)	6 – 15	060FH (401552)		
		6 – 16	0610H (401553)		
		6 – 17	0611H (401554)		
		6 – 18	0612H (401555)		
		6 – 19	0613H (401556)		
		6 – 20	0614H (401557)		
		6 – 21	0615H (401558)		
		6 – 22	0616H (401559)		
		6 – 23	0617H (401560)		
		6 – 24	0618H (401561)		
		6 – 25	0619H (401562)		
		6 – 26	061AH (401563)		
		6 – 27	061BH (401564)		
		6 – 28	061CH (401565)		
		6 – 29	061DH (401566)		
		6 – 30	061EH (401567)		
		6 – 31	061FH (401568)		
		6 – 32	0620H (401569)		
		6 – 33	0621H (401570)		
		6 – 34	0622H (401571)		
		6 – 35	0623H (401572)		
		6 – 36	0624H (401573)		
		6 – 37	0625H (401574)		
		6 – 38	0626H (401575)		
		6 – 39	0627H (401576)		
		6 – 40	0628H (401577)		

Function	Register No	Function	Register No	Function	Register No
Group 7		Group 8		Group 9	
7 – 00	0700H (401793)	8 – 00	0800H (402049)	9 – 00	0900H (402305)
7 – 01	0701H (401794)	8 – 01	0801H (402050)	9 – 01	0901H (402306)
7 – 02	0702H (401795)	8 – 02	0802H (402051)	9 – 02	0902H (402307)
7 – 03	0703H (401796)	8 – 03	0803H (402052)	9 – 03	0903H (402308)
7 – 04	0704H (401797)	8 – 05	0805H (402054)	9 – 04	0904H (402309)
7 – 05	0705H (401798)	8 – 06	0806H (402055)	9 – 05	0905H (402310)
7 – 06	0706H (401799)	8 – 07	0807H (402056)	9 – 06	0906H (402311)
7 – 07	0707H (401800)	8 – 08	0808H (402057)	9 – 07	0907H (402312)
7 – 08	0708H (401801)	8 – 09	0809H (402058)	9 – 08	0908H (402313)
7 – 09	0709H (401802)	8 – 10	080AH (402059)	9 – 09	0909H (402314)
7 – 10	070AH (401803)	8 – 13	080DH (402062)	9 – 10	090AH (402315)
7 – 11	070BH (401804)	8 – 14	080EH (402063)		
7 – 13	070DH (401806)	8 – 15	080FH (402064)		
7 – 15	070FH (401808)	8 – 16	0810H (402065)		
7 – 18	0712H (401811)	8 – 21	0815H (402070)		
7 – 19	0713H (401812)	8 – 22	0816H (402071)		
7 – 20	0714H (401813)	8 – 23	0817H (402072)		
7 – 21	0715H (401814)	8 – 24	0818H (402073)		
7 – 22	0716H (401815)	8 – 25	0819H (402074)		
7 – 23	0717H (401816)	8 – 35	0823H (402084)		
7 – 24	0718H (401817)	8 – 36	0824H (402085)		
7 – 25	0719H (401818)	8 – 38	0826H (402087)		
7 – 26	071AH (401819)	8 – 39	0827H (402088)		
7 – 27	071BH (401820)	8 – 40	0828H (402089)		
7 – 28	071CH (401821)	8 – 41	0829H (402090)		
7 – 29	071DH (401822)	8 – 42	082AH (402091)		
7 – 33	0721H (401826)	8 – 43	082BH (402092)		
7 – 34	0722H (401827)	8 – 44	082CH (402093)		
7 – 35	0723H (401828)	8 – 46	082EH (402095)		
7 – 36	0724H (401829)	8 – 47	082FH (402096)		
7 – 37	0725H (401830)	8 – 48	0830H (402097)		
7 – 38	0726H (401831)	8 – 49	0831H (402098)		
7 – 39	0727H (401832)	8 – 50	0832H (402099)		
7 – 40	0728H (401833)	8 – 51	0833H (402100)		
7 – 45	072DH (401838)	8 – 52	0834H (402101)		
		8 – 53	0835H (402102)		
		8 – 54	0836H (402103)		
		8 – 55	0837H (402104)		
		8 – 56	0838H (402105)		
		8 – 57	0839H (402106)		
		8 – 58	083AH (402107)		
		8 – 59	083BH (402108)		
		8 – 60	083CH (402109)		

Function	Register No	Function	Register No	Function	Register No	Function	Register No
Group 12		Group 13		Group 14		Group 14	
12 – 00	Hi-WORD: 2510H (409489) Lo-WORD: 2511H (409490)	13 – 00	0D00H (403329)	14 – 00	0E00H (403585)	14 – 36	0E24H (403621)
12 – 01	0C01H (403074)	13 – 01	0D01H (403330)	14 – 01	0E01H (403586)	14 – 37	0E25H (403622)
12 – 02	0C02H (403075)	13 – 02	0D02H (403331)	14 – 02	0E02H (403587)	14 – 38	0E26H (403623)
12 – 03	0C03H (403076)	13 – 03	0D03H (403332)	14 – 03	0E03H (403588)	14 – 39	0E27H (403624)
12 – 04	0C04H (403077)	13 – 04	0D04H (403333)	14 – 04	0E04H (403589)	14 – 40	0E28H (403625)
12 – 05	0C05H (403078)	13 – 05	0D05H (403334)	14 – 05	0E05H (403590)	14 – 41	0E29H (403626)
12 – 06	0C06H (403079)	13 – 06	0D06H (403335)	14 – 06	0E06H (403591)	14 – 42	0E2AH (403627)
12 – 07	0C07H (403080)	13 – 07	0D07H (403336)	14 – 07	0E07H (403592)	14 – 43	0E2BH (403628)
12 – 11	0C0BH (403084)	13 – 08	0D08H (403337)	14 – 08	0E08H (403593)	14 – 44	0E2CH (403629)
12 – 12	0C0CH (403085)	13 – 10	0D0AH (403339)	14 – 09	0E09H (403594)	14 – 45	0E2DH (403630)
12 – 13	0C0DH (403086)	13 – 51	0D33H (403380)	14 – 10	0E0AH (403595)	14 – 46	0E2EH (403631)
12 – 14	0C0EH (403087)			14 – 11	0E0BH (403596)	14 – 47	0E2FH (403632)
12 – 15	0C0FH (403088)			14 – 12	0E0CH (403597)		
12 – 16	0C10H (403089)			14 – 13	0E0DH (403598)		
12 – 17	0C11H (403090)			14 – 14	0E0EH (403599)		
12 – 19	0C13H (403092)			14 – 15	0E0FH (403600)		
12 – 20	0C14H (403093)			14 – 16	0E10H (403601)		
12 – 28	0C1CH (403101)			14 – 17	0E11H (403602)		
12 – 29	0C1DH (403102)			14 – 18	0E12H (403603)		
12 – 36	0C24H (403109)			14 – 19	0E13H (403604)		
12 – 37	0C25H (403110)			14 – 20	0E14H (403605)		
12 – 38	0C26H (403111)			14 – 21	0E15H (403606)		
12 – 39	0C27H (403112)			14 – 22	0E16H (403607)		
12 – 41	0C29H (403114)			14 – 23	0E17H (403608)		
12 – 43	0C2BH (403116)			14 – 24	0E18H (403609)		
12 – 82	0C52H (403115)			14 – 25	0E19H (403610)		
				14 – 26	0E1AH (403611)		
				14 – 27	0E1BH (403612)		
				14 – 28	0E1CH (403613)		
				14 – 29	0E1DH (403614)		
				14 – 30	0E1EH (403615)		
				14 – 31	0E1FH (403616)		
				14 – 32	0E20H (403617)		
				14 – 33	0E21H (403618)		
				14 – 34	0E22H (403619)		
				14 – 35	0E23H (403620)		

Function	Register No	Function	Register No	Function	Register No
Group 15		Group 16		Group 17	
15 – 00	0F00H (403841)	16 – 00	1000H (404097)	17 – 00	1100H (404353)
15 – 01	0F01H (403842)	16 – 01	1001H (404098)	17 – 01	1101H (404354)
15 – 02	0F02H (403843)	16 – 02	1002H (404099)	17 – 02	1102H (404355)
15 – 03	0F03H (403844)	16 – 03	1003H (404100)	17 – 03	1103H (404356)
15 – 04	0F04H (403845)	16 – 04	1004H (404101)	17 – 04	1104H (404357)
15 – 05	0F05H (403846)	16 – 05	1005H (404102)	17 – 05	1105H (404358)
15 – 06	0F06H (403847)	16 – 06	1006H (404103)	17 – 06	1106H (404359)
15 – 07	0F07H (403848)	16 – 07	1007H (404104)	17 – 08	1108H (404361)
15 – 08	0F08H (403849)	16 – 08	1008H (404105)	17 – 09	1109H (404362)
15 – 09	0F09H (403850)	16 – 09	1009H (404106)	17 – 10	110AH (404363)
15 – 10	0F0AH (403851)			17 – 11	110BH (404364)
15 – 11	0F0BH (403852)			17 – 12	110CH (404365)
15 – 12	0F0CH (403853)			17 – 13	110DH (404366)
15 – 13	0F0DH (403854)			17 – 14	110EH (404367)
15 – 14	0F0EH (403855)				
15 – 15	0F0FH (403856)				
15 – 16	0F10H (403857)				
15 – 17	0F11H (403858)				
15 – 18	0F12H (403859)				
15 – 19	0F13H (403860)				
15 – 20	0F14H (403861)				
15 – 21	0F15H (403862)				
15 – 22	0F16H (403863)				
15 – 23	0F17H (403864)				
15 – 24	0F18H (403865)				
15 – 25	0F19H (403866)				
15 – 26	0F1AH (403867)				
15 – 27	0F1BH (403868)				
15 – 28	0F1CH (403869)				
15 – 29	0F1DH (403870)				
15 – 30	0F1EH (403871)				
15 – 31	0F1FH (403872)				
15 – 32	0F20H (403873)				

6.2 BACnet Protocol Descriptions

The TD400 AC Drive has a built-in BACnet MS/TP communication protocol. Control or monitor the AC Drive via BACnet allowing for reading and writing of specific parameters. The BACnet implementation supports the following standard objects:

- AC Drive Objects
- Analog Input
- Digital Input
- Analog Output
- Digital Output
- Analog Value
- Digital Value

Refer to the table below for property information of each object. User can retrieve object properties using the dedicated BACnet software to control or monitor the AC Drive.

Property	AC Drive (DEV)	Analog Input (AI)	Analog Output (AO)	Analog Value (AV)	Digital Input (BI)	Digital Output (BO)	Digital Value (BV)
Object_Identifier	V	V	V	V	V	V	V
Object_Name	V	V	V	V	V	V	V
Object_Type	V	V	V	V	V	V	V
System_Status	V						
Vendor_Name	V						
Vendor_Identifier	V						
Model_Name	V						
Firmware_Revision	V						
Application_Software_Supported	V						
Protocol_Version	V						
Protocol_Revision	V						
Protocol_Services_Supported	V						
Protocol_Object_Type_Supported	V						
Object_List	V						
Max_APDU_Length_Accepted							
Segmentation_Supported							
APDU_Timeout							
Number_Of_APDU_Retries							
Max_Masters	V						
Max_Info_Frames	V						
Device_Address_Binding							
Location	V						
Present_Value		V	V	V	V	V	V
Status_Flags							
Event_State							
Reliability							
Out_Of_Service							
Units		V	V	V			
Priority_Array							
Relinquish_Default							
Polarity							
Inactive_Text							
Active_Text							

6.2.1 BACnet Object Properties

This section gives an overview of the BACnet objects supported by the AC Drive.

AC Drive Property List

Property	AC Drive
Object_Identifier	DEV
Object_Name	VFD
Object_Type	8
System_Status	0
Vendor_Name	VFD
Vendor_Identifier	461
Model_Name	VFD
Firmware_Revision	0.14
Application_Software_Supported	0.14
Protocol_Version	1
Protocol_Revision	5
Protocol_Services_Supported	{ readProperty , writeProperty , who is }
Protocol_Object_Type_Supported	Analog_Input , Analog_Output, Analog_ValueBinary_Input, Binary_Output, Binary_Value, Device
Max_Masters	127
Max_Info_Frames	1

Analog Input Property List (READ)

No.	Object Name	Description	Unit	Classification	Range
AI0	TM2 AIN	AI1 input	Volt	R	0 - 10
AI1	TM2 AIN2	AI2 input	Volt	R	0 - 10
AI2	Error code	Recent fault message	No Units	R	0 - 45
AI3	Freq cmd	Frequency command	Hz	R	0 - 60
AI4	Frequency	Output frequency	Hz	R	0 - 60
AI5	Current	Output current	Amps	R	
AI6	Control Mode	Control mode	No Units	R	0 - 2
AI7	Motor R-Volt	Motor rated voltage	Volt	R	
AI8	Motor R-HP	Motor rated power	horsepower	R	
AI9	Motor R-RPM	Motor rated rotation speed	No Units	R	
AI10	Motor R-Hz	Motor rated frequency	Hz	R	
AI11	CarrierFreq	Carrier frequency	kHz	R	4 - 16
AI12	Comm Station	INV communication station	No Units	R	1 - 254
AI13	BaudRate	Baud rate setting	No Units	R	0 - 3
AI14	BacnetSel	Communication mode selection	No Units	R	0 - 1
AI15	DevInstance	AC Drive number	No Units	R	1 - 254

Analog Output Property List (READ/WRITE)

No.	Object Name	Description	Unit	Classification	Range
AO0	Set frequency	Frequency command	Hz	R/W	0-599
AO1	TB2 AO1	Analog output voltage 1	Volt	R	0-10
AO2	-	-	-	-	-
AO3	Motor R-Amp	Motor rated current	Amps	R/W	0-65535
AO4	PwrL Sel	Momentary stop and restart selection	No Units	R	0-1
AO5	RestartSel	Number of Fault Auto-Restart Attempts	No Units	R	0-10
AO6	RestartDelay	Fault Auto-Restart Time	No Units	R	0-7200
AO7	FreqCommand1	Speed frequency setting-stage 0	seconds	R/W	0-599
AO8	FreqCommand2	Speed frequency setting-stage 1	Hz	R/W	0-599
AO9	FreqCommand3	Speed frequency setting-stage 2	Hz	R/W	0-599
AO10	FreqCommand4	Speed frequency setting-stage 3	Hz	R/W	0-599
AO11	FreqCommand5	Speed frequency setting-stage 4	Hz	R/W	0-599
AO12	FreqCommand6	Speed frequency setting-stage 5	Hz	R/W	0-599
AO13	FreqCommand7	Speed frequency setting-stage 6	Hz	R/W	0-599
AO14	FreqCommand8	Speed frequency setting-stage 7	Hz	R/W	0-599
AO15	FreqCommand9	Speed frequency setting-stage 8	Hz	R/W	0-599
AO16	FreqCommand10	Speed frequency setting-stage 9	Hz	R/W	0-599
AO17	FreqCommand11	Speed frequency setting-stage 10	Hz	R/W	0-599
AO18	FreqCommand12	Speed frequency setting-stage 11	Hz	R/W	0-599
AO19	FreqCommand13	Speed frequency setting-stage 12	Hz	R/W	0-599
AO20	FreqCommand14	Speed frequency setting-stage 13	Hz	R/W	0-599
AO21	FreqCommand15	Speed frequency setting-stage 14	Hz	R/W	0-599
AO22	FreqCommand16	Speed frequency setting-stage 15	Hz	R/W	0-599
AO23	RunMode	Main run command source	Hz	R/W	0-2
AO24	ReverseOper	Direction locked command	No Units	R/W	0-1
AO25	StoppingSel	Stop modes selection	No Units	R/W	0-1
AO26	FrequencyComm	Main frequency command source	No Units	R/W	0-5
AO27	FreqUpperLim	Upper limit frequency	No Units	R/W	0-599
AO28	FreqLowerLim	Lower limit frequency	HZ	R/W	0-598.99
AO29	Acc Time1	Acceleration time 1	HZ	R/W	0-6000.0
AO30	Dec Time1	Deceleration time 1	seconds	R/W	0-6000.0

Analog Value Property List (READ/WRITE)

No.	Object Name	Description	Unit	Classification	Range
AV0	PID – P Gain	Proportional gain (P)	No Units	R/W	0 - 10
AV1	PID – I Time	Integral time (I)	No Units	R/W	0 - 100
AV2	PID – D Time	Differential time (D)	No Units	R/W	0 – 10

Digital Input Property List (READ)

No.	Object Name	Description	Unit	Classification	Range
BI0	Run/Stop	Operation status	Stop / Run	R	0 - 1
BI1	Direction	Operation direction	FWD/REV	R	0 - 1
BI2	status	AC Drive status	OK/Fault	R	0 - 1
BI3	Abnormal	Error occurs	Close/Open	R	0 - 1
BI4	DI_1 status	S1 status	Close/Open	R	0 - 1
BI5	DI_2 status	S2 status	Close/Open	R	0 - 1
BI6	DI_3 status	S3 status	Close/Open	R	0 - 1
BI7	DI_4 status	S4 status	Close/Open	R	0 - 1
BI8	DI_5 status	S5 status	Close/Open	R	0 - 1
BI9	DI_6 status	Operation status	Close/Open	R	0 - 1

Digital Output Property List (READ/WRITE)

No.	Object Name	Description	Unit	Classification	Range
BO0	RY1 status	Relay output 1 status	Close/Open	R	0 - 1
BO1	RY2 status	Relay output 2 status	Close/Open	R	0 - 1
BO2	-	-	-	-	-

Digital Value property List (READ/WRITE)

No.	Object Name	Description	Unit	Classification	Range
BV0	RUN/STOP	RUN/STOP	Stop / Run	R/W	0 - 1
BV1	FWD/REV	FWD/REV	FWD/REV	R/W	0 - 1

7. Troubleshooting, Fault Diagnostics and Maintenance

7.1 General

AC Drive fault detection and early warning / self-diagnosis function. When the AC Drive detects a fault, a fault message is displayed on the keypad.

When the AC Drive detects a warning / self-diagnostics error, the digital operator will display a warning or self-diagnostic code. The fault output does not energize in this case. Once the warning is removed, the system will automatically return to its original state.


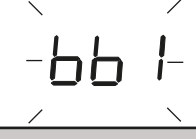
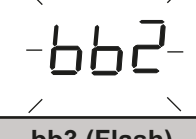
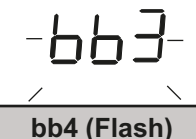
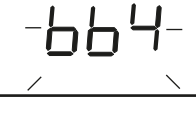
7.2 Fault Detection Function

When a fault occurs, refer to Table 7.2.1 for possible causes and appropriate measures. The fault message is stored in the fault history (see group 12 parameters).


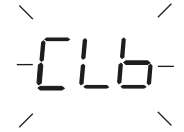

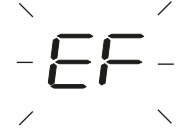


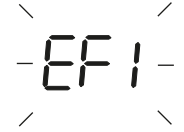
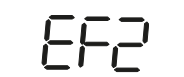
Use one of the following methods to restart:


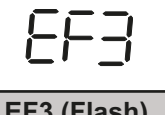

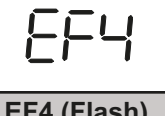




1. Set one of multi-function digital input terminals (03-00 to 03-05) to 17 (Fault reset) and activate the input
2. Press the STOP/RESET button on the keypad.
3. Power down AC Drive, wait until keypad goes blank, and power-up the AC Drive again.


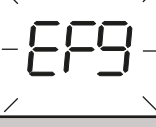

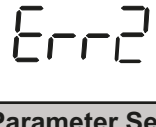
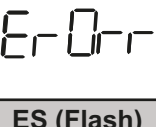
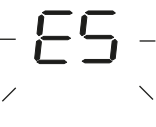

Table 7.2.1 Fault Information and Possible Solutions









LED Display	Description	Cause	Possible Solutions
Voltage on C/B Error 	Control board voltage error.	<ul style="list-style-type: none"> • Error detecting voltages • Too much noise • Control board failure 	<ul style="list-style-type: none"> • Check the voltage on the control board.
bb1 (Flash) External Baseblock 	External base block (Terminal S1)	<ul style="list-style-type: none"> • Multifunction digital input external baseblock active. 	<ul style="list-style-type: none"> • Multi-function input function set incorrectly. • Check wiring
bb2 (Flash) External Baseblock 	External base block (Terminal S2)		
bb3 (Flash) External Baseblock 	External base block (Terminal S3)		
bb4 (Flash) External Baseblock 	External base block (Terminal S4)		








LED Display	Description	Cause	Possible Solutions
bb5 (Flash) External Baseblock 	External base block (Terminal S5)	<ul style="list-style-type: none"> • Multifunction digital input external baseblock active. 	<ul style="list-style-type: none"> • Multi-function input function set incorrectly. • Check wiring
bb6 (Flash) External Baseblock 	External base block (Terminal S6)		
Control Board Error 	Firmware can't write to Control board.	<ul style="list-style-type: none"> • Firmware not compatible with Control board. 	<ul style="list-style-type: none"> • Replace the control board.
Comm. Error 	No Modbus communication received for the time specified in 09-06 (communication error detection time). Active when 09-07 = 0 to 2	<ul style="list-style-type: none"> • Connection lost or wire broken. • Host stopped communicating. 	<ul style="list-style-type: none"> • Check connection. • Check host computer/ software.
CE (Flash) Communication Error 	No Modbus communication received for 2 sec. Active when 09-07=3.	<ul style="list-style-type: none"> • Connection lost or wire break. • Host stopped communicating. 	<ul style="list-style-type: none"> • Check connection • Check host computer/ software.
Operator Comm. Error 	Communication error between AC Drive and LCD keypad.	<ul style="list-style-type: none"> • LCD keypad and AC Drive cannot transmit data after power on 5 seconds. 	<ul style="list-style-type: none"> • Disconnect the operator and then reconnect. • Replace control board.
Operator Communication Error 2 	Communication error between AC Drive and LCD keypad.	<ul style="list-style-type: none"> • LCD keypad and AC Drive can transmit data but transmission error occurs for more than 2 seconds 	<ul style="list-style-type: none"> • Disconnect the operator and then reconnect. • Replace control board.
Motor Control Fault 	Motor control fault	<ul style="list-style-type: none"> • SLV mode is unable to run motor. 	<ul style="list-style-type: none"> • Perform rotational or stationary auto-tune • Increase minimum output frequency (01-08)








LED Display	Description	Cause	Possible Solutions
Motor Control Fault			<ul style="list-style-type: none"> • Increase the value of 22-10 and 22-23. • Perform auto-tune (22-21) • Check if the load is too heavy to raise torque output limit.
	Motor control fault	<ul style="list-style-type: none"> • Start or Run fault in PMSLV mode 	
Over Current Protection Level B			
	AC Drive current reaches the current protection level B.	<ul style="list-style-type: none"> • AC Drive current too high. • Load too heavy. 	<ul style="list-style-type: none"> • Check load and application duty cycle.
Current Transducer Error			
	Three phase input voltage detection level error	<ul style="list-style-type: none"> • Input voltage abnormal • Input voltage noise is too high • Control board malfunction 	<ul style="list-style-type: none"> • Check input voltage and the voltage signal of control board
Run Command Error			
	Single direction operation only, AC Drive cannot receive a reverse operation command at the same time a forward command is active.	<ul style="list-style-type: none"> • Check terminal for reverse operation command. 	<ul style="list-style-type: none"> • Disconnect reverse operation command from external terminal.
External Fault 0			
	External fault (Modbus)	<ul style="list-style-type: none"> • Modbus communication 0x2501 bit 2 = "1" 	<ul style="list-style-type: none"> • Reset Modbus communication 0x2501 bit 2 = "1"
External Fault (S1)			
	External fault (Terminal S1) Active when 03-00= 25 and AC Drive external fault selection 08-24=0 or 1.	<ul style="list-style-type: none"> • Multifunction digital input external fault active. 	<ul style="list-style-type: none"> • Multi-function input function set incorrectly. • Check wiring
EF1 (Flash) External Fault (S1)			
	External fault (Terminal S1). Active when 03-00= 25 and AC Drive external fault selection 08-24=2.	<ul style="list-style-type: none"> • Multifunction digital input external fault active 	<ul style="list-style-type: none"> • Multi-function input function set incorrectly. • Check wiring.
External Fault (S2)			
	External fault (Terminal S2) Active when 03-01= 25, and AC Drive external fault selection 08-24=0 or 1.	<ul style="list-style-type: none"> • Multifunction digital input external fault active. 	<ul style="list-style-type: none"> • Multi-function input function set incorrectly. • Check wiring

LED Display	Description	Cause	Possible Solutions
EF1 (Flash) External Fault (S2)	External fault (Terminal S2). Active when 03-01= 25 and AC Drive external fault selection 08-24=2.	<ul style="list-style-type: none"> • Multifunction digital input external fault active 	<ul style="list-style-type: none"> • Multi-function input function set incorrectly. • Check wiring.
			
External Fault (S3)	External fault (Terminal S3) Active when 03-02= 25 and AC Drive external fault selection 08-24=0 or 1.	<ul style="list-style-type: none"> • Multifunction digital input external fault active. 	<ul style="list-style-type: none"> • Multi-function input function set incorrectly. • Check wiring
			
EF3 (Flash) External Fault (S3)	External fault (Terminal S3). Active when 03-02= 25 and AC Drive external fault selection 08-24=2.	<ul style="list-style-type: none"> • Multifunction digital input external fault active. 	<ul style="list-style-type: none"> • Multi-function input function set incorrectly. • Check wiring.
			
External Fault (S4)	External fault (Terminal S4) Active when 03-03= 25 and AC Drive external fault selection 08-24=0 or 1.	<ul style="list-style-type: none"> • Multifunction digital input external fault active. 	<ul style="list-style-type: none"> • Multi-function input function set incorrectly. • Check wiring
			
EF4 (Flash) External Fault (S4)	External fault (Terminal S4). Active when 03-03= 25 and AC Drive external fault selection 08-24=2.	<ul style="list-style-type: none"> • Multifunction digital input external fault active. 	<ul style="list-style-type: none"> • Multi-function input function set incorrectly. • Check wiring.
			
External Fault (S5)	External fault (Terminal S5) Active when 03-04= 25 and AC Drive external fault selection 08-24=0 or 1.	<ul style="list-style-type: none"> • Multifunction digital input external fault active. 	<ul style="list-style-type: none"> • Multi-function input function set incorrectly. • Check wiring
			
EF5 (Flash) External Fault (S5)	External fault (Terminal S5). Active when 03-04= 25 and AC Drive external fault selection 08-24=2.	<ul style="list-style-type: none"> • Multifunction digital input external fault active. 	<ul style="list-style-type: none"> • Multi-function input function set incorrectly. • Check wiring.
			
External Fault (S6)	External fault (Terminal S6) Active when 03-05= 25 and AC Drive external fault selection 08-24=0 or 1.	<ul style="list-style-type: none"> • Multifunction digital input external fault active. 	<ul style="list-style-type: none"> • Multi-function input function set incorrectly. • Check wiring
			




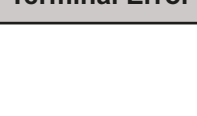


LED Display	Description	Cause	Possible Solutions
EF6 (Flash) External Fault (S6)	External fault (Terminal S6). Active when 03-05= 25 and AC Drive external fault selection 08-24=2.	<ul style="list-style-type: none"> • Multifunction digital input external fault active. 	<ul style="list-style-type: none"> • Multi-function input function set incorrectly. • Check wiring.
			
EF9 (Flash) Error Of Fwd/Rev Rotation	Forward run and reverse run are active within 0.5 sec of each other. Stop method set by parameter 07-09.	<ul style="list-style-type: none"> • Forward run and reverse run active (see 2-wire control). 	<ul style="list-style-type: none"> • Check run command wiring.
			
EEPROM Save Error	The data saved in EEPROM is wrong.	<ul style="list-style-type: none"> • EEPROM circuit failure. • Parameter check error after power on. 	<ul style="list-style-type: none"> • Restore factory setting, then power off and on again. If warning reoccurs, replace control board.
			
Set Password Failed	Parameter key code entered is incorrect.	<ul style="list-style-type: none"> • To disable parameter lock, key code must be correct. 	<ul style="list-style-type: none"> • Enter the correct code for 13-07 to enable the parameter lock.
			
Parameter Set Error	Keypad operation error	<ul style="list-style-type: none"> • Attempting to modify a parameter that cannot be modified while in operation 	<ul style="list-style-type: none"> • Modify parameter when stopped.
			
ES (Flash) External Emergency Stop	External emergency stop Enabled.	<ul style="list-style-type: none"> • 03-00 to 03-05 set to 14 and digital input is active. 	<ul style="list-style-type: none"> • Turn off run command, and remove external emergency stop command.
			
PID Feedback Loss	PID feedback signal falls below level specified in 10-12 (PID feedback loss detection level) for the time specified in 10-13 (Feedback loss detection time). Active when parameter 10-11 = 2.	<ul style="list-style-type: none"> • Feedback signal wire broken • Feedback sensor broken. 	<ul style="list-style-type: none"> • Check feedback wiring. • Replace feedback sensor.
			










LED Display	Description	Cause	Possible Solutions
FB (Flash) PID Feedback Breaking	PID feedback signal falls below level specified in 10-12 (PID feedback loss detection level) for the time specified in 10-13 (Feedback loss detection time).	<ul style="list-style-type: none"> ● Feedback signal wire break ● Feedback sensor broken. 	<ul style="list-style-type: none"> ● Check feedback wiring ● Replace feedback sensor.
	Active when parameter 10-11 = 1.		
Fire Mode Enabled	Fire mode enabled	<ul style="list-style-type: none"> ● Fire mode enabled. 	<ul style="list-style-type: none"> ● Check for cause of fire mode activation. If it is OK to deactivate fire mode, turn the power off and on again.
			
Ground Fault	The ground fault exceeds 50% of the AC Drive rated output current (If 08-23 = 1, GF function is enabled).	<ul style="list-style-type: none"> ● Motor damaged (insulation). ● Wire damage or deterioration. ● AC Drive DCCT sensors defect. 	<ul style="list-style-type: none"> ● Replace motor. ● Check motor wiring. ● Disconnect motor and try running AC Drive. ● Check resistance between cables and ground. ● Reduce carrier frequency.
			
Model Select Error	AC Drive capacity setting error: AC Drive capacity setting 13-00 does not match the rated voltage.	<ul style="list-style-type: none"> ● AC Drive capacity setting does not match voltage class (13-00). 	<ul style="list-style-type: none"> ● Check AC Drive capacity setting 13-00.
			
Input Phase Loss	Phase loss at the input side of the AC Drive or input voltage imbalance, active when 08-09 = 1 (enabled).	<ul style="list-style-type: none"> ● Loose wire at AC Drive input terminal. ● Momentary power loss. ● Input voltage imbalance. 	<ul style="list-style-type: none"> ● Check input wiring. ● Fasten wire terminal screws. ● Check power supply.
			
Parameter Lock	AC Drive parameters locked.	<ul style="list-style-type: none"> ● Parameter lock key code is active (13-07) 	<ul style="list-style-type: none"> ● Remove parameter lock, by entering the correct code in parameter for 13-07
			
Low Voltage (Solid or Flash)	DC bus voltage is lower than the UV detection level or the pre-charge contactor is not active while the AC Drive is running. 240V class: 190Vdc 480V class: 380Vdc (Detection value can be adjusted by parameter 07-13).	<ul style="list-style-type: none"> ● The input voltage is too low. ● Input phase loss. ● Acceleration time set too short. ● Input voltage fluctuation. ● Pre-charge contactor damaged. ● DC bus voltage feedback signal value incorrect. 	<ul style="list-style-type: none"> ● Check the input voltage. ● Check input wiring. ● Increase acceleration time. ● Check power source ● Replace pre-charge contactor ● Replace control board or AC Drive.
 			

LED Display	Description	Cause	Possible Solutions
Over Current	<p>The AC Drive output current exceeds the overcurrent level (200% of the AC Drive rated current).</p>	<ul style="list-style-type: none"> Acceleration / Deceleration time is set too short. Contactor installed on the output side of AC Drive. Motor rating exceeds AC Drive rating. Short circuit or ground fault. 	<ul style="list-style-type: none"> Extend acceleration / deceleration time. Check the motor wiring. Disconnect motor and try running AC Drive.
			
Over Current	<p>The AC Drive output current exceeds the overcurrent level in acceleration time</p>	<ul style="list-style-type: none"> Acceleration time set too short Motor rating exceeds AC Drive rating. Short circuit between winding and motor casing Short circuit between wire and motor ground IGBT failure 	<ul style="list-style-type: none"> Set a longer acceleration time Change to a larger capacity AC Drive Examine motor Check wiring Replace IGBT module
			
Over Current	<p>The AC Drive output current exceeds the overcurrent level in acceleration time</p>	<ul style="list-style-type: none"> Acceleration time set too short Motor exceeds AC Drive rating Short circuit between motor winding and motor casing Short circuit between wire and ground of motor IGBT failure 	<ul style="list-style-type: none"> Set a longer acceleration time Change to a larger capacity AC Drive Check motor Check wiring Replace IGBT module
			
Over Current	<p>The AC Drive output current exceeds the overcurrent level during deceleration</p>	<ul style="list-style-type: none"> Deceleration time is set too short 	<ul style="list-style-type: none"> Set longer deceleration time
			
OH1 Heatsink Overheat (Solid or Flash)	<p>The temperature of the heat sink is too high. Note: When OH1 fault occurs three times within five minutes, user must wait 10 minutes before the AC Drive can be reset.</p>	<ul style="list-style-type: none"> Ambient temperature too high. Cooling fan failed. Carrier frequency set too high. Load too heavy. 	<ul style="list-style-type: none"> Install fan or AC to cool surroundings. Replace cooling fan. Reduce carrier frequency. Reduce load / Measure output current
			
			
OH2 (Flash) AC Drive Over Heating Warning	<p>AC Drives overheat warning. Multi-function digital input set to 31. (03-00-03-05=31)</p>	<ul style="list-style-type: none"> Multifunction digital input overheat warning active 	<ul style="list-style-type: none"> Multi-function input function set incorrectly. Check wiring
			

LED Display	Description	Cause	Possible Solutions
OH4 Motor Overheating	Motor overheating, PTC (Positive Temperature Coefficient) exceeds the overheat protection level.	<ul style="list-style-type: none"> • The surrounding temperature of the motor is too high. • The PTC input (Positive Temperature Coefficient) exceeds the overheat protection level. 	<ul style="list-style-type: none"> • Check the surrounding temperature of the motor. • Check the motor and GND terminal wiring.
			
OL1 Motor Overload	Internal motor overload protection tripped, active when protection curve 08-05 = xxx1.	<ul style="list-style-type: none"> • Voltage setting in V/F mode set too high, resulting in over-excitation of the motor. • Motor rated current (02-01) set incorrectly. • Load too heavy. 	<ul style="list-style-type: none"> • Check V/f curve. • Check motor rated current • Check and reduce motor load, check application operation duty cycle.
			
OL2 AC Drive Overload	AC Drive thermal overload protection tripped. If an AC Drive overload occurs 4 times in five minutes, user must wait 4 minutes before resetting the fault.	<ul style="list-style-type: none"> • Voltage setting V/F mode too high, resulting in over-excitation of the motor. • Motor rated current (02-01) set incorrectly. • Load too heavy. 	<ul style="list-style-type: none"> • Check V/f curve. • Check motor rated current • Check and reduce motor load, check application duty cycle
			
Output Phase Loss	Phase loss at the output side of the AC Drive, active when 08-10 = 1 (enabled).	<ul style="list-style-type: none"> • Wiring loose at AC Drive output terminal. • Motor rated current is less than 10% of the AC Drive rated current. 	<ul style="list-style-type: none"> • Check output wiring / fasten screws. • Check motor & AC Drive rating.
			
Operator Disconnection	When 00-02=0 and operator is disconnected while AC Drive is running. Fault action selection set by parameter 16-09.	<ul style="list-style-type: none"> • When 00-02=0, warning is displayed when operator is disconnected. 	<ul style="list-style-type: none"> • Check the keypad operator connection.
			
OT Over Torque Detection (Solid or Flash)	AC Drive output torque is higher than 08-15 (over torque detection level) for the time specified in 08-16. Parameter 08-14 = 0 to activate.	<ul style="list-style-type: none"> • Load too heavy. 	<ul style="list-style-type: none"> • Check over torque detection parameters (08-15 / 08-16). • Check and reduce motor load, check and operation duty cycle.
 			

LED Display	Description	Cause	Possible Solutions
Over Voltage (Solid or Flash)	DC bus voltage exceeds the OV detection level: 240V class: 410Vdc 480V class: 820Vdc (For 480V class, if input voltage 01-14 is set lower than 400V, the OV detection value is decreased to 700Vdc)	<ul style="list-style-type: none"> Deceleration time set too short, resulting in regenerative energy flowing back from motor to the AC Drive. The AC Drive input voltage is too high. Use of power factor correction capacitors. Excessive braking load. Braking transistor or resistor defective. Speed search parameters set incorrectly. 	<ul style="list-style-type: none"> Increase deceleration time Reduce input voltage to comply with the input voltage requirements or install an AC line reactor to lower the input voltage. Remove the power factor correction capacitor. Use dynamic braking unit. Replace braking transistor or resistor. Adjust speed search parameters.
Parameter Setting Error	Parameter setting error.	<ul style="list-style-type: none"> The parameter setting is incorrect. 	<ul style="list-style-type: none"> Please refer to parameter listing and details for correct settings
STO Jumper	The Functional Safety Input (STO) circuit is open.	<ul style="list-style-type: none"> Jumper between SF1/SF2 and SG terminals has been removed User created STO circuit is open 	<ul style="list-style-type: none"> Install jumper between SF1/SF2 and SG terminals and press STOP/Reset Adjust user created circuit to close STO
PTC Error (Solid or Flash)	PTC wires disconnected	<ul style="list-style-type: none"> PTC wires disconnected for more than 10 seconds. 	<ul style="list-style-type: none"> Check the motor and GND connection
Keypad Copy Error	Parameters cannot be uploaded to the keypad	<ul style="list-style-type: none"> AC Drive data transmission error, cannot upload the data to keypad 	<ul style="list-style-type: none"> Check keypad and AC drive connection
Read and Save Data Disallowed	Keypad cannot read or save AC Drive parameters	<ul style="list-style-type: none"> When 16-08=0, keypad read/save function disabled. 	<ul style="list-style-type: none"> Check parameter 16-08 setting.
Retry (Flash) Retry	Automatic reset activated, warning is displayed until restart delay time set (07-01) expires.	<ul style="list-style-type: none"> Parameter 07-01 set to a value greater than 0. Parameter 07-02 set to a value greater than 0. 	<ul style="list-style-type: none"> Warning disappears after automatic reset.

LED Display	Description	Cause	Possible Solutions
Wrong Running Direction Error 	Running direction is different from 11-00	<ul style="list-style-type: none"> Direction control selection 11-00 set incorrectly, jog and DI control wired incorrectly. 	<ul style="list-style-type: none"> Revise direction selection 11-00, verify jog and DI control.
Short Circuit 	AC Drive output short circuit or ground fault.	<ul style="list-style-type: none"> Short circuit or ground fault (08-23 = 1). Motor damaged (insulation). Wire damage or deterioration. 	<ul style="list-style-type: none"> Check motor wiring. Disconnect motor and try running the AC Drive.
Range setting error 	Parameter setting falls outside the allowed range.	<ul style="list-style-type: none"> Some parameter ranges are determined by other AC Drive parameters which could cause an out of range warning when the dependent parameter is adjusted. <p>Example: 02-00>02-01, or 02-20>02-21</p>	<ul style="list-style-type: none"> Check parameter settings.
Digital Input Terminal Error 	Multi-function input setting error.	<ul style="list-style-type: none"> Multi-function digital input terminals (03-00 to 03-05) are set to the same function (not including ext. fault) UP/DOWN commands are not set at the same time (they must be used together). UP/DOWN commands (08 and 09) and ACC/DEC commands (11) are set at the same time. Speed search 1 (19: maximum frequency) and Speed search 2 (34: from the set frequency) are set at the same time. 03-00 to 03-05 set two-wire and three-wire at the same time. 	<ul style="list-style-type: none"> Check multi-function input setting.
V/F Curve Error 	V/f curve setting error.	<ul style="list-style-type: none"> V/F curve parameters set improperly. 	<ul style="list-style-type: none"> Check V/F parameters to ensure values are in appropriate order (e.g. minimum frequency higher than rated frequency)
PID Selection Error 	PID selection error.	<ul style="list-style-type: none"> 10-00 and 10-01 set to 1(AI1) or set to 2(AI2). 	<ul style="list-style-type: none"> Check 10-00 and 10-01 Check 10-33 and 10-34

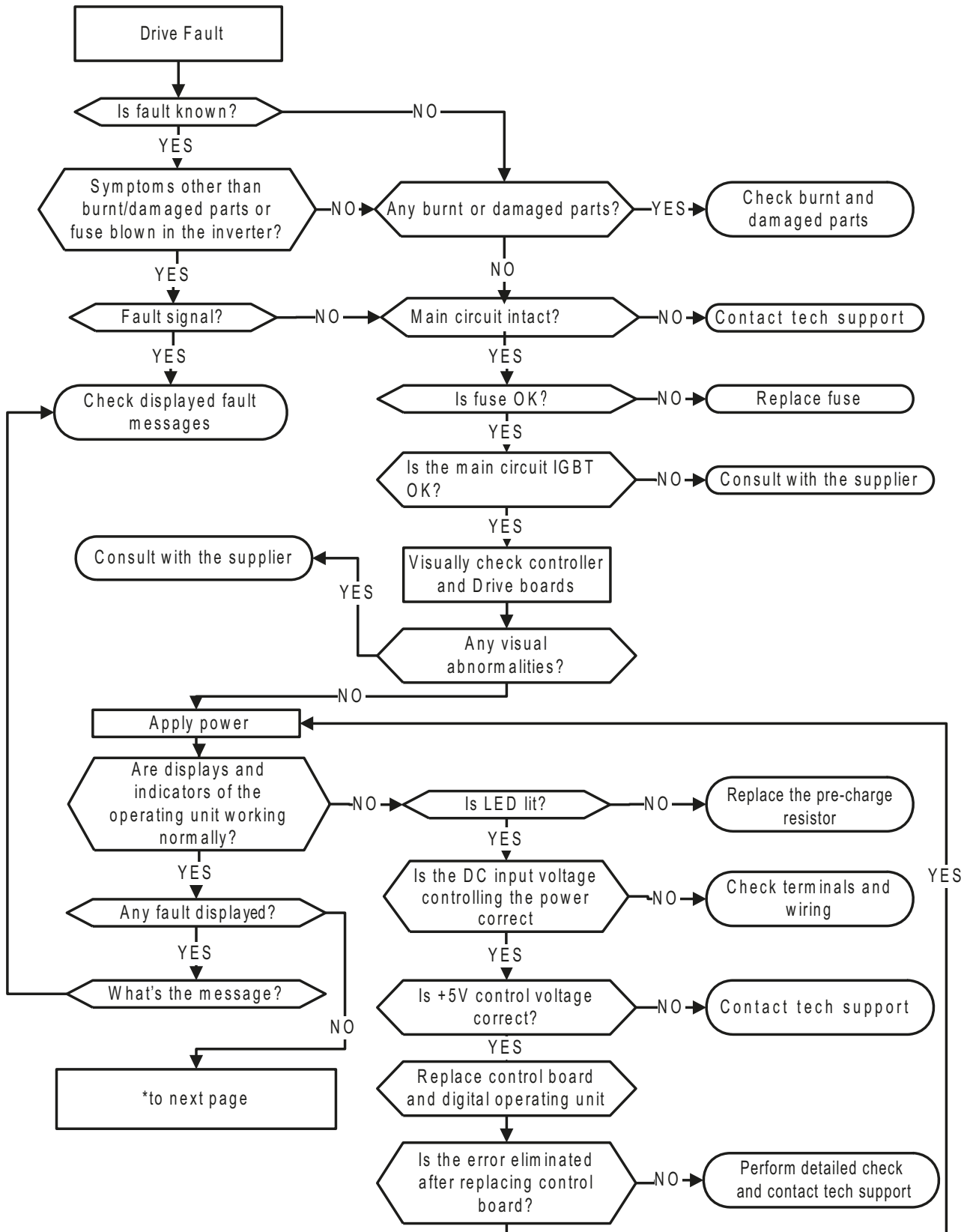
LED Display	Description	Cause	Possible Solutions
PI Setting Error 	AC Drive PI setting error	<ul style="list-style-type: none"> AC Drive pulse input selection (03-30) selection conflicts with PID source (10-00 and 10-01). 	<ul style="list-style-type: none"> Check pulse input selection (03-30) and PID source (10-00 and 10-01).
Safety 1 Error 	STO terminal 1 error	<ul style="list-style-type: none"> Terminal board Input SF1 and SG are not connected 	<ul style="list-style-type: none"> Check SF1 and SG Connection.
Safety 2 Error 	STO terminal 2 error	<ul style="list-style-type: none"> Terminal board Input SF2 and SG are not connected 	<ul style="list-style-type: none"> Check SF2 and SG Connection.
Safety 3 Error 	STO terminal 3 error	<ul style="list-style-type: none"> Transformer voltage output of AC Drive is not stable. 	<ul style="list-style-type: none"> Replace the power board Contact support
Zero Speed Stop Error 	Frequency command below 01-08 without using the DC brake function.	<ul style="list-style-type: none"> Frequency command set below minimum output frequency. 	<ul style="list-style-type: none"> Adjust frequency command.
Direct Start Warning 	The AC Drive can't start directly, due to 07-04=1	<ul style="list-style-type: none"> Run command from the terminal is enabled and 07-04=1 	<ul style="list-style-type: none"> Remove the run command from the terminal first, and enable later.
External Terminal Stop Error 	External Terminal is main run command source selection (00-02=1) and run command executes but executes stop command from keypad.	<ul style="list-style-type: none"> Run command executes from external terminal but executes stop command from keypad. 	<ul style="list-style-type: none"> Remove the run command from external terminal
Keypad Compare Error 	Data comparison failed between keypad and AC Drive.	<ul style="list-style-type: none"> Data in the AC Drive does not match data saved in the keypad. 	<ul style="list-style-type: none"> Check parameters.
Keypad Write Error 	Operator cannot write data to the AC Drive	<ul style="list-style-type: none"> The control mode in the keypad does not match the AC Drive. The model name in the keypad does not match the AC Drive. The firmware version in the keypad does not match the AC Drive. 	<ul style="list-style-type: none"> Check the control mode, model name and firmware version of the AC Drive.

7.3 General Troubleshooting

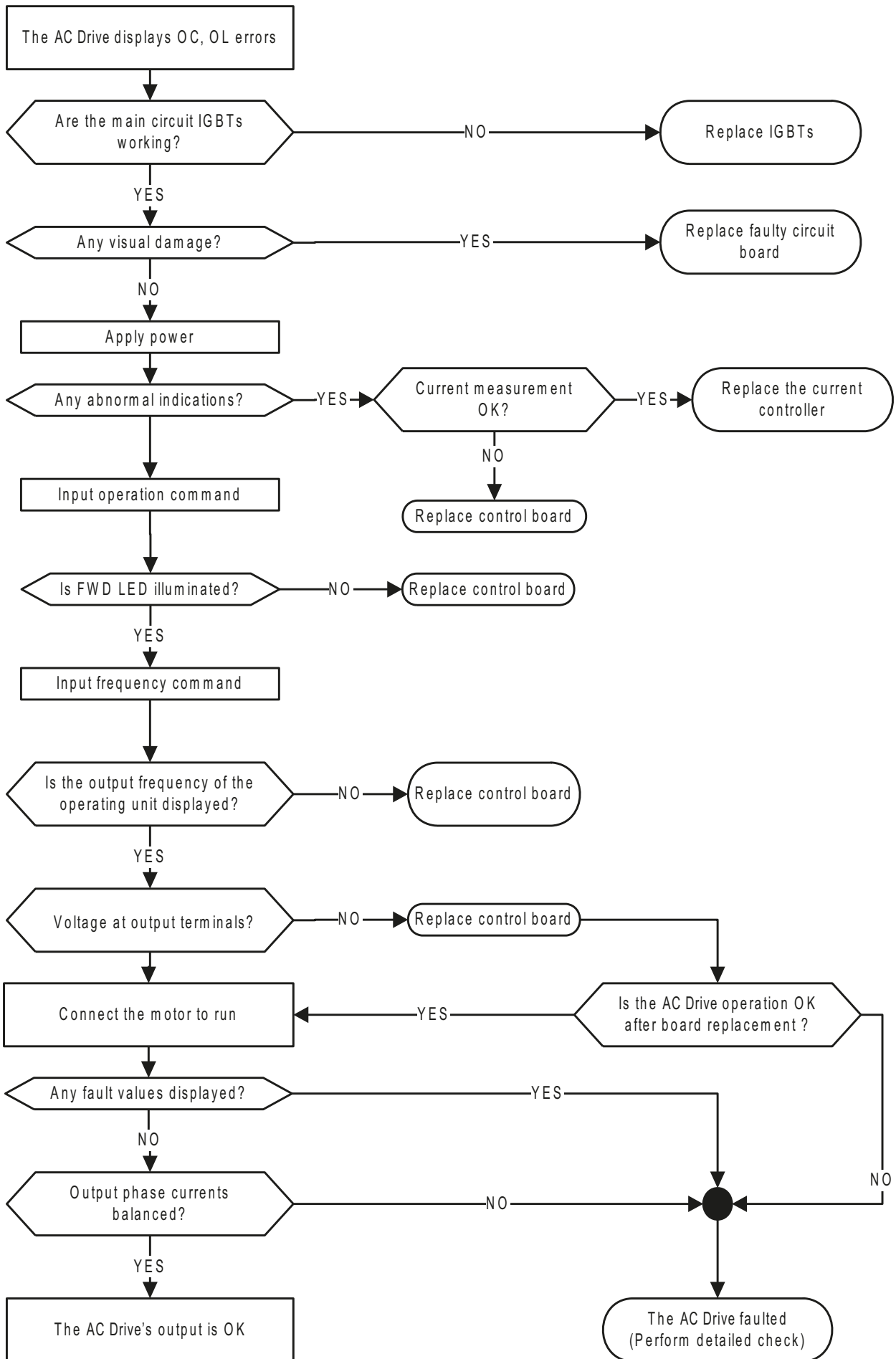
Status	Checking Point	Remedy
Motor runs in wrong direction	Motor wiring correct to AC Drive output terminals?	AC Drive must be connected to U, V, and W terminals of the motor.
	Control wiring correct for forward and reverse commands?	Check wiring.
The motor speed cannot be regulated.	Wiring for the analog frequency reference inputs correct?	Check wiring.
	Operation mode correct?	Check the Frequency source parameters 00-05 and 00-06.
	Is the load too excessive?	Reduce the load.
Motor speed too high or too low	Check the motor specifications (FLA, voltage, max speed...) are correct?	Check motor nameplate.
	Is the gear ratio correct?	Confirm the gear ratio.
	Is the maximum frequency setting correct?	Check maximum frequency settings.
Motor speed unstable	Is the motor load too high?	Reduce motor load.
	Motor load unstable?	(1) Stabilize motor load. (2) Consider increasing AC Drive and motor size.
	Is the input power unstable or is there a phase loss condition?	(1) Consider adding an AC reactor at the power input side. (2) Check wiring when using three-phase power.
Motor does not run	Is input power connected to the correct L1(L), L2, and L3(N) terminals? Charging indicator lit? (select frame sizes only)	(1) Power turned ON? (2) Cycle power to the AC Drive. (3) Make sure the input voltage is correct. (4) Make sure input terminal screws are tight.
	Is there voltage across the output terminals T1, T2, and T3?	Cycle power to the AC Drive.
	Is motor load causing the motor to stall?	Reduce the motor load.
	Are there any errors shown on the AC Drive keypad?	See error descriptions and check wiring, correct if necessary.
	Forward or reverse run command active?	
	Check analog frequency reference signal?	(1) Analog frequency input signal wired correctly? (2) Check analog input voltage of frequency input.
	Operation mode setting correct?	Check AC Drive operation mode 00-02 & 00-03.

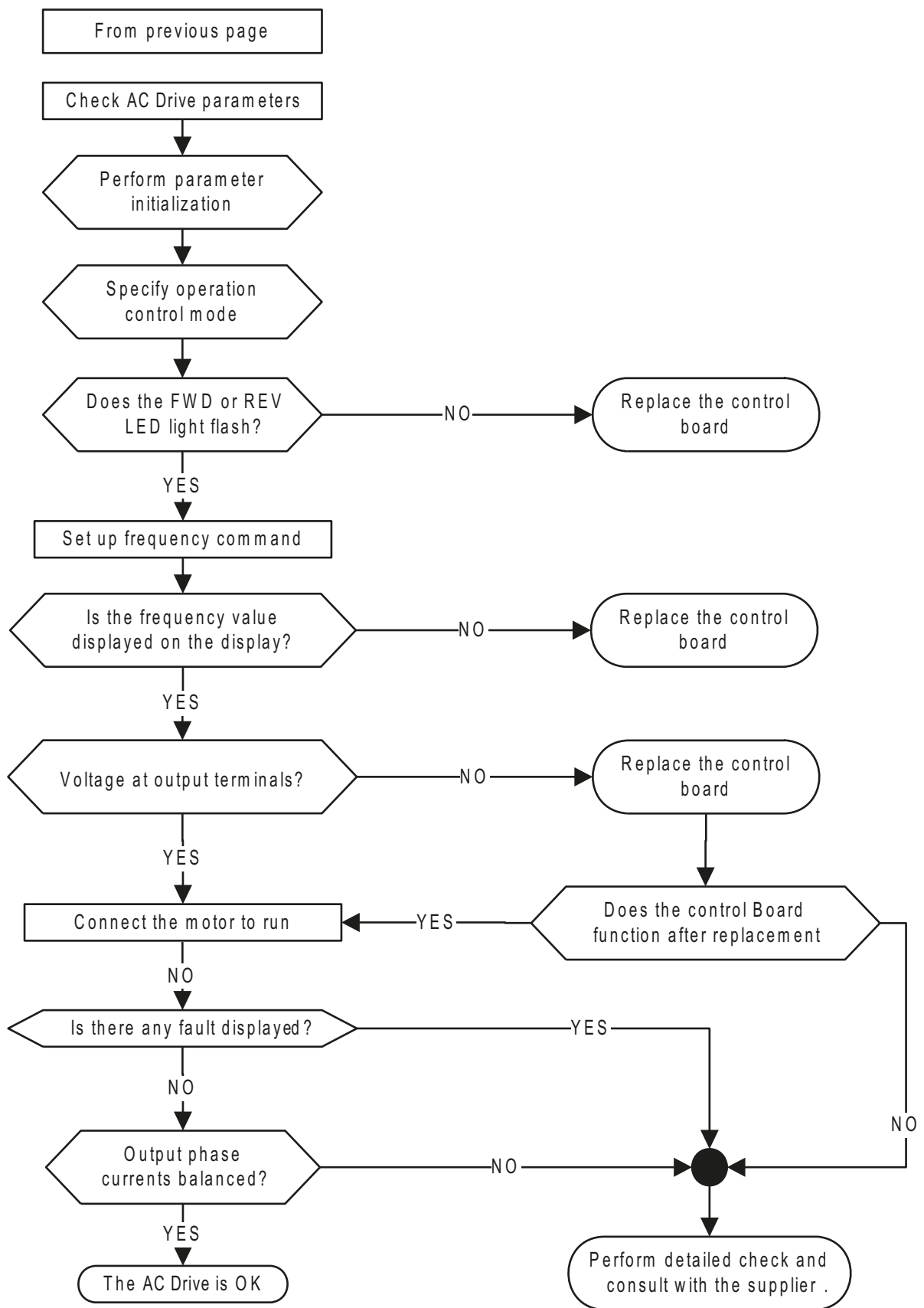
7.4 Troubleshooting Flowcharts

7.4.1 Quick troubleshooting of AC Drive

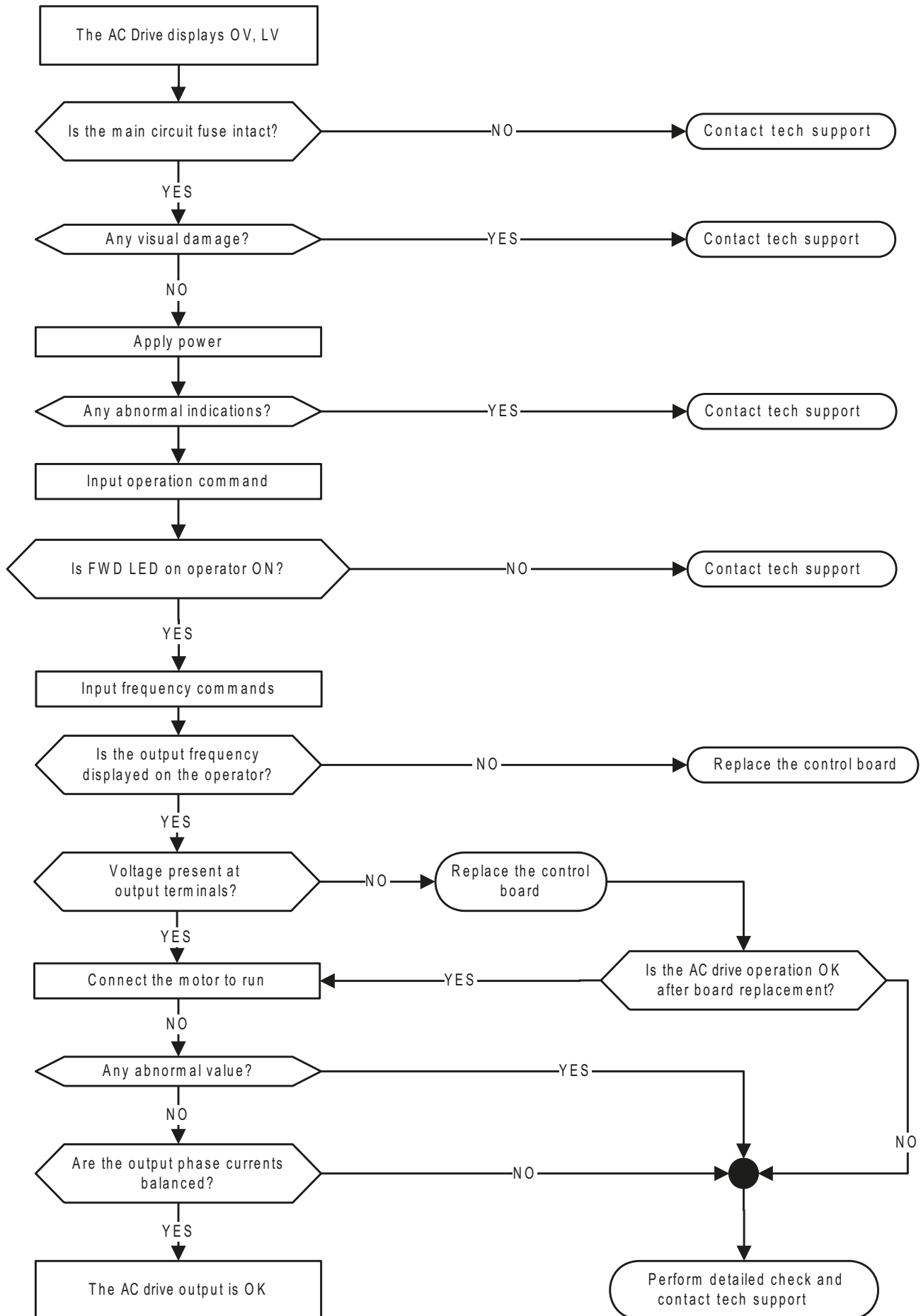


7.4.2 Overcurrent and Overload Troubleshooting

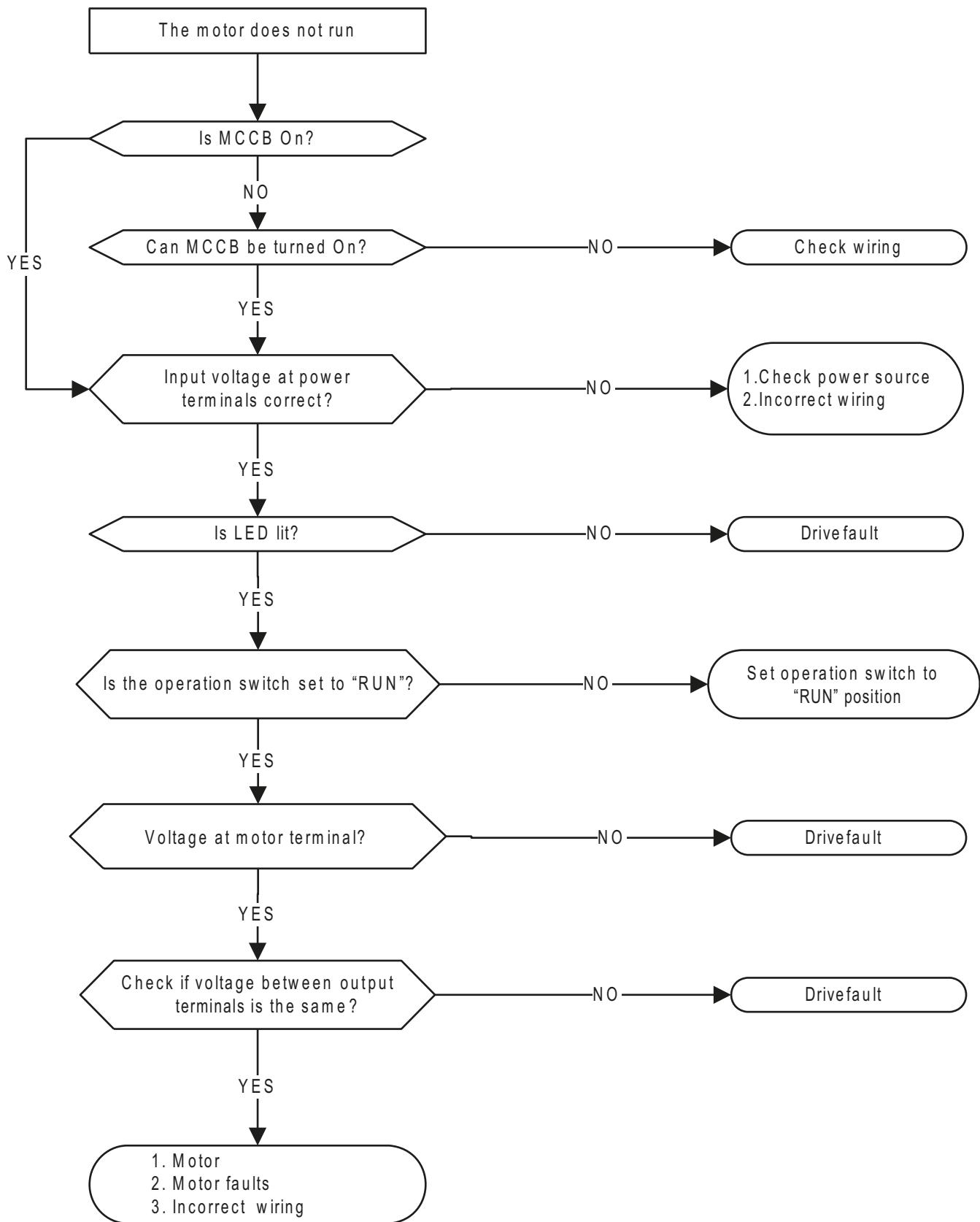




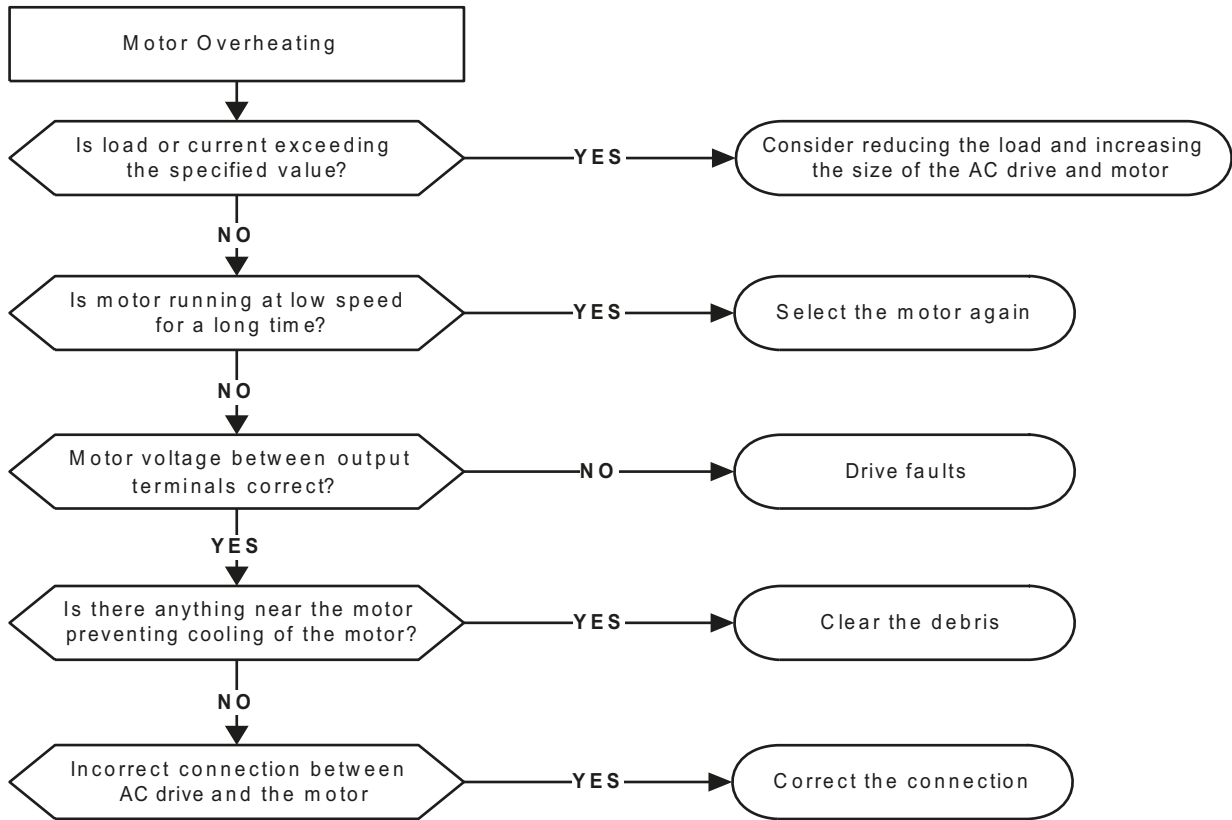
7.4.3 Overvoltage and Undervoltage Troubleshooting



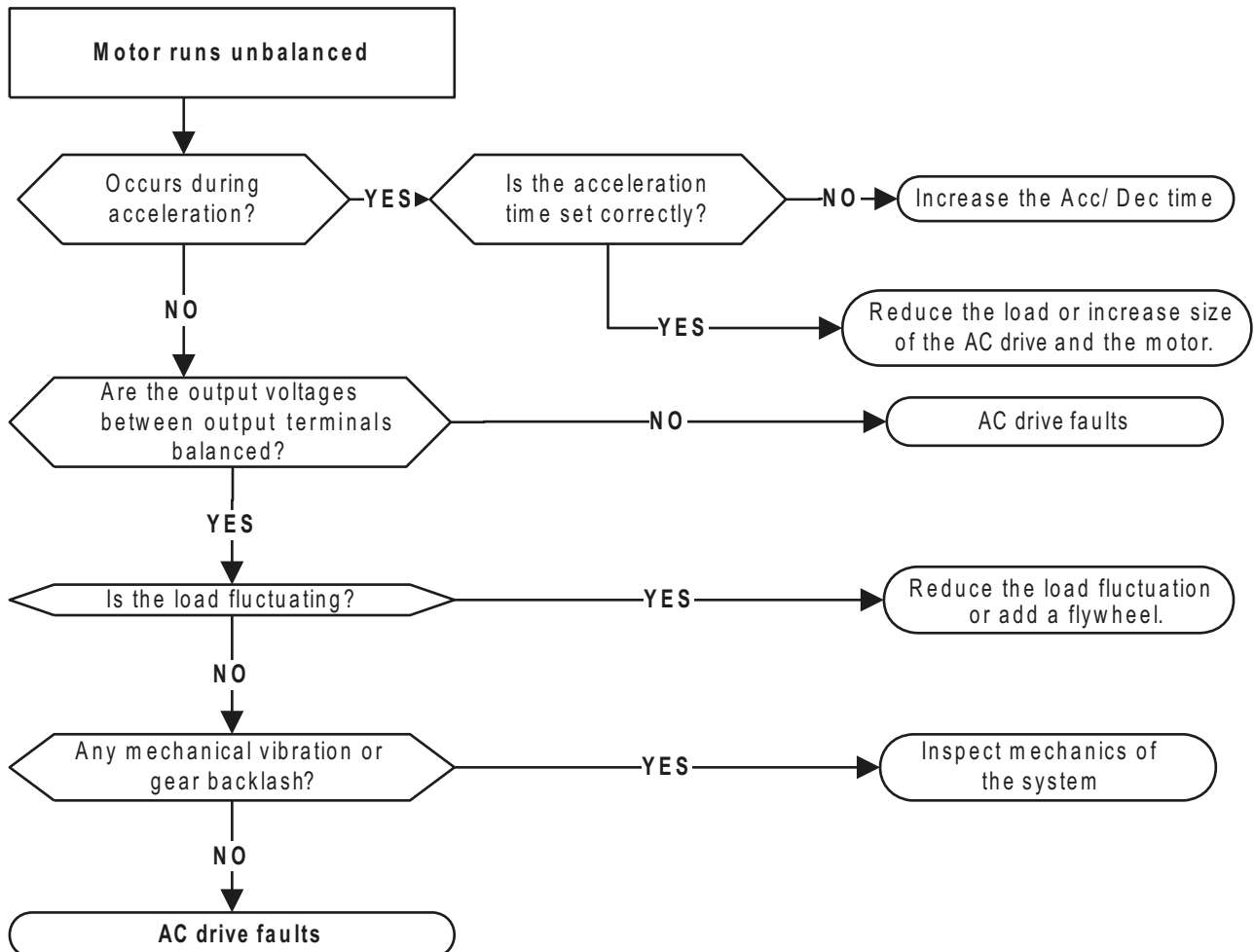
7.4.4 Motor not running



7.4.5 Motor overheating



7.4.6 Motor runs unbalanced



7.5 Routine and periodic inspection

To ensure safe and problem-free operation, check and maintain the AC Drive at regular intervals.

Use the checklist below as a maintenance guideline.

Disconnect power and wait approximately 10 minutes until to make sure no voltage is present on the output terminals before performing inspection or maintenance.

Items	Details	Checking Period		Methods	Criteria	Remedies
		Daily	1Year			
Environment and Ground Connection						
Ambient conditions on site	Confirm ambient temperature and relative humidity on site	☉		Measure with thermometer and hygrometer	Temp.: -10 to 40°C (14 to 120°F); Humidity: Below 95%RH	Improve the ambient conditions or relocate the drive to a better area.
	Are there flammable materials close to the AC Drive?	☉		Visual check	Keep area clear	
Installation Grounding	Any unusual vibration from surrounding machine?	☉		Visual and noise check	Keep area clear	Secure screws
	Is the grounding resistance correct?		☉	Measure the resistance with a multi-meter	240V class: < 100Ω 480V class: < 10Ω	Improve grounding if needed.
Terminals and Wiring						
Connection terminals	Check for loose terminals		☉	Visual check Check torque with screwdriver	Correct installation requirements	Secure terminals and remove rust or corrosion.
	Check for damage to the AC Drive		☉			
	Check for corroded Terminals		☉			
Wiring	Check for broken wires		☉	Visual check	Correct wiring requirements	Rectify as necessary
	Check wire insulation		☉			
Input Voltage						
Input power voltage	Check input voltage	☉		Measure the voltage with a multi-meter	Voltage must conform with specifications	Correct input voltage if necessary.

Items	Details	Checking Period		Methods	Criteria	Remedies
		Daily	1Year			
Circuit Boards and Components						
Printed circuit board	Check for damage to PCBs.		☉	Visual check	Correct component condition	Clean or replace the circuit board
	Check for discolored, overheated, or burned parts.		☉			
Capacitor	Check for unusual odor or leakage.	☉				
	Check for any physical damage or protrusion.		☉			
Power component	Check for any dust or debris.		☉	Measure with a multi-meter	No short circuit or faulty three-phase output	Clean components
	Check resistance between each terminal.		☉			Consult support
Peripheral Device						
Potentiometer	Is the potentiometer wiring or connector damaged?		☉	Visual check	No abnormalities	Replace potentiometer
Electromagnetic Contactor	Check contacts and connections for any abnormality.	☉				
	Unusual vibration and noise?	☉		Noise check		Replace Contactor
Reactor	Are there any abnormalities?	☉		Visual check		Replace Reactor
Cooling System						
Cooling fan	Unusual vibration and noise?		☉	Visual or sound check	Correct cooling	Consult support
	Excessive dust or debris?	☉		Visual check		Clean the fan
Heat sink	Excessive dust or debris?	☉				Clean debris or dust
Ventilation Path	Is the ventilation path blocked?	☉				Clean vents

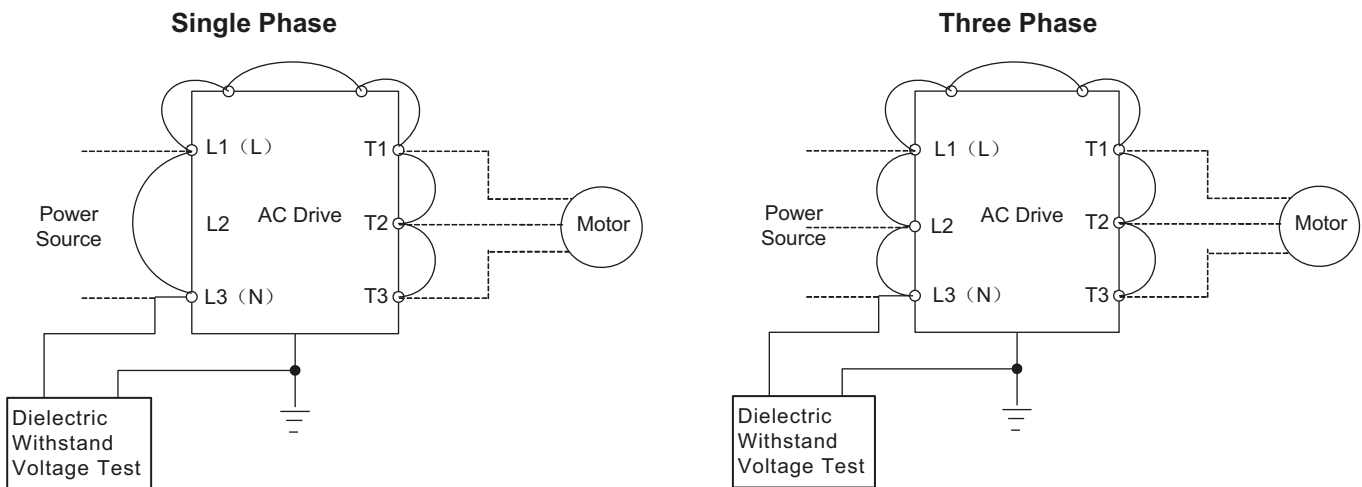
7.6 Maintenance

To ensure long-term reliability, follow the instructions below to perform regular inspection. Use the checklist below as a guideline for inspection. Turn the power off and wait for a minimum of 10 minutes before inspection to avoid potential shock hazard from the charge stored in capacitors.

Maintenance Check List

• Ensure that temperature and humidity where the AC Drive is installed falls within specifications. Make sure correct ventilation is provided.
• For replacement of a failed or damaged AC Drive consult support.
• Ensure that the installation area is free from dust and any other debris.
• Check and ensure that the ground connections are secure and correct.
• Terminal screws cannot be loose. Tighten terminals for power input and output of the AC Drive with power off.
• Do not perform any insulation testing on the control circuit.

Insulation Test (Megger Test)





DISCLAIMER

- Read all operating and safety instructions before installing, wiring, operating, servicing, or inspecting the AC Drive.
- Ensure that this manual is made available to the end user of the AC Drive.
- Store this manual in a safe, convenient location.
- The manual is subject to change without prior notice.

